

 **CHALLENGE**  [®]

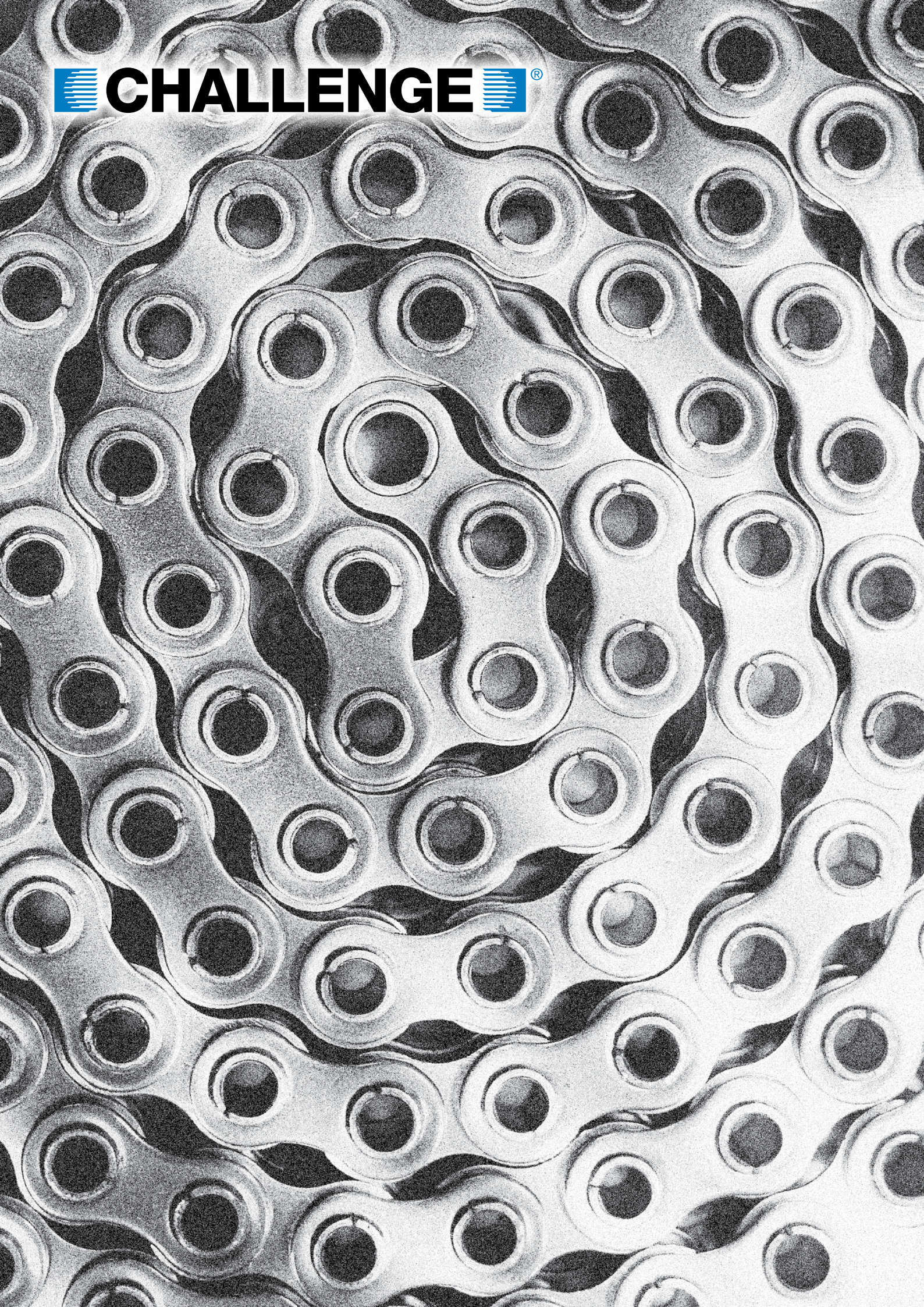

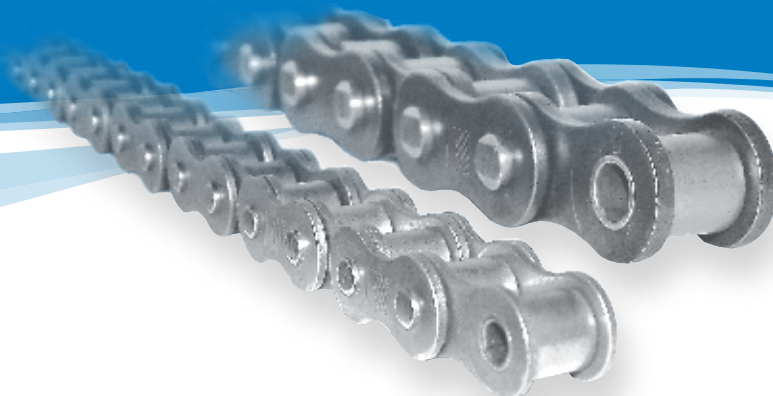

Features

Challenge offer a large range of various types of chain including – Transmission, Conveyor, Agricultural, Leaf and many types of special chains

Challenge Transmission Roller chain

Challenge roller chain is supplied in five metre boxes including one connecting link. Some sizes are available on reels or in 10ft boxes.

The range includes – ISO, BS, ANSI and many special types

ISO roller chain – standard, straight sided, extended pin, hollow pin, stainless steel, nickel plated, zinc plated, double pitch

ANSI roller chain – standard, heavy duty, cottered, cottered heavy duty, straight side plate, extended pin, stainless, nickel plated, zinc plated, double pitch (including extended pin, hollow pin and specials)

Roller chain attachments – cover a large range for both ISO and ANSI chain, Timber, Agricultural and Conveyor chain.

Challenge transmission chains have a longer life because:

- **Pins** – are manufactured from case hardened chrome manganese molybdenum steel. This increases wear resistance with more shock absorption ability
- **Pre-stretched** - pre-loading allow you to fit and forget the chain
- **Ball swaged holes** - combats fatigue failure
- **Shot peened rollers and side plates** - reduces fatigue failure
- **Deep wasted side plates** – increases breaking load and reduces stress
- **Solid rollers** – prolongs wear life
- **Bushes** – on sizes 32B – 64B are produced from seamless tube for reduced wear rate

X Series roller chain – Challenge offer an updated X series for sizes 24B-64B with spin riveted pins which provides all the good points as above, plus:-

- **Spin Riveted Case Hardened Pins in Alloy Steel** - providing optimum fit between the pin and side plate allowing for maximum life.
- **Seam orientated bushes** - on sizes 24B and 28B
- **Solid bushes from seamless tube** - on sizes from 32B to 64B

Challenge Conveyor chain

Meets Industry standards and is a quality, exceptional value for money chain

- **Material** - high quality alloy steels used throughout.
- **Case Hardened Alloy steel precision machined bushes** - ensuring minimum distortion and superior concentricity

- **Bushes have location shoulders** - for precise assembly, control on inner width and prevention of pin rotation. The bush is extended to form a clearance between the inner and outer plates to provide uniform lubrication, giving increased strength and life
- **Spin Riveted Case Hardened Pins in Alloy Steel** - for optimum life
- **Pins have location shoulders** - for precise positioning of outer plates which adds to the strength of the chain
- **Hardened Rollers with ground outside diameter** - gives excellent wear resistance and good load carrying qualities plus reduced wear on sprockets and a better visual result
- **Precision punched link plates** - gives high tolerance pitch control and maximum interference fit
- **Ball swaged holes** - combats fatigue
- **Links manufactured from high carbon steel** - giving increased breaking loads
- **Shot peened** - produces a strong surface and reduces fatigue
- **Attachment plates are jig assembled** - maintains position and squareness
- **Connecting links** - are available in rivet and lock nut (Nylok) construction

Attachments and Options:

Challenge offer welded and integral attachments, special bushes, bearings, zinc and nickel plated parts.

Molycoated pins, bushes and rollers. Plastic rollers, flanged rollers, hardened plates, stainless steel parts, liner bushes etc.

Specials are produced to the highest quality with a fast turnaround.

Challenge Leaf Chain

Applications:

Leaf chain is used in lifting applications such as Fork Lifts, Pneumatic and Hydraulic Jack fittings, etc. all of which move at slow speeds

Challenge offer Leaf Chain complying with ANSI standards in types BL (heavy duty), AL (light duty), EL and FLC

Where applicable, ISO equivalents are also given

Construction:

Link plates - are produced from carbon or alloy steel, especially selected to withstand sudden shock loads and as they are heat treated, maximum resistance to breakage is assured

Bearing pins - are produced from alloy steel having excellent resistance to bending due to the hardening treatment applied

Roller Chain

British Standard Roller Chain

BS228, ISO R606, DIN 8187

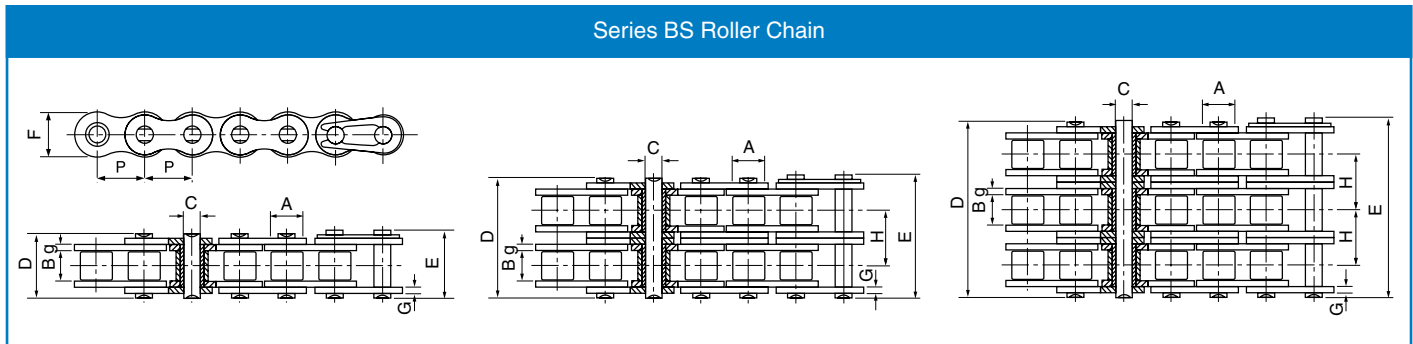

ISO Chain number	Pitch	Roller diameter	Width between inner plates	Pin diameter	Pin length		Inner plate height	Plate thickness	Transverse pitch	Minimum tensile strength	Average tensile strength	Weight
	P	A	B	C	D	E	F	g/G	H	kN	kN	kg/m
SIMPLEX												
04B-1	6.000	4.00	2.80	1.85	6.80	7.80	5.00	0.60	-	3.00	3.20	0.11
05B-1	8.000	5.00	3.00	2.31	8.20	8.90	7.10	0.80	-	5.00	5.90	0.20
*06B-1	9.525	6.35	5.72	3.28	13.15	14.10	8.20	1.30	-	9.00	10.40	0.41
08B-1	12.700	8.51	7.75	4.45	16.70	18.20	11.80	1.60	-	18.00	19.40	0.69
10B-1	15.875	10.16	9.65	5.08	19.50	20.90	14.70	1.70	-	22.40	27.50	0.93
12B-1	19.050	12.07	11.68	5.72	22.50	24.20	16.00	1.85	-	29.00	32.20	1.15
16B-1	25.400	15.88	17.02	8.28	36.10	37.40	21.00	4.15/3.1	-	60.00	72.80	2.71
20B-1	31.750	19.05	19.56	10.19	41.30	45.00	26.40	4.5/3.5	-	95.00	106.70	3.70
24B-1	38.100	25.40	25.40	14.63	53.40	57.80	33.20	6.0/4.8	-	160.00	178.00	7.10
28B-1	44.450	27.94	30.99	15.90	65.10	69.50	36.70	7.5/6.0	-	200.00	222.00	8.50
32B-1	50.800	29.21	30.99	17.81	66.00	71.00	42.00	7.0/6.0	-	250.00	277.50	10.25
40B-1	63.500	39.37	38.10	22.89	82.20	89.20	52.96	8.5/8.0	-	355.00	394.00	16.35
48B-1	76.200	48.26	45.72	29.24	99.10	107.00	63.80	12.0/10.0	-	560.00	621.60	25.00
56B-1	88.900	53.98	53.34	34.32	114.60	123.00	77.80	13.5/12.0	-	850.00	940.00	35.88
64B-1	101.600	63.50	60.96	39.40	130.00	138.50	90.17	15.0/13.0	-	1120.00	1240.00	46.50
DUPLEX												
05B-2	8.000	5.00	3.00	2.31	13.90	14.50	7.10	0.80	5.64	7.80	10.20	0.33
*06B-2	9.525	6.35	5.72	3.28	23.40	24.40	8.20	1.30	10.24	16.90	18.70	0.77
08B-2	12.700	8.51	7.75	4.45	31.20	32.20	11.80	1.60	13.92	32.00	38.70	1.34
10B-2	15.875	10.16	9.65	5.08	36.10	37.50	14.70	1.70	16.59	44.50	56.20	1.84
12B-2	19.050	12.07	11.68	5.72	42.00	43.60	16.00	1.85	19.46	57.80	66.10	2.31
16B-2	25.400	15.88	17.02	8.28	68.00	69.30	21.00	4.15/3.1	31.88	106.00	133.00	5.42
20B-2	31.750	19.05	19.56	10.19	77.80	81.50	26.40	4.5/3.5	36.45	170.00	211.20	7.20
24B-2	38.100	25.40	25.40	14.63	101.70	106.20	33.20	6.0/4.8	48.36	280.00	319.20	13.40
28B-2	44.450	27.94	30.99	15.90	124.60	129.10	36.70	7.5/6.0	59.56	360.00	406.80	16.60
32B-2	50.800	29.21	30.99	17.81	124.60	129.60	42.00	7.0/6.0	58.55	450.00	508.50	21.00
40B-2	63.500	39.37	38.10	22.89	154.50	161.50	52.96	8.5/8.0	72.29	630.00	711.90	32.00
48B-2	76.200	48.26	45.72	29.24	190.40	198.20	63.80	12.0/10.0	91.21	1000.00	1130.00	50.00
56B-2	88.900	53.98	53.34	34.32	221.20	229.60	77.80	13.5/12.0	106.60	1600.00	1760.00	71.76
64B-2	101.600	63.50	60.96	39.40	249.90	258.40	90.17	15.0/13.0	119.89	2000.00	2200.00	93.00
TRIPLEX												
05B-3	8.000	5.00	3.00	2.31	19.50	20.20	7.10	0.80	5.64	11.10	13.80	0.48
*06B-3	9.525	6.35	5.72	3.28	33.50	34.60	8.20	1.30	10.24	24.90	30.10	1.16
08B-3	12.700	8.51	7.75	4.45	45.10	46.10	11.80	1.60	13.92	47.50	57.80	2.03
10B-3	15.875	10.16	9.65	5.08	52.70	54.10	14.70	1.70	16.59	66.70	84.50	2.77
12B-3	19.050	12.07	11.68	5.72	61.50	63.10	16.00	1.85	19.46	86.70	101.80	3.46
16B-3	25.400	15.88	17.02	8.28	99.80	101.20	21.00	4.15/3.1	31.88	160.00	203.70	8.13
20B-3	31.750	19.05	19.56	10.19	114.20	117.90	26.40	4.5/3.5	36.45	250.00	290.00	10.82
24B-3	38.100	25.40	25.40	14.63	150.10	154.60	33.20	6.0/4.8	48.36	425.00	493.00	20.10
28B-3	44.450	27.94	30.99	15.90	184.20	188.70	36.70	7.5/6.0	59.56	530.00	609.50	24.92
32B-3	50.800	29.21	30.99	17.81	183.20	188.20	42.00	7.0/6.0	58.55	670.00	770.50	31.56
40B-3	63.500	39.37	38.10	22.89	226.80	233.80	52.96	8.5/8.0	72.29	950.00	1092.50	48.10
48B-3	76.200	48.26	45.72	29.24	281.60	289.40	63.80	12.0/10.0	91.21	1500.00	1710.00	75.00
56B-3	88.900	53.98	53.34	34.32	327.80	336.20	77.80	13.5/12.0	106.60	2240.00	2240.00	107.64
64B-3	101.600	63.50	60.96	39.40	369.80	378.30	90.17	15.0/13.0	119.89	3000.00	3300.00	139.50

Sizes 24B through to 64B are available with standard and spin riveted pins.

* Straight Side Plate Chain
Standard boxed lengths are 5 metres Special lengths available

All dimensions in millimetres unless otherwise stated. Every effort has been taken to ensure that the data listed in this catalogue is correct. Challenge accepts no liability for any inaccuracies or damage caused.

Roller Chain

ANSI Standard Roller Chain

ANSI B29.1, ISO R606, DIN 8188

Series ANSI Roller Chain

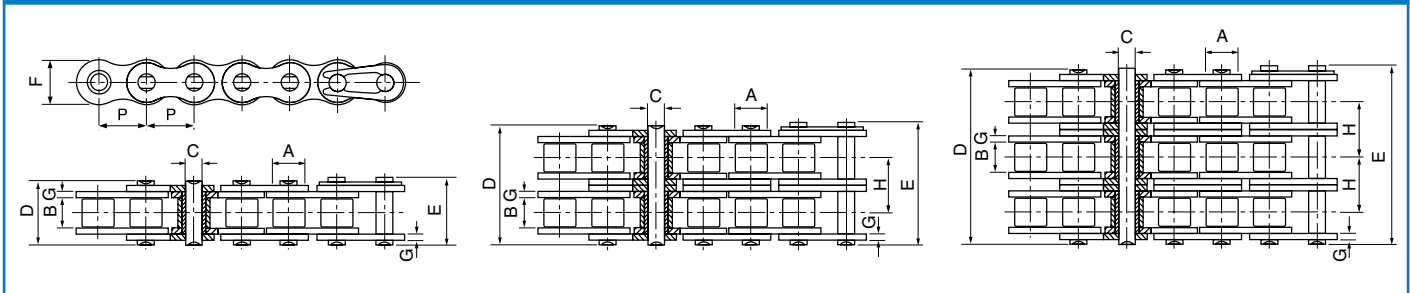

ISO Chain number	Pitch	Roller diameter	Width between inner plates	Pin diameter	Pin length		Inner plate height	Plate thickness	Transverse pitch	Minimum tensile strength	Average tensile strength	Weight
	P	A	B	C	D	E	F	g/G	H	kN	kN	kg/m
SIMPLEX												
*15-1	4.763	2.48	2.38	1.62	6.10	6.90	4.30	0.60	-	1.8	2.0	0.08
*25-1	6.350	3.30	3.18	2.31	7.90	8.40	6.00	0.80	-	3.5	4.6	0.15
*35-1	9.525	5.08	4.77	3.58	12.40	13.17	9.00	1.30	-	7.9	10.8	0.33
41-1	12.700	7.77	6.25	3.58	13.75	15.00	9.91	1.30	-	6.7	12.6	0.41
40-1	12.700	7.95	7.85	3.96	16.60	17.80	12.00	1.50	-	14.1	17.5	0.62
50-1	15.875	10.16	9.40	5.08	20.70	22.20	15.09	2.03	-	22.2	29.4	1.02
60-1	19.050	11.91	12.57	5.94	25.90	27.70	18.00	2.42	-	31.8	41.5	1.50
80-1	25.400	15.88	15.75	7.92	32.70	35.00	24.00	3.25	-	56.7	69.4	2.60
100-1	31.750	19.05	18.90	9.53	40.40	44.70	30.00	4.00	-	88.5	109.2	3.91
120-1	38.100	22.23	25.22	11.10	50.30	54.30	35.70	4.80	-	127.0	156.3	5.62
140-1	44.450	25.40	25.22	12.70	54.40	59.00	41.00	5.60	-	172.4	212.0	7.50
160-1	50.800	28.58	31.55	14.27	64.80	69.60	47.80	6.40	-	226.8	278.9	10.10
180-1	57.150	35.71	35.48	17.46	72.80	78.60	53.60	7.20	-	280.2	341.8	13.45
200-1	63.500	39.68	37.85	19.85	80.30	87.20	60.00	8.00	-	353.8	431.6	16.15
240-1	76.200	47.63	47.35	23.81	95.50	103.00	72.39	9.50	-	510.3	622.5	23.20
DUPLEX												
*25-2	6.350	3.30	3.18	2.31	14.50	15.00	6.00	0.80	6.40	7.0	8.6	0.28
*35-2	9.525	5.08	4.77	3.58	22.50	23.30	9.00	1.30	10.13	15.8	19.7	0.63
41-2	12.700	7.77	6.25	3.58	25.70	26.90	9.91	1.30	11.95	13.3	16.9	0.81
40-2	12.700	7.95	7.85	3.96	31.00	32.20	12.00	1.50	14.38	28.2	35.9	1.12
50-2	15.875	10.16	9.40	5.08	38.90	40.40	15.09	2.03	18.11	44.4	58.1	2.00
60-2	19.050	11.91	12.57	5.94	48.80	50.50	18.00	2.42	22.78	63.6	82.1	2.92
80-2	25.400	15.88	15.75	7.92	62.70	64.30	24.00	3.25	29.29	113.4	141.8	5.15
100-2	31.750	19.05	18.90	9.53	76.40	80.50	30.00	4.00	35.76	177.0	219.4	7.80
120-2	38.100	22.23	25.22	11.10	95.80	99.70	35.70	4.80	45.44	254.0	314.9	11.70
140-2	44.450	25.40	25.22	12.70	103.30	107.90	41.00	5.60	48.87	344.8	427.5	15.14
160-2	50.800	28.58	31.55	14.27	123.30	128.10	47.80	6.40	58.55	453.6	562.4	20.14
180-2	57.150	35.71	35.48	17.46	138.60	144.40	53.60	7.20	65.84	560.5	695.0	29.22
200-2	63.500	39.68	37.85	19.85	151.90	158.80	60.00	8.00	71.55	707.6	877.4	32.24
240-2	76.200	47.63	47.35	23.81	183.40	190.80	72.39	9.50	87.83	1020.6	1255.3	45.23
TRIPLEX												
*25-3	6.350	3.30	3.18	2.31	21.00	21.50	6.00	0.80	6.40	10.5	12.6	0.44
*35-3	9.525	5.08	4.77	3.58	32.70	33.50	9.00	1.30	10.13	23.7	28.6	1.05
40-3	12.700	7.95	7.85	3.96	45.40	46.60	12.00	1.50	14.38	42.3	50.0	1.90
50-3	15.875	10.16	9.40	5.08	57.00	58.50	15.09	2.03	18.11	66.6	77.8	3.09
60-3	19.050	11.91	12.57	5.94	71.50	73.30	18.00	2.42	22.78	95.4	111.1	4.54
80-3	25.400	15.88	15.75	7.92	91.70	93.60	24.00	3.25	29.29	170.1	198.4	7.89
100-3	31.750	19.05	18.90	9.53	112.20	116.30	30.00	4.00	35.76	265.5	309.6	11.77
120-3	38.100	22.23	25.22	11.10	141.40	145.20	35.70	4.80	45.44	381.0	437.2	17.53
140-3	44.450	25.40	25.22	12.70	152.20	156.80	41.00	5.60	48.87	517.2	593.3	22.20
160-3	50.800	28.58	31.55	14.27	181.80	186.60	47.80	6.40	58.55	680.4	780.6	30.02
180-3	57.150	35.71	35.48	17.46	204.40	210.20	53.60	7.20	65.84	840.7	983.6	38.22
200-3	63.500	39.68	37.85	19.85	223.50	230.40	60.00	8.00	71.55	1061.4	1217.8	49.03
240-3	76.200	47.63	47.35	23.81	271.30	278.60	72.39	9.50	87.83	1530.9	1756.5	71.60

* Bush chain: **A** in the table indicates the external diameter of the bush Standard boxed lengths are 5 metres. Special lengths available.

Every effort has been taken to ensure that the data listed in this catalogue is correct. Challenge accepts no liability for any inaccuracies or damage caused. All dimensions in millimetres unless otherwise stated.

Roller Chain

ANSI Heavy Duty Roller Chain

ANSI B29.1, ISO R606, DIN 8188

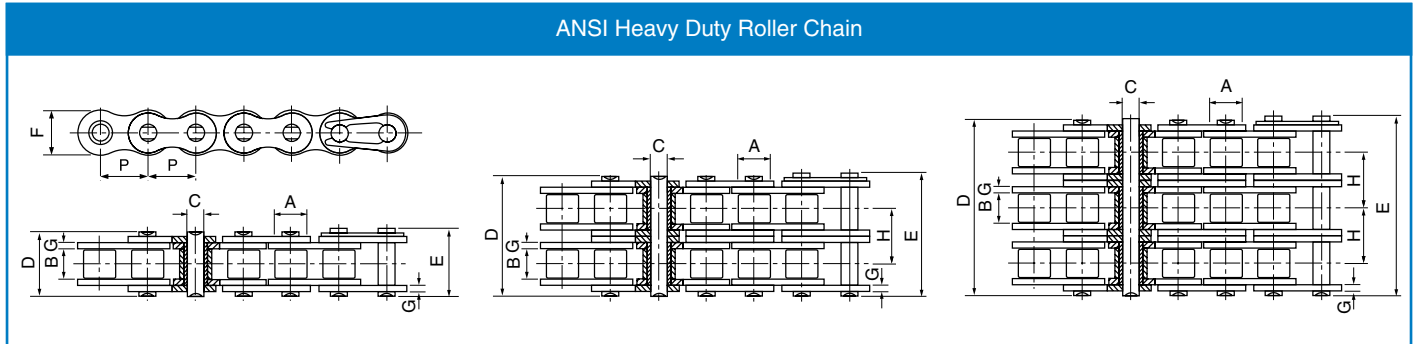

ANSI Chain number	Pitch	Roller diameter	Width between inner plates	Pin diameter	Pin length		Inner plate height	Plate thickness	Transverse pitch	Minimum tensile strength	Average tensile strength	Weight
	P	A	B	C	D	E	F	G	H	kN	kN	kg/m
SIMPLEX												
40H-1	12.700	7.95	7.85	3.96	18.80	19.90	12.00	2.03	-	14.10	19.10	0.82
50H-1	15.875	10.16	9.40	5.08	22.10	23.40	15.09	2.42	-	22.20	30.20	1.25
60H-1	19.050	11.91	12.57	5.94	29.20	31.00	18.00	3.25	-	31.80	42.70	1.87
80H-1	25.400	15.88	15.75	7.92	36.20	37.70	24.00	4.00	-	56.70	71.40	3.10
100H-1	31.750	19.05	18.90	9.53	43.60	46.90	30.00	4.80	-	88.50	112.40	4.52
120H-1	38.100	22.23	25.22	11.10	53.50	57.50	35.70	5.60	-	127.00	160.90	6.60
140H-1	44.450	25.40	25.22	12.70	57.60	62.20	41.00	6.40	-	172.40	217.30	8.30
160H-1	50.800	28.58	31.55	14.27	68.20	73.00	47.80	7.20	-	226.80	285.80	10.30
200H-1	63.500	39.68	37.85	19.85	86.60	93.50	60.00	9.50	-	353.80	444.50	19.16
DUPLEX												
60H-2	19.050	11.91	12.57	5.94	55.30	57.10	18.00	3.25	26.11	63.60	84.50	3.71
80H-2	25.400	15.88	15.75	7.92	68.80	70.30	24.00	4.00	32.59	113.40	145.30	6.15
100H-2	31.750	19.05	18.90	9.53	82.70	86.00	30.00	4.80	39.09	177.00	225.90	9.03
120H-2	38.100	22.23	25.22	11.10	102.40	106.40	35.70	5.60	48.87	254.00	322.70	13.13
140H-2	44.450	25.40	25.22	12.70	109.80	114.40	41.00	6.40	52.20	344.80	437.70	16.60
160H-2	50.800	28.58	31.55	14.27	130.10	134.90	47.80	7.20	61.90	453.60	571.60	20.20
200H-2	63.500	39.68	37.85	19.85	164.90	171.80	60.00	9.50	78.31	707.60	894.90	38.11
TRIPLEX												
60H-3	19.050	11.91	12.57	5.94	81.40	83.20	18.00	3.25	26.11	95.40	113.90	5.54
80H-3	25.400	15.88	15.75	7.92	101.40	102.90	24.00	4.00	32.59	170.10	203.50	9.42
100H-3	31.750	19.05	18.90	9.53	121.80	125.10	30.00	4.80	39.09	265.50	314.80	12.96
120H-3	38.100	22.23	25.22	11.10	151.20	155.20	35.70	5.60	48.87	381.00	444.70	19.64
140H-3	44.450	25.40	25.22	12.70	162.00	166.60	41.00	6.40	52.20	517.20	598.40	24.90
160H-3	50.800	28.58	31.55	14.27	192.00	196.80	47.80	7.20	61.90	680.40	787.30	30.10
200H-3	63.500	39.68	37.85	19.85	243.20	250.10	60.00	9.50	78.31	1061.40	1228.20	57.06

Standard boxed lengths are 5 metres
Special lengths available.

All dimensions in millimetres unless otherwise stated. Every effort has been taken to ensure that the data listed in this catalogue is correct. Challenge accepts no liability for any inaccuracies or damage caused.

Roller Chain

ANSI Cotted Series Roller Chain

ANSI B29.1, ISO R606, DIN 8188

ANSI Cotted A Series Roller Chain

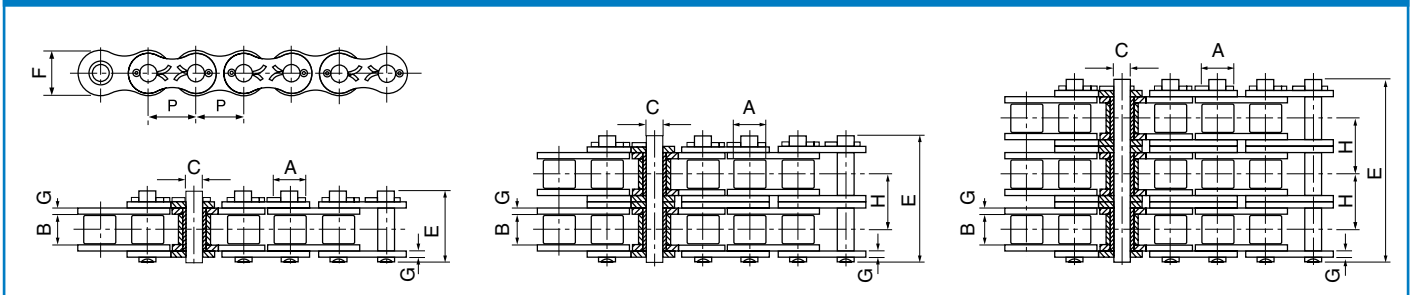

ANSI Chain number	Pitch	Roller diameter	Width between inner plates	Pin diameter	Pin length	Inner plate height	Plate thickness	Transverse pitch	Minimum tensile strength	Average tensile strength	Weight
	P	A	B	C	E	F	G	H	kN	kN	kg/m
SIMPLEX											
50-1	15.875	10.16	9.40	5.08	23.00	15.09	2.03	-	22.20	29.40	1.02
60-1	19.050	11.91	12.57	5.94	28.30	18.00	2.42	-	31.80	41.50	1.50
80-1	25.400	15.88	15.75	7.92	36.50	24.00	3.25	-	56.70	69.40	2.60
100-1	31.750	19.05	18.90	9.53	44.70	30.00	4.00	-	88.50	109.20	3.91
120-1	38.100	22.23	25.22	11.10	54.30	35.70	4.80	-	127.00	156.30	5.62
140-1	44.450	25.40	25.22	12.70	59.00	41.00	5.60	-	172.40	212.00	7.50
160-1	50.800	28.58	31.55	14.27	69.60	47.80	6.40	-	226.80	278.90	10.10
180-1	57.150	35.71	35.48	17.46	78.60	53.60	7.20	-	280.20	341.80	13.45
200-1	63.500	39.68	37.85	19.85	87.20	60.00	8.00	-	353.80	431.60	16.15
240-1	76.200	47.63	47.35	23.81	103.00	72.39	9.50	-	510.30	622.50	23.20
DUPLEX											
50-2	15.875	10.16	9.40	5.08	41.20	15.09	2.03	18.11	44.40	58.10	2.00
60-2	19.050	11.91	12.57	5.94	51.10	18.00	2.42	22.78	63.60	82.10	2.92
80-2	25.400	15.88	15.75	7.92	65.80	24.00	3.25	29.29	113.40	141.80	5.15
100-2	31.750	19.05	18.90	9.53	80.50	30.00	4.00	35.76	177.00	219.40	7.80
120-2	38.100	22.23	25.22	11.10	99.70	35.70	4.80	45.44	254.00	314.90	11.70
140-2	44.450	25.40	25.22	12.70	107.90	41.00	5.60	48.87	344.80	427.50	15.14
160-2	50.800	28.58	31.55	14.27	128.10	47.80	6.40	58.55	453.60	562.40	20.14
180-2	57.150	35.71	35.48	17.46	144.40	53.60	7.20	65.84	560.50	695.00	29.22
200-2	63.500	39.68	37.85	19.85	158.80	60.00	8.00	71.55	707.60	877.40	32.24
240-2	76.200	47.63	47.35	23.81	190.80	72.39	9.50	87.83	1020.60	1255.30	45.23
TRIPLEX											
50-3	15.875	10.16	9.40	5.08	59.30	15.09	2.03	18.11	66.60	77.80	3.09
60-3	19.050	11.91	12.57	5.94	73.90	18.00	2.42	22.78	95.40	111.10	4.54
80-3	25.400	15.88	15.75	7.92	93.60	24.00	3.25	29.29	170.10	198.40	7.89
100-3	31.750	19.05	18.90	9.53	116.30	30.00	4.00	35.76	265.50	309.60	11.77
120-3	38.100	22.23	25.22	11.10	145.20	35.70	4.80	45.44	381.00	437.20	17.53
140-3	44.450	25.40	25.22	12.70	156.80	41.00	5.60	48.87	517.20	593.30	22.20
160-3	50.800	28.58	31.55	14.27	186.60	47.80	6.40	58.55	680.40	780.60	30.02
180-3	57.150	35.71	35.48	17.46	210.20	53.60	7.20	65.84	840.70	983.60	38.22
200-3	63.500	39.68	37.85	19.85	230.40	60.00	8.00	71.55	1061.40	1217.80	49.03
240-3	76.200	47.63	47.35	23.81	278.60	72.39	9.50	87.83	1530.90	1756.50	71.60

Standard boxed lengths are 5 metres
Special lengths available.

Roller Chain

ANSI Cottered Heavy Duty Roller Chain

ANSI B29.1, ISO R606, DIN 8188

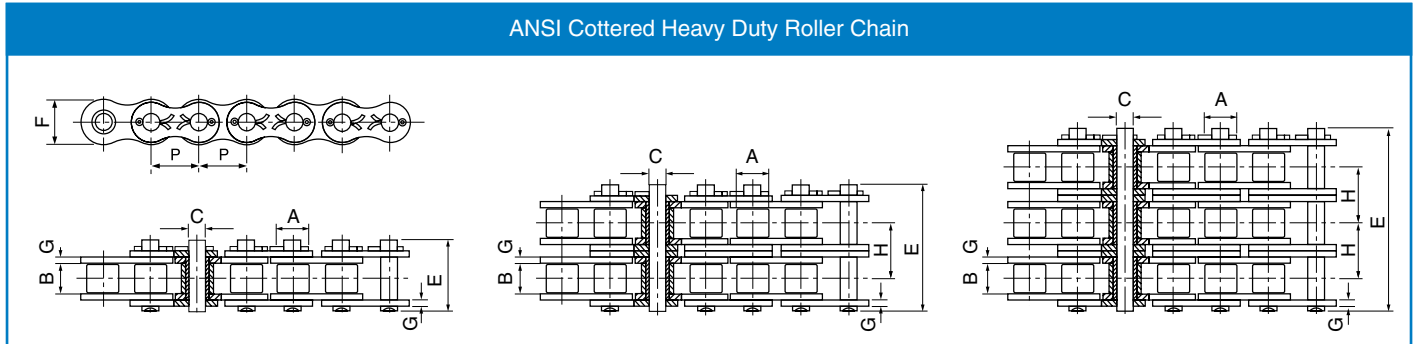

ANSI Chain number	Pitch P	Roller diameter A	Width between inner plates B	Pin diameter C	Pin length E	Inner plate height F	Plate thickness G	Transverse pitch H	Minimum tensile strength kN	Average tensile strength kN	Weight kg/m
SIMPLEX											
50H-1	15.875	10.16	9.40	5.08	24.40	15.09	2.42	-	22.20	30.20	1.25
60H-1	19.050	11.91	12.57	5.94	31.60	18.00	3.25	-	31.80	42.70	1.87
80H-1	25.400	15.88	15.75	7.92	39.40	24.00	4.00	-	56.70	71.40	3.10
100H-1	31.750	19.05	18.90	9.53	46.90	30.00	4.80	-	88.50	112.40	4.52
120H-1	38.100	22.23	25.22	11.10	57.50	35.70	5.60	-	127.00	160.90	6.60
140H-1	44.450	25.40	25.22	12.70	62.20	41.00	6.40	-	172.40	217.30	8.30
160H-1	50.800	28.58	31.55	14.27	73.00	47.80	7.20	-	226.80	285.80	10.30
200H-1	63.500	39.68	37.85	19.85	93.50	60.00	9.50	-	353.80	444.50	19.16
DUPLEX											
60H-2	19.050	11.91	12.57	5.94	57.70	18.00	3.25	26.11	63.60	84.50	3.71
80H-2	25.400	15.88	15.75	7.92	72.00	24.00	4.00	32.59	113.40	145.30	6.15
100H-2	31.750	19.05	18.90	9.53	86.00	30.00	4.80	39.09	177.00	225.90	9.03
120H-2	38.100	22.23	25.22	11.10	106.40	35.70	5.60	48.87	254.00	322.70	13.13
140H-2	44.450	25.40	25.22	12.70	114.40	41.00	6.40	52.20	344.80	437.70	16.60
160H-2	50.800	28.58	31.55	14.27	134.90	47.80	7.20	61.90	453.60	571.60	20.20
200H-2	63.500	39.68	37.85	19.85	171.80	60.00	9.50	78.31	707.60	894.90	31.11
TRIPLEX											
60H-3	19.050	11.91	12.57	5.94	83.80	18.00	3.25	26.11	95.40	113.90	5.54
80H-3	25.400	15.88	15.75	7.92	104.60	24.00	4.00	32.59	170.10	203.50	9.42
100H-3	31.750	19.05	18.90	9.53	125.10	30.00	4.80	39.09	265.50	314.80	12.96
120H-3	38.100	22.23	25.22	11.10	155.20	35.70	5.60	48.87	381.00	444.70	19.64
140H-3	44.450	25.40	25.22	12.70	166.60	41.00	6.40	52.20	517.20	598.40	24.90
160H-3	50.800	28.58	31.55	14.27	196.80	47.80	7.20	61.90	680.40	787.30	30.10
200H-3	63.500	39.68	37.85	19.85	250.10	60.00	9.50	78.31	1061.40	1228.20	57.06

Standard boxed lengths are 5 metres
Special lengths available.

Chain Breakers

Model	Range	
	From inch	To inch
CB-101 (Small)	3/8"	3/4"
CB-102 (Large)	3/4"	1.1/4"

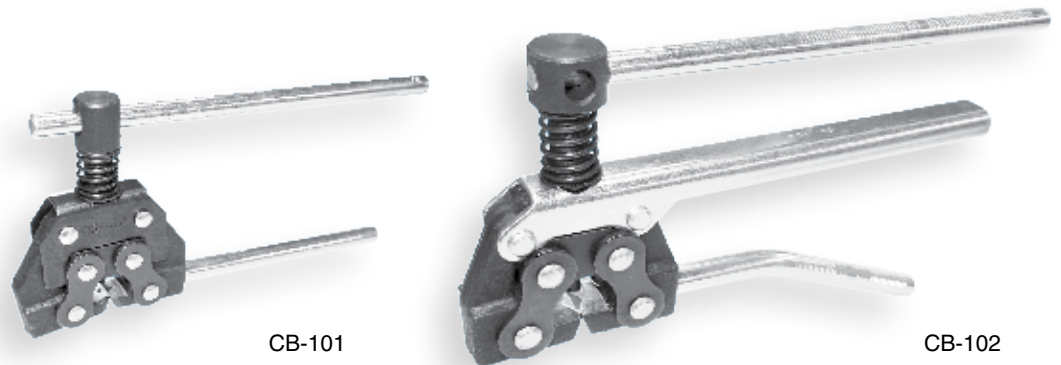

All dimensions in millimetres unless otherwise stated. Every effort has been taken to ensure that the data listed in this catalogue is correct. Challenge accepts no liability for any inaccuracies or damage caused.

Roller Chain

ANSI Straight Side Plate Roller Chain

ANSI B29.1, ISO R606, DIN 8188

ANSI Straight Side Plate Roller Chain

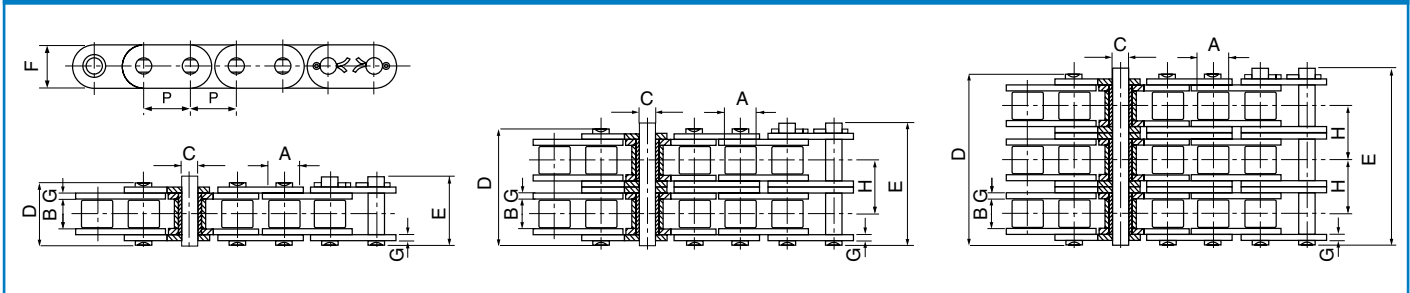

ANSI Chain number	Pitch	Roller diameter	Width between inner plates	Pin diameter	Pin length		Inner plate height	Plate thickness	Transverse pitch	Minimum tensile strength	Average tensile strength	Weight
	P	A	B	C	D	E	F	G	H	kN	kN	kg/m
SIMPLEX												
C40-1	12.700	7.95	7.85	3.96	16.60	18.80	12.00	1.50	-	14.10	17.50	0.73
C50-1	15.875	10.16	9.40	5.08	20.70	23.30	15.09	2.03	-	22.20	29.40	1.23
C60-1	19.050	11.91	12.57	5.94	25.90	28.30	18.0/18.2	2.42	-	31.80	41.50	1.81/1.83
C80-1	25.400	15.88	15.75	7.92	32.70	36.50	24.00	3.25	-	56.70	69.40	3.09
C100-1	31.750	19.05	18.90	9.53	40.40	44.70	30.00	4.00	-	88.50	109.20	4.56
C120-1	38.100	22.23	25.22	11.10	50.30	54.30	35.70	4.80	-	127.00	156.30	6.86
C140-1	44.450	25.40	25.22	12.70	54.40	59.00	41.00	5.60	-	172.40	212.00	8.49
C160-1	50.800	28.58	31.55	14.27	64.80	69.60	47.80	6.40	-	226.80	278.90	11.50
DUPLEX												
C40-2	12.700	7.95	7.85	3.96	31.00	33.20	12.00	1.50	14.38	28.20	35.90	1.43
C50-2	15.875	10.16	9.40	5.08	38.90	41.40	15.09	2.03	18.11	44.40	58.10	2.42
C60-2	19.050	11.91	12.57	5.94	48.80	51.10	18.0/18.2	2.42	22.78	63.60	82.10	3.58/3.62
C80-2	25.400	15.88	15.75	7.92	62.70	65.80	24.00	3.25	29.29	113.40	141.80	6.12
C100-2	31.750	19.05	18.90	9.53	76.40	80.50	30.00	4.00	35.76	177.00	219.40	9.08
C120-2	38.100	22.23	25.22	11.10	95.80	99.70	35.70	4.80	45.44	254.00	314.90	13.60
C140-2	44.450	25.40	25.22	12.70	103.30	107.90	41.00	5.60	48.87	344.80	427.50	16.86
C160-2	50.800	28.58	31.55	14.27	123.30	128.10	47.80	6.40	58.55	453.60	562.40	22.90
TRIPLEX												
C40-3	12.700	7.95	7.85	3.96	45.40	47.60	12.00	1.50	14.38	42.30	50.00	2.14
C50-3	15.875	10.16	9.40	5.08	57.00	59.50	15.09	2.03	18.11	66.60	77.80	3.62
C60-3	19.050	11.91	12.57	5.94	71.50	73.90	18.0/18.2	2.42	22.78	95.40	111.10	5.36/5.41
C80-3	25.400	15.88	15.75	7.92	91.70	95.10	24.00	3.25	29.29	170.10	198.40	9.10
C100-3	31.750	19.05	18.90	9.53	112.20	116.30	30.00	4.00	35.76	265.50	309.60	13.60
C120-3	38.100	22.23	25.22	11.10	141.40	145.20	35.70	4.80	45.44	381.00	437.20	20.43
C140-3	44.450	25.40	25.22	12.70	152.20	156.80	41.00	5.60	48.87	517.20	593.30	25.23
C160-3	50.800	28.58	31.55	14.27	181.80	186.60	47.80	6.40	58.55	680.40	780.60	34.19

Standard boxed lengths are 5 metres
Special lengths available.

Chain Pullers

Model	Range	
	From inch	To inch
CB-105 (Small)	1/4"	3/4"
CB-106 (Large)	3/4"	1.1/4"

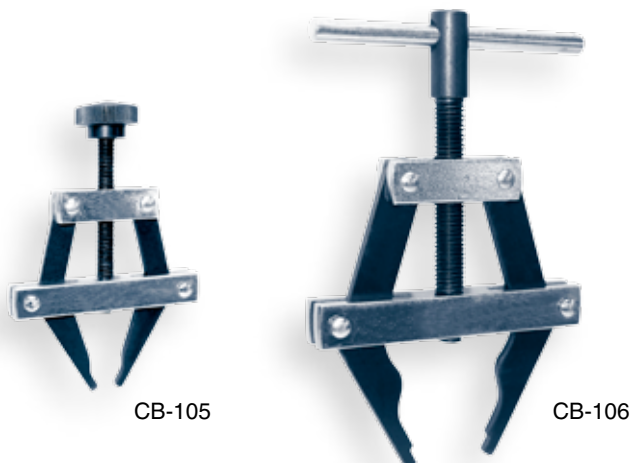

Roller Chain

BS Straight Side Plate Roller Chain

ANSI B29.1, ISO R606, DIN 8187

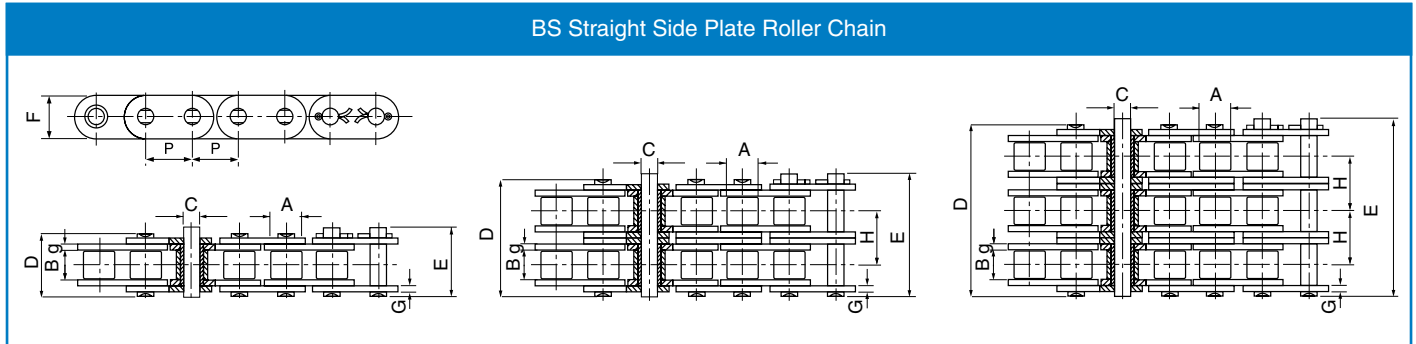

ISO Chain number	Pitch	Roller diameter	Width between inner plates	Pin diameter	Pin length		Inner plate height	Plate thickness g/G	Transverse pitch	Minimum tensile strength kN	Average tensile strength kN	Weight kg/m
	P	A	B	C	D	E						
SIMPLEX												
08B-1 GL	12.700	8.51	7.75	4.45	16.70	18.20	11.80	1.60	-	18.00	19.50	0.80
10B-1 GL	15.875	10.16	9.65	5.08	19.50	20.90	14.70	1.70	-	22.40	27.90	1.06
12B-1 GL	19.050	12.07	11.68	5.72	22.50	25.20	16.00	1.85	-	29.00	32.20	1.32
16B-1 GL	25.400	15.88	17.02	8.28	36.10	39.10	21.0/24.0	4.15/3.1	-	60.00	72.80	3.08/3.49
20B-1 GL	31.750	19.05	19.56	10.19	41.30	45.00	26.40	4.5/3.5	-	95.00	106.70	4.16
24B-1 GL	38.100	25.40	25.40	14.63	53.40	57.80	33.20	6.0/4.8	-	160.00	178.00	7.47
28B-1 GL	44.450	27.94	30.99	15.90	65.10	69.50	36.70	7.5/6.0	-	200.00	222.00	9.90
32B-1 GL	50.800	29.21	30.99	17.81	66.00	71.00	42.00	7.0/6.0	-	250.00	277.50	10.45
DUPLEX												
08B-2 GL	12.700	8.51	7.75	4.45	31.20	32.20	11.80	1.60	13.92	32.00	38.70	1.45
10B-2 GL	15.875	10.16	9.65	5.08	36.10	37.50	14.70	1.70	16.59	44.50	57.80	2.00
12B-2 GL	19.050	12.07	11.68	5.72	42.00	44.70	16.00	1.85	19.46	57.80	66.10	2.62
16B-2 GL	25.400	15.88	17.02	8.28	68.00	71.00	21.0/24.0	4.15/3.1	31.88	106.00	133.00	6.10/6.92
20B-2 GL	31.750	19.05	19.56	10.19	77.80	81.50	26.40	4.5/3.5	36.45	170.00	211.20	8.23
24B-2 GL	38.100	25.40	25.40	14.63	101.70	106.20	33.20	6.0/4.8	48.36	280.00	319.20	14.77
28B-2 GL	44.450	27.94	30.99	15.90	124.60	129.10	36.70	7.5/6.0	59.56	360.00	406.80	19.82
32B-2 GL	50.800	29.21	30.99	17.81	124.60	129.60	42.00	7.0/6.0	58.55	450.00	508.50	20.94
TRIPLEX												
08B-3 GL	12.700	8.51	7.75	4.45	45.10	46.10	11.80	1.60	13.92	47.50	57.80	2.10
10B-3 GL	15.875	10.16	9.65	5.08	52.70	54.10	14.70	1.70	16.59	66.70	84.50	2.87
12B-3 GL	19.050	12.07	11.68	5.72	61.50	64.20	16.00	1.85	19.46	86.70	101.80	3.89
16B-3 GL	25.400	15.88	17.02	8.28	99.80	102.90	21.0/24.0	4.15/3.1	31.88	160.00	203.70	9.12/10.34
20B-3 GL	31.750	19.05	19.56	10.19	114.20	117.90	26.40	4.5/3.5	36.45	250.00	290.00	11.34
24B-3 GL	38.100	25.40	25.40	14.63	150.10	154.60	33.20	6.0/4.8	48.36	425.00	493.00	22.10
28B-3 GL	44.450	27.94	30.99	15.90	184.20	188.70	36.70	7.5/6.0	59.56	530.00	609.50	29.64
32B-3 GL	50.800	29.21	30.99	17.81	183.20	188.20	42.00	7.0/6.0	58.55	670.00	770.50	31.27

Standard boxed lengths are 5 metres
Special lengths available.

All dimensions in millimetres unless otherwise stated. Every effort has been taken to ensure that the data listed in this catalogue is correct. Challenge accepts no liability for any inaccuracies or damage caused.

Roller Chain

Special Transmission Roller Chain

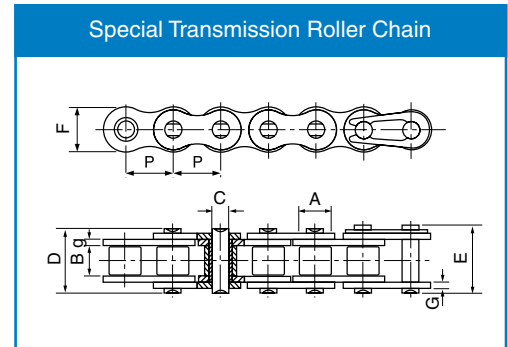

ISO Chain number	Pitch	Roller diameter	Width between inner plates	Pin diameter	Pin length		Inner plate height F	Plate thickness g/G	Minimum tensile strength kN	Average tensile strength kN	Weight kg/m
	P	A	B	C	D	E					
04BH	6.00	4.00	2.80	1.85	8.40	9.40	5.00	0.90	5.00	5.30	0.14
081	12.70	7.75	3.30	3.66	9.30	12.30	9.90	1.00	8.00	9.40	0.28
084	12.70	7.75	4.88	4.09	14.60	17.60	11.50	1.80	15.60	15.70	0.51
415	12.70	7.77	4.76	3.60	11.00	12.40	9.70	1.00	6.86	7.60	0.32
415H	12.70	7.77	4.76	3.96	13.10	14.50	12.00	1.50	14.40	16.10	0.55
415B/083	12.70	7.75	4.88	4.09	12.90	14.40	10.30	1.30	12.00	14.20	0.44
415BF1	12.70	7.75	4.88	4.09	11.50	13.00	10.30	1.00	9.00	10.60	0.38
423	12.70	8.51	6.40	4.45	15.60	17.10	12.40	1.70	19.60	21.90	0.71
478	12.70	7.80	4.80	4.00	11.60	13.65	10.46	1.25	9.80	12.80	0.39
08BF	12.70	8.51	5.55	4.45	14.60	16.10	11.80	1.60	17.80	19.20	0.66
12BH	19.05	12.07	11.68	5.94	25.20	26.80	16.00	2.42	40.00	44.40	1.45
12BHF1	19.05	12.07	11.68	6.10	25.00	27.20	16.50	2.50	44.00	48.80	1.46
16BF1	25.40	15.88	12.20	8.28	31.40	32.70	21.00	4.15/3.1	60.00	71.40	2.60
16BF2	25.40	15.88	17.02	8.28	38.60	39.80	21.00	4.15	60.00	71.40	3.08
16BF5	25.40	15.88	12.70	8.28	30.80	32.10	20.00	3.5/3.0	50.00	57.50	2.37
16BH	25.40	15.88	17.02	8.90	35.70	38.90	24.10	4.0/3.1	80.00	94.20	3.11
24BH	38.10	25.40	25.40	14.63	58.60	63.40	36.20	7.5/6.0	225.00	250.30	9.00

Extended Pin Chain

ISO Chain No.	ANSI Chain No.	P	B	C	S	D	E
	35	9.525	4.77	3.58	9.50	20.80	21.60
	40	12.700	7.85	3.96	9.50	25.10	26.20
	50	15.875	9.40	5.08	11.90	31.30	33.10
	60	19.050	12.57	5.94	14.30	38.60	40.60
	80	25.400	15.75	7.92	19.10	50.30	53.30
	100	31.750	18.90	9.53	23.80	61.80	66.10
	120	38.100	25.22	11.10	28.60	76.40	80.40
	140	44.450	25.22	12.70	33.30	84.80	89.40
	160	50.800	31.55	14.27	38.10	99.60	104.40
08B		12.700	7.75	4.45	9.50	25.10	26.60
10B		15.875	9.65	5.08	11.90	30.10	31.50
12B		19.050	11.68	5.72	14.30	35.40	37.10
16B		25.400	17.02	8.28	19.10	53.00	54.30

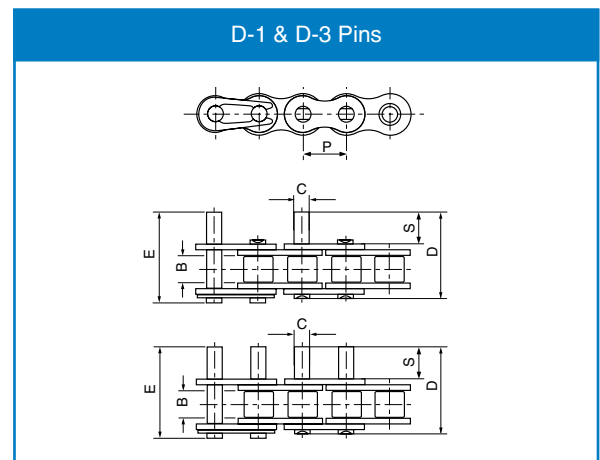

Standard boxed lengths are 5 metres
Special lengths available.

Roller Chain

Hollow Pin Chain

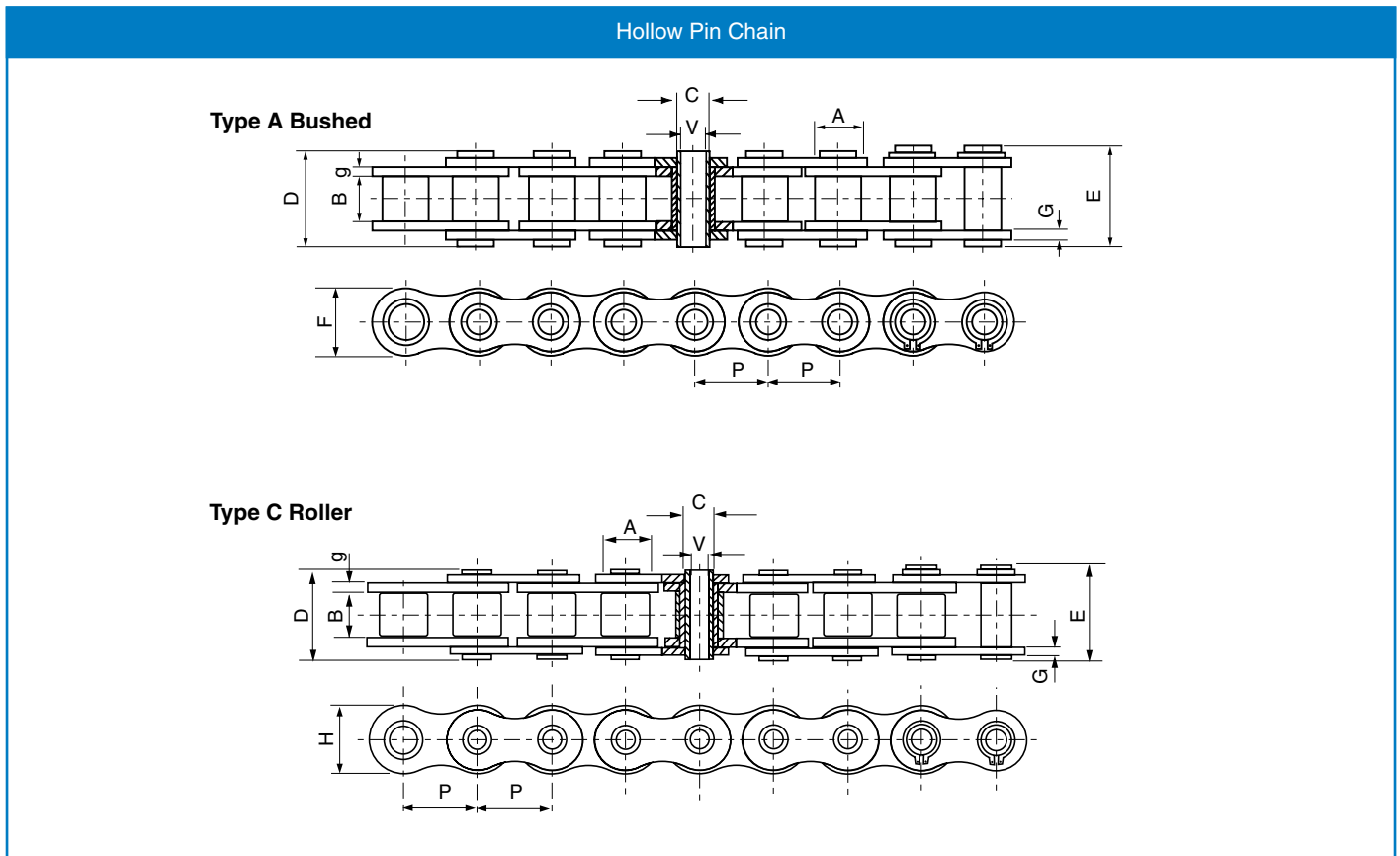

Chain number	Pitch	Roller/Bush diameter	Width between inner plates	Pin diameter		Pin length		Inner plate height	Plate thickness	Minimum tensile strength	Average tensile strength	Weight	Type form
	P	A	B	C	V	D	E	F	g/G	kN	kN	kg/m	
08BHP(4.0)	12.700	8.51	7.75	6.55	4.00	16.4	17.6	11.80	1.6/1.3	11.10	12.1	0.60	A
08BHP(4.5)	12.700	8.51	7.75	6.55	4.50	16.4	17.6	11.80	1.6/1.3	11.10	12.1	0.56	A
10BHP	15.875	10.16	9.65	5.94	4.04	19.3	20.6	14.70	1.70	17.00	20.8	0.86	C
12BHP	19.050	12.07	11.68	6.50	4.00	21.6	22.8	15.90	1.85	23.60	25.9	1.09	C
40HP	12.700	7.95	7.85	5.63	4.00	16.5	17.6	12.00	1.50	11.00	12.2	0.54	A
50HP	15.875	10.16	9.40	7.03	5.13	20.7	21.9	15.09	2.03	20.00	22.6	0.91	A
60HP	19.050	11.91	12.70	8.31	6.00	25.8	26.8	18.00	2.42	24.00	26.9	1.29	A
60HPF1	19.050	11.91	12.70	8.31	5.01	25.5	26.8	18.00	2.42	28.00	30.9	1.37	A
60HB	19.050	11.91	12.70	7.00	5.01	25.5	26.6	18.00	2.42	20.00	22.4	1.35	C
80HP	25.400	15.88	15.75	11.40	8.05	32.5	33.8	24.00	3.25	50.00	58.3	2.26	A

All dimensions in millimetres unless otherwise stated. Every effort has been taken to ensure that the data listed in this catalogue is correct. Challenge accepts no liability for any inaccuracies or damage caused.

Roller Chain

Special Chain - Challenge produce many special chains. The following pages are examples of a few. Contact Challenge for a quote on any special chains or attachments that aren't shown in our catalogue.

Special Chain with "U" Attachments

SIMPLEX

U1

U2

U3

DUPLEX

Chain number	Chain Pitch	Roller diameter	With between inner plates	Pin diameter	Side Plate Height	Pin length	Hole diameter	Hole pitch	Tensile strength			
	P	A	B	C	F	D	O	P ₁	X	N	S ₁	kN
08B-1/U1	12.700	8.51	7.75	4.45	11.8	20.4	-	-	14.4	24.0	8.5	14.60
08B-1/U2	12.700	8.51	7.75	4.45	11.8	20.4	5	-	14.4	24.0	8.5	14.60
08B-1/U3	12.700	8.51	7.75	4.45	11.8	20.4	5	12.7	14.4	24.0	8.5	14.60
08B-2/U1	12.700	8.51	7.75	4.45	11.8	34.4	-	-	28.4	24.0	8.1	28.60
08B-2/U2	12.700	8.51	7.75	4.45	11.8	34.4	4	14.0	28.4	24.0	8.1	28.60
08B-2/U3	12.700	8.51	7.75	4.45	11.8	34.4	4	12.7	28.4	24.0	8.1	28.60
10B-1/U1	15.875	10.16	9.65	5.08	14.7	22.8	-	-	16.4	30.0	10.6	18.20
10B-1/U2	15.875	10.16	9.65	5.08	14.7	22.8	5	-	16.4	30.0	10.6	18.20
10B-1/U3	15.875	10.16	9.65	5.08	14.7	22.8	5	15.8	16.4	30.0	10.6	18.20
10B-2/U1	15.875	10.16	9.65	5.08	14.7	39.0	-	-	33.3	30.0	10.6	36.30
10B-2/U2	15.875	10.16	9.65	5.08	14.7	39.0	5	16.6	33.3	30.0	10.6	36.30
10B-2/U3	15.875	10.16	9.65	5.08	14.7	39.0	5	15.8	33.3	30.0	10.6	36.30
12B-1/U1	19.050	12.07	11.68	5.72	16.0	26.5	-	-	19.4	35.0	13.0	23.60
12B-1/U2	19.050	12.07	11.68	5.72	16.0	26.5	5	-	19.4	35.0	13.0	23.60
12B-1/U3	19.050	12.07	11.68	5.72	16.0	26.5	5	19.0	19.4	35.0	13.0	23.60
12B-2/U1	19.050	12.07	11.68	5.72	16.0	46.5	-	-	39.4	35.0	12.0	46.60
12B-2/U2	19.050	12.07	11.68	5.72	16.0	46.5	5	19.5	39.4	35.0	12.0	46.60
12B-2/U3	19.050	12.07	11.68	5.72	16.0	46.5	5	19.0	39.4	35.0	12.0	46.60
16B-1/U1	25.400	15.88	17.02	8.28	21.0	39.2	-	-	29.4	49.0	15.4	58.00
16B-1/U2	25.400	15.88	17.02	8.28	21.0	39.2	5	-	29.4	49.0	15.4	58.00
16B-1/U3	25.400	15.88	17.02	8.28	21.0	39.2	5	25.4	29.4	49.0	15.4	58.00
16B-2/U1	25.400	15.88	17.02	8.28	21.0	73.0	-	-	29.4	49.0	15.4	98.00
16B-2/U2	25.400	15.88	17.02	8.28	21.0	73.0	5	-	29.4	49.0	15.4	98.00
16B-2/U3	25.400	15.88	17.02	8.28	21.0	73.0	5	25.4	29.4	49.0	15.4	98.00

Every effort has been taken to ensure that the data listed in this catalogue is correct. Challenge accepts no liability for any inaccuracies or damage caused. All dimensions in millimetres unless otherwise stated.

Roller Chain

Special Chain with "U" Attachments and Rubber Elements

Special Chain with "U" Attachments and Rubber Elements - Model UG1/UG2

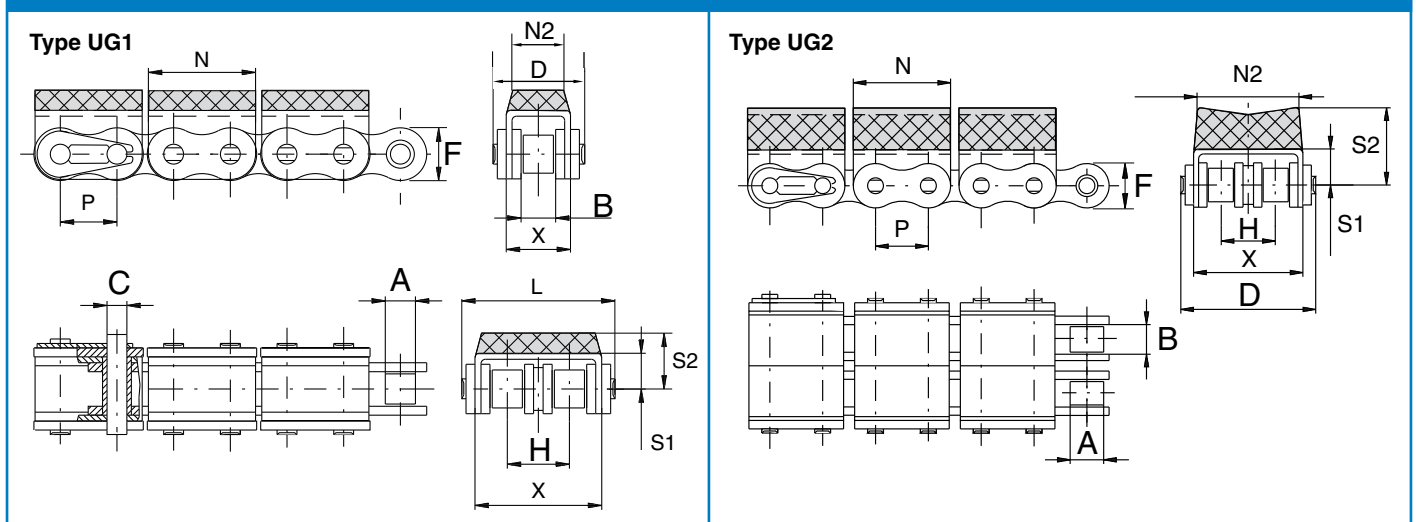

Special Chain with "U" Attachments and Rubber Elements - Model UGS

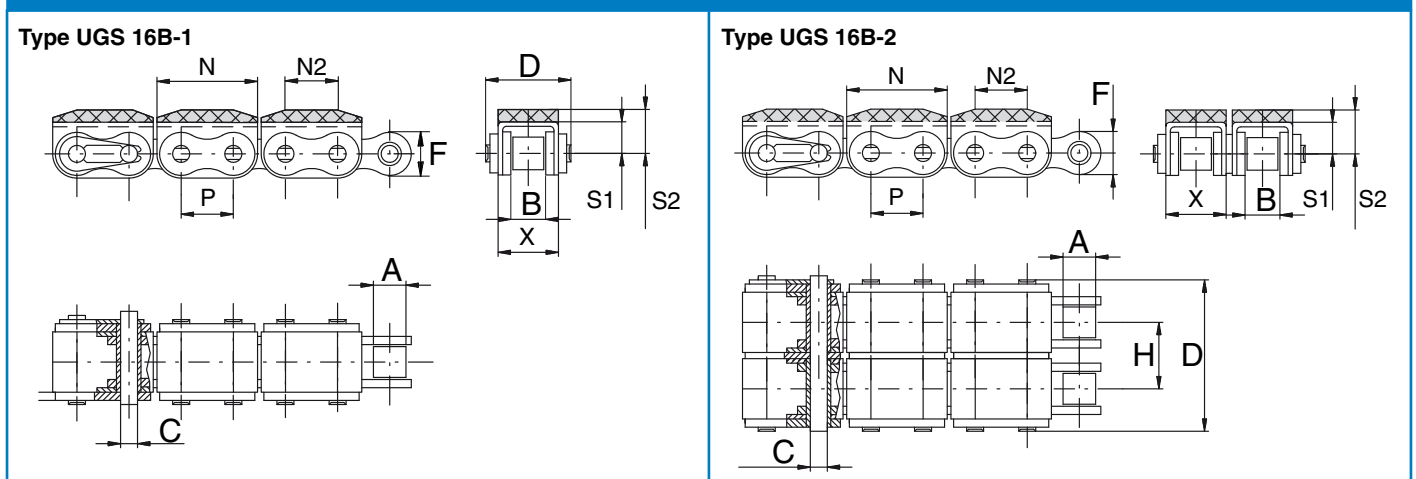

Chain Number	Chain Pitch	Roller diameter	With between inner plates	Pin diameter	Side Plate Height	Pin length	"U" profile	"U" profile	"U" profile	"U" Profile height	"U" Profile height	Transverse pitch	Min. Tensile strength
	P	A	B	C	F	D	X	N	N2	S1	S2	H	kN
08B-1/UG1	12.700	8.51	7.75	4.45	11.80	20.40	14.4	24	10.0	8.50	13.00	-	14.60
08B-2/UG1	12.700	8.51	7.75	4.45	11.80	34.40	28.4	24	20.0	8.10	12.50	13.92	28.60
10B-1/UG1	15.875	10.16	9.65	5.08	14.70	22.80	16.4	30	13.5	10.60	17.00	-	18.20
10B-2/UG1	15.875	10.16	9.65	5.08	14.70	39.00	33.3	30	30.0	10.60	15.50	16.59	36.30
12B-1/UG1	19.050	12.07	11.68	5.72	16.00	26.50	19.4	35	12.0	13.00	21.00	-	23.60
12B-2/UG1	19.050	12.07	11.68	5.72	16.00	46.50	39.4	35	36.0	12.00	20.00	19.46	46.60
16B-1/UG1	25.400	15.88	17.02	8.28	21.00	39.20	29.4	49	22.0	15.40	21.40	-	58.00
16B-2/UG1	25.400	15.88	17.02	8.28	21.00	73.00	29.4	49	22.0	15.40	21.40	31.88	98.00
12B-1/UG2	19.050	12.07	11.68	5.72	16.00	26.50	19.4	35	13.5	13.00	21.00	-	23.60
12B-2/UG2	19.050	12.07	11.68	5.72	16.00	46.50	39.4	35	36.0	12.00	28.00	19.46	46.60
16B-1/UGS	25.400	15.88	17.02	8.28	21.00	39.20	29.4	49	25.4	15.40	21.40	-	58.00
16B-2/UGS	25.400	17.02	15.88	8.28	21.00	73.00	29.4	49	25.4	15.40	21.40	31.88	98.00

All dimensions in millimetres unless otherwise stated. Every effort has been taken to ensure that the data listed in this catalogue is correct. Challenge accepts no liability for any inaccuracies or damage caused.

Roller Chain

Special Chain

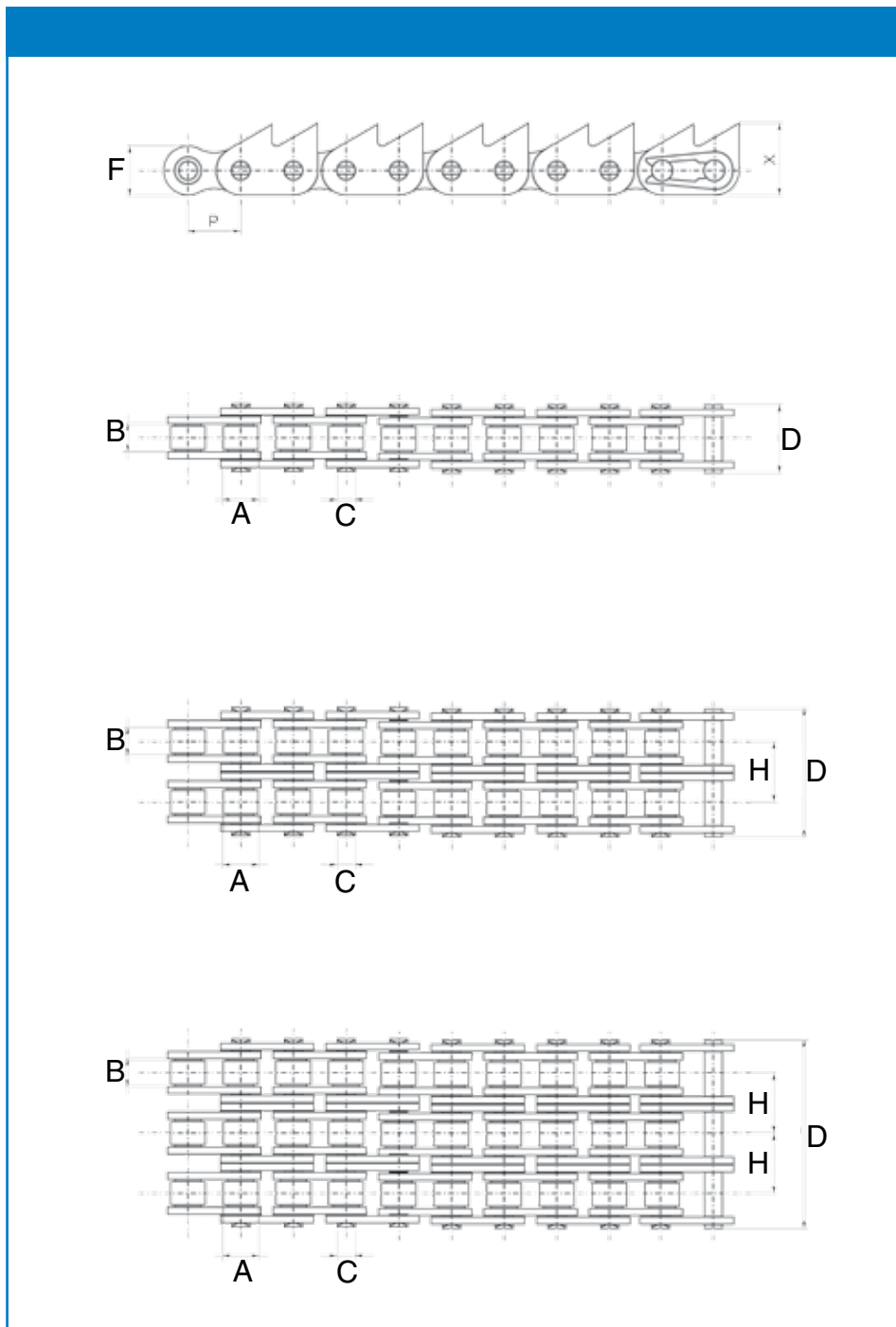

Chain number	Pitch P	Roller diameter A	With between inner plates B	Pin diameter C	Pin length D	Side Plate Height F	Transverse pitch H	Tooth height X	Tensile strength kN
16B-1Z	25.4	15.88	17.02	8.28	36.1	21.0	-	28	58
16B-2Z	25.4	15.88	17.02	8.28	68.0	21.0	31.88	28	110
16B-3Z	25.4	15.88	17.02	8.28	99.9	21.0	31.88	28	165

Roller Chain

Special Roller Chain

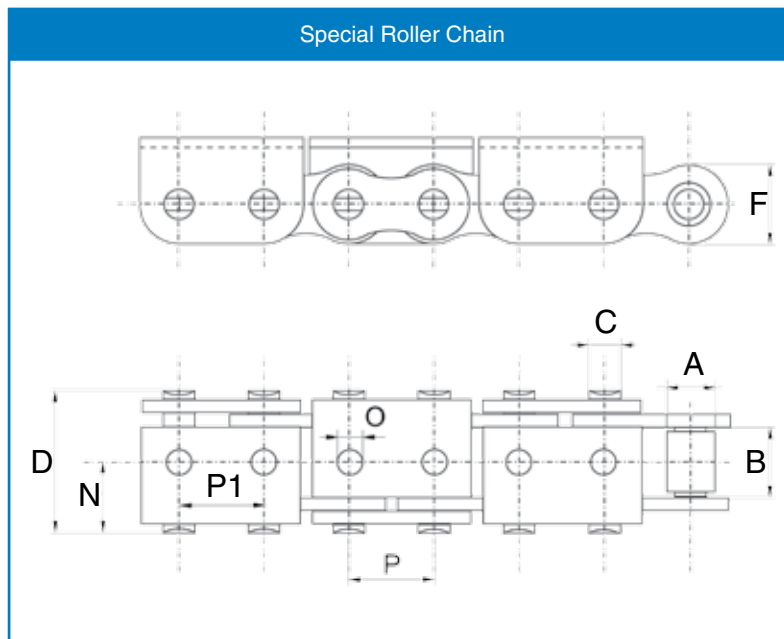

Chain number	Pitch	Width between inner plates	Roller diameter	Pin diameter	Pin length	Side plate height	Hole diameter	Hole pitch	Tensile strength	
	P	B	A	C	D	F	O	P1	N	
16B-1/P	25.4	17.02	15.88	8.28	36.1	21.0	6.5	25.4	15.9	58

Special Chain with Driver

Note: Various configurations of this chain are available.

Please provide dimensions when enquiring.

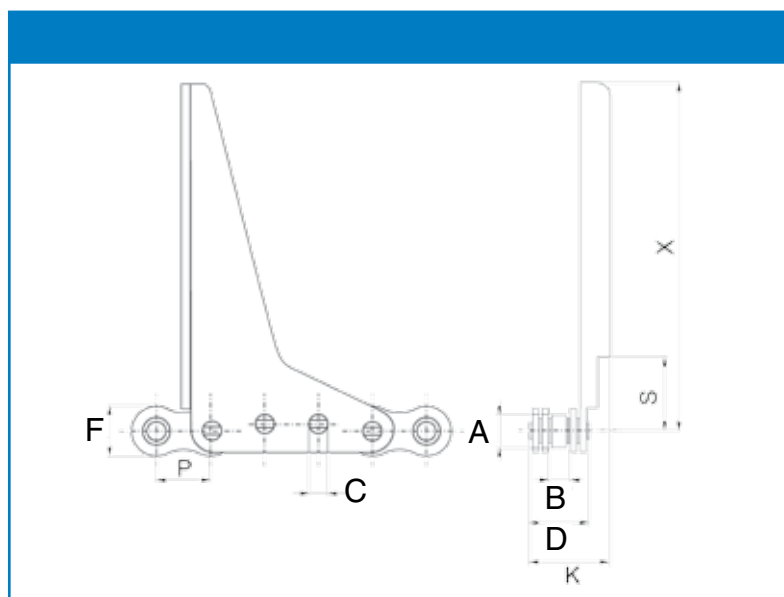

Chain number	Pitch	Roller diameter	Width between inner plates	Pin diameter	Pin length	Side plate height	Attachment width	Attachment height	Tensile strength	
	P	A	B	C	L	F	K	X	S	
08 X3/Z1	12.70	7.75	4.88	4.09	13.00	9.90	16.00	85.00	17.50	82.60

All dimensions in millimetres unless otherwise stated. Every effort has been taken to ensure that the data listed in this catalogue is correct. Challenge accepts no liability for any inaccuracies or damage caused.

Roller Chain

Accumulation Chain

Note: all accumulation chain is available with various accumulation roller dimensions as well as different pitch diameters to those quoted below.

To avoid confusion please always supply the chain and accumulation roller dimensions

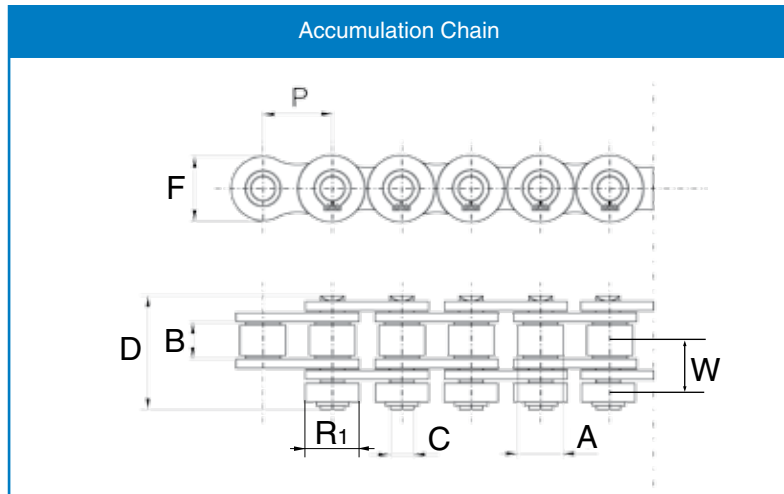

Chain number	Pitch	Roller diameter	Width between inner plates	Pin diameter	Pin length	Roller diameter	Roller pitch	Tensile strength
	P	A	B	C	D	R ₁	W	kN
10B-1/R	15.875	10.16	9.65	5.08	25.4	14.2	15.1	22.7

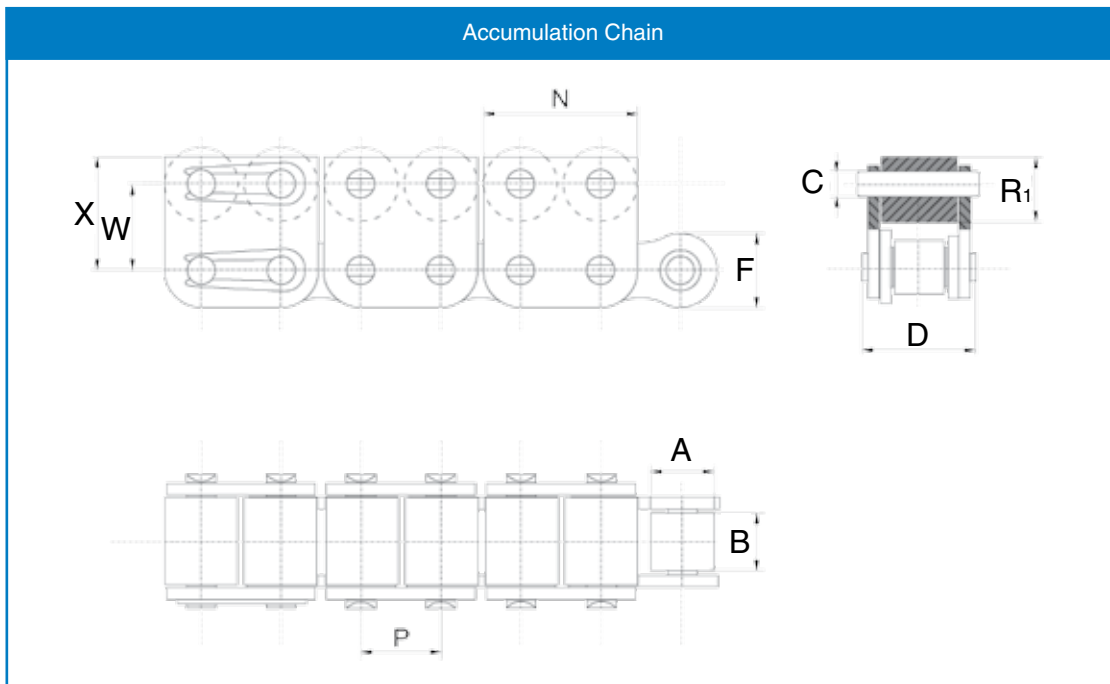

Chain number	Pitch	Roller diameter	Width between inner plates	Roller diameter	Pin diameter	Pin length	Inner plate height	Tensile strength			
	P	A	B	R ₁	C	D	F	W	X	N	kN
10B/R1	15.875	10.16	10.16	13.0	5.08	19.6	14.2	15.8	20.6	28.4	22.7

Every effort has been taken to ensure that the data listed in this catalogue is correct. Challenge accepts no liability for any inaccuracies or damage caused. All dimensions in millimetres unless otherwise stated.

Conveyor Chain

Accumulation Chain

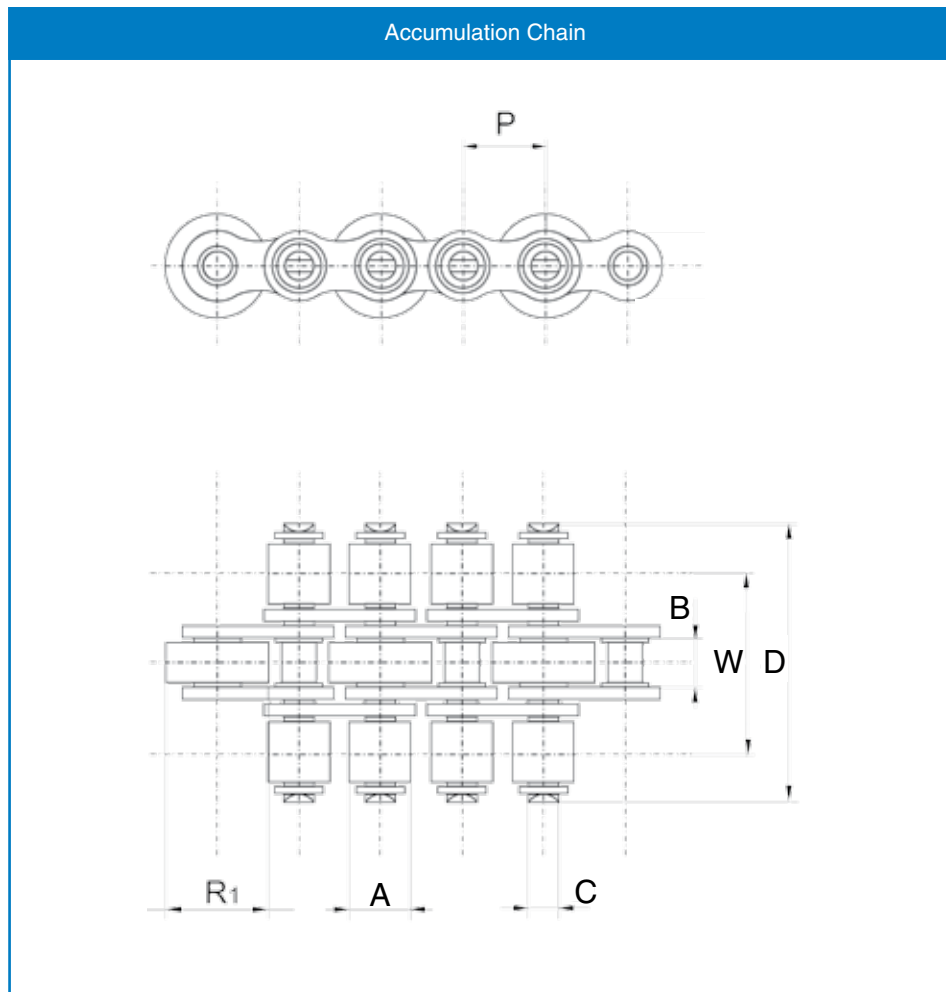

Chain number	Pitch P	Roller diameter. A	Width between inner plates B	Pin diameter C	Pin length D	Roller diameter R1	Roller pitch W	Tensile strength kN	Weight kg/m
08B-1/S6	12.70	8.51	7.75	4.47	27	16.0	19.1	18.2	1.17
08B-1/S7	12.70	8.51	7.75	4.47	33	16.0	22.0	18.2	1.38
12B-1/S1	19.05	12.07	11.68	5.72	48	26.0	31.5	29.5	3.50
12B-1/S2	19.05	12.07	11.68	5.72	43	26.0	29.2	29.5	3.20
12B-1/S2a	19.05	12.07	11.68	5.72	43	24.0	29.2	29.5	2.80
12B-1/S3	19.05	12.07	11.68	5.72	40	28.0	27.0	29.5	3.40
16B-1/S5	25.40	15.88	17.02	8.28	65	38.5	44.9	58.0	7.00

All dimensions in millimetres unless otherwise stated. Every effort has been taken to ensure that the data listed in this catalogue is correct. Challenge accepts no liability for any inaccuracies or damage caused.

Conveyor Chain

Accumulation Chain

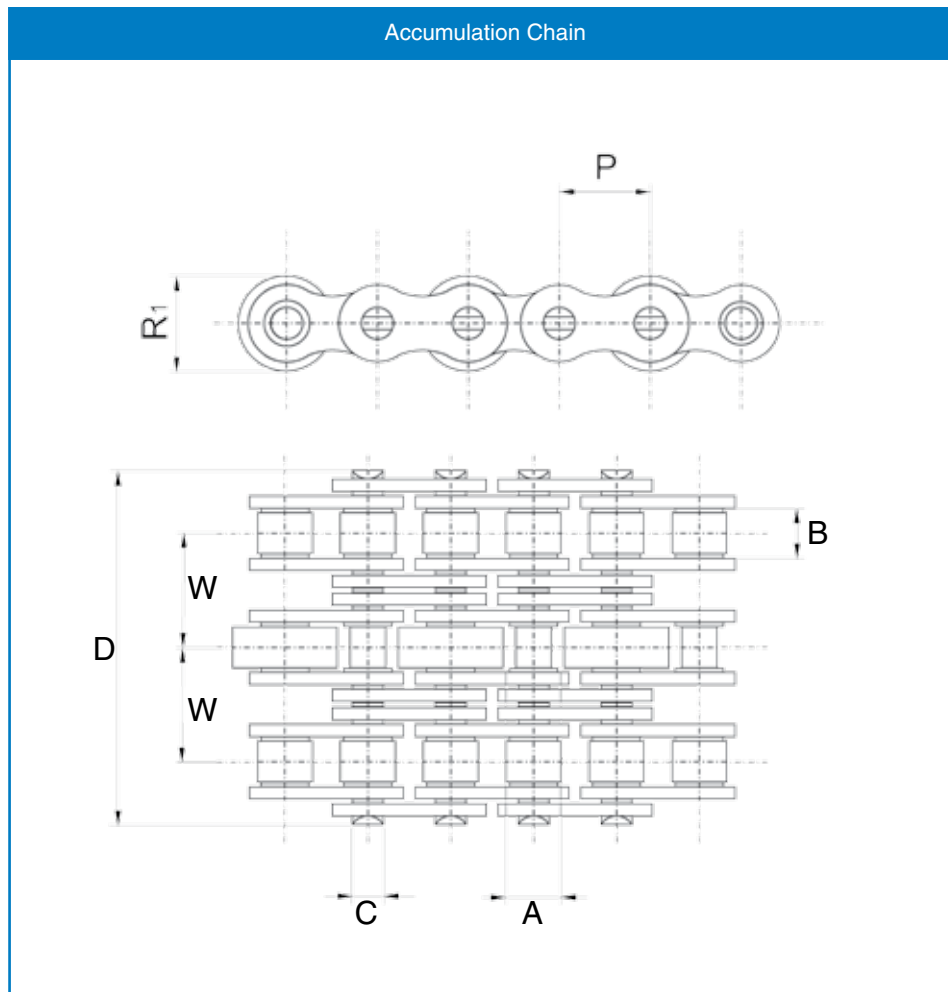

Chain number	Pitch	Roller diameter	Width between inner plate	Pin diameter	Pin length	Roller diameter	Roller pitch	Tensile strength
	P	A	B	C	D	R ₁	W	kN
12B-3/S2a	19.05	12.07	11.68	5.72	61.7	24.0	19.46	88.5
12B-3/S2	19.05	12.07	11.68	5.72	61.7	26.0	19.46	88.5

Roller Chain

Special Chain

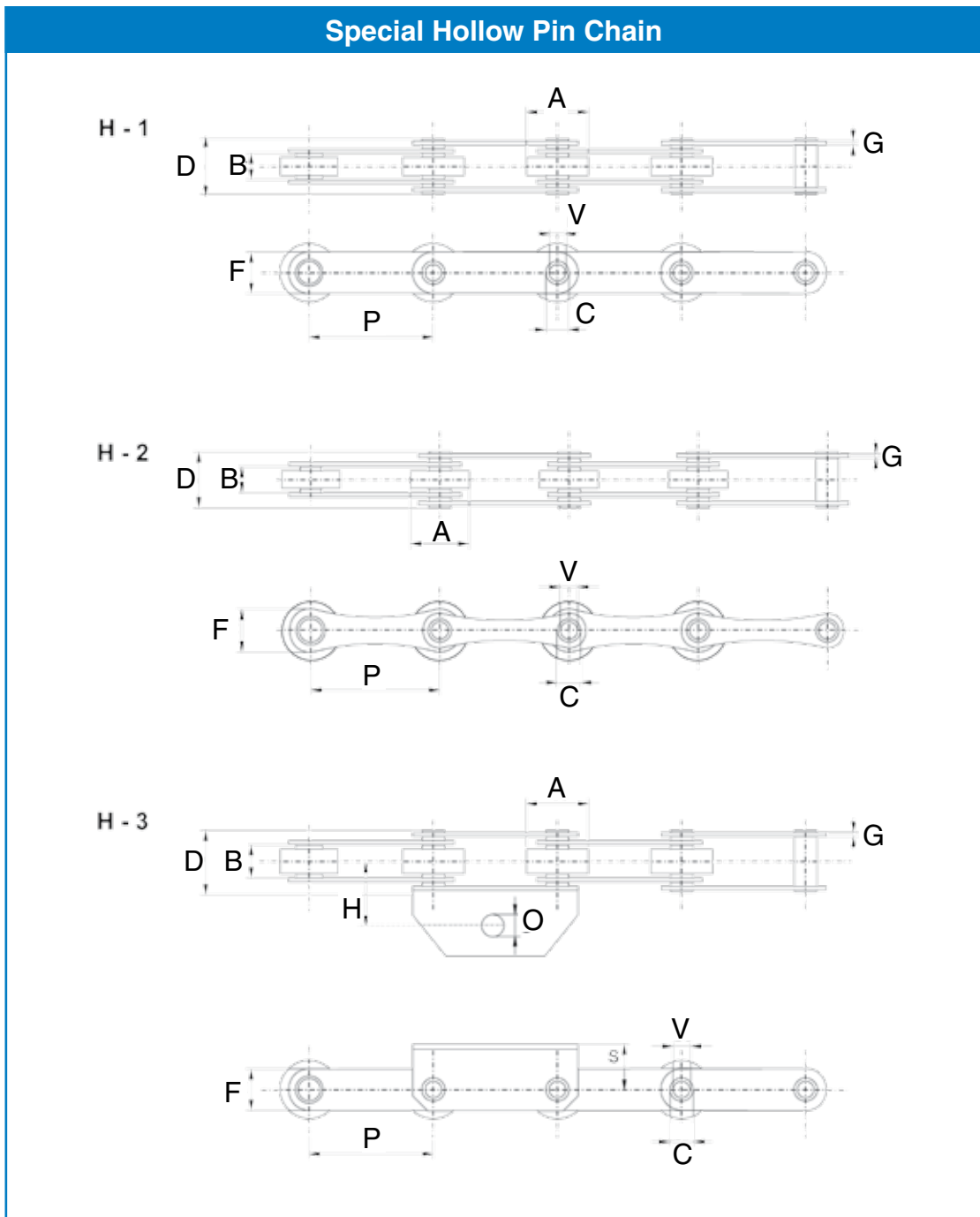

Chain	Pitch	Roller diameter	Width between inner plates	Pin diameter	Hollow bore diameter	Pin length	Side plate height	Plate thickness	Transverse pitch	Hole diameter	Tensile strength	Weight	
	P	A	B	C	V	D	F	G	S	H	O	kN	kg/m
H1	50.0	32.00	15.00	13.20	10.20	32.00	25.00	2.80	-	-	-	30	2.5
H2	50.8	30.00	10.00	11.50	8.30	26.00	21.00	3.00	-	-	-	30	2.3
H3	50.0	31.00	15.00	13.20	10.20	32.00	25.00	2.80	24.00	22.00	8.40	30	4.5

All dimensions in millimetres unless otherwise stated. Every effort has been taken to ensure that the data listed in this catalogue is correct. Challenge accepts no liability for any inaccuracies or damage caused.

Roller Chain

Stainless Steel Transmission Roller Chain (Grade 304)

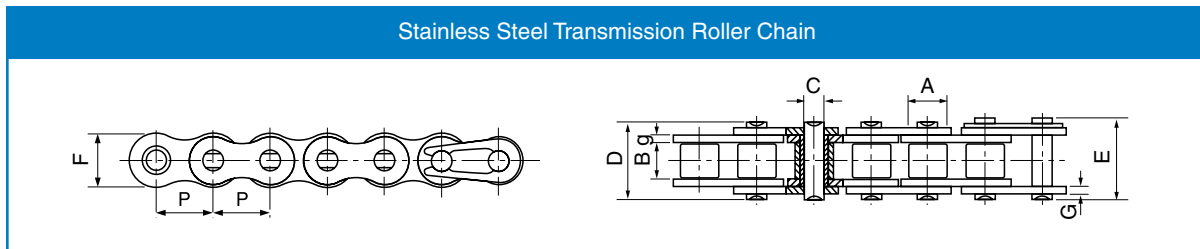

ISO Chain number	ANSI Chain number	Pitch P	Roller diameter		Pin diameter C	Pin length		Inner plate height F	Plate thickness g/G	Minimum tensile strength kN	Average tensile strength kN	Weight kg/m
			A	B		D	E					
	*35SS	9.525	5.08	4.77	3.58	12.40	13.17	9.00	1.30	5.50	6.60	0.33
	40SS	12.700	7.95	7.85	3.96	16.60	17.80	12.00	1.50	9.60	10.80	0.63
	50SS	15.875	10.16	9.40	5.08	20.70	22.20	15.09	2.03	15.20	17.20	1.03
	60SS	19.050	11.91	12.57	5.94	25.90	27.70	18.00	2.42	21.70	26.40	1.51
	80SS	25.400	15.88	15.75	7.92	32.70	35.00	24.00	3.25	38.90	46.60	2.62
	100SS	31.750	19.05	18.90	9.53	40.40	44.70	30.00	4.00	60.00	70.20	3.94
04BSS		6.000	4.00	2.80	1.85	6.80	7.80	5.00	0.60	2.00	2.40	0.11
05BSS		8.000	5.00	3.00	2.31	8.20	8.90	7.10	0.80	3.50	4.10	0.20
#06BSS		9.525	6.35	5.72	3.28	13.15	14.10	8.20	1.30	6.20	6.80	0.41
08BSS		12.700	8.51	7.75	4.45	16.70	18.20	11.80	1.60	12.00	14.30	0.70
10BSS		15.875	10.16	9.65	5.08	19.50	20.90	14.70	1.70	14.50	17.20	0.94
12BSS		19.050	12.07	11.68	5.72	22.50	24.20	16.00	1.85	18.50	20.90	1.16
16BSS		25.400	15.88	17.02	8.28	36.10	37.40	21.00	4.15/3.1	40.00	47.60	2.73
20BSS		31.750	19.05	19.56	10.19	41.30	45.00	26.40	4.5/3.5	59.00	69.60	3.73

* Bush chain: **A** in the table indicates the external diameter of the bush
 # Straight side plate chain

Standard boxed lengths are 5 metres
 Special lengths available.

Roller Chain

Nickel Plated Transmission Roller Chain

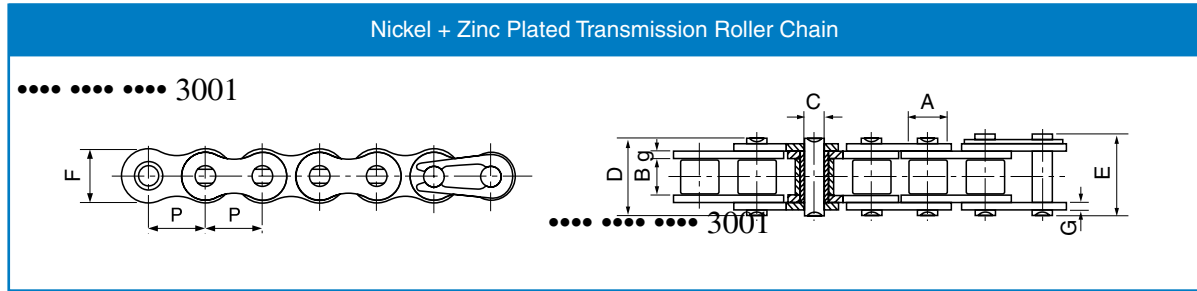

ISO Chain number	ANSI Chain number	Pitch	Roller diameter	Width between inner plates	Pin diameter	Pin length		Inner plate height F	Plate thickness g/G	Minimum tensile strength kN	Average tensile strength kN	Weight kg/m
		P	A	B	C	D	E					
	*25NP	6.350	3.30	3.18	2.31	7.90	8.40	6.00	0.80	3.50	4.60	0.15
	*35NP	9.525	5.08	4.77	3.58	12.40	13.17	9.00	1.30	7.90	10.80	0.33
	41NP	12.700	7.77	6.25	3.58	13.75	15.00	9.91	1.30	6.67	12.60	0.41
	40NP	12.700	7.95	7.85	3.96	16.60	17.80	12.00	1.50	14.10	17.50	0.62
	50NP	15.875	10.16	9.40	5.08	20.70	22.20	15.09	2.03	22.20	29.40	1.02
	60NP	19.050	11.91	12.57	5.94	25.90	27.70	18.00	2.42	31.80	41.50	1.50
	80NP	25.400	15.88	15.75	7.92	32.70	35.00	24.00	3.25	56.70	69.40	2.60
	100NP	31.750	19.05	18.90	9.53	40.40	44.70	30.00	4.00	88.50	109.20	3.91
04BNP		6.000	4.00	2.80	1.85	6.80	7.80	5.00	0.60	3.00	3.20	0.11
05BNP		8.000	5.00	3.00	2.31	8.20	8.90	7.10	0.80	5.00	5.90	0.20
#06BNP		9.525	6.35	5.72	3.28	13.15	14.10	8.20	1.30	9.00	10.40	0.41
08BNP		12.700	8.51	7.75	4.45	16.70	18.20	11.80	1.60	18.00	19.40	0.69
10BNP		15.875	10.16	9.65	5.08	19.50	20.90	14.70	1.70	22.40	27.50	0.93
12BNP		19.050	12.07	11.68	5.72	22.50	24.20	16.00	1.85	29.00	32.20	1.15
16BNP		25.400	15.88	17.02	8.28	36.10	37.40	21.00	4.15/3.1	60.00	72.80	2.71
20BNP		31.750	19.05	19.56	10.19	41.30	45.00	26.40	4.5/3.5	95.00	106.70	3.70

Zinc Plated Transmission Roller Chain

ISO Chain number	ANSI Chain number	Pitch	Roller diameter	Width between inner plates	Pin diameter	Pin length		Inner plate height F	Plate thickness g/G	Minimum tensile strength kN	Average tensile strength kN	Weight kg/m
		P	A	B	C	D	E					
	*25ZP	6.350	3.30	3.18	2.31	7.90	8.40	6.00	0.80	3.50	4.60	0.14
	*35ZP	9.525	5.08	4.77	3.58	12.40	13.17	9.00	1.30	7.90	10.80	0.33
	41ZP	12.700	7.77	6.25	3.58	13.75	15.00	9.91	1.30	6.67	12.60	0.41
	40ZP	12.700	7.95	7.85	3.96	16.60	17.80	12.00	1.50	14.10	17.50	0.62
	50ZP	15.875	10.16	9.40	5.08	20.70	22.20	15.09	2.03	22.20	29.40	1.02
	60ZP	19.050	11.91	12.57	5.94	25.90	27.70	18.00	2.42	31.80	41.50	1.50
	80ZP	25.400	15.88	15.75	7.92	32.70	35.00	24.00	3.25	56.70	69.40	2.60
	100ZP	31.750	19.05	18.90	9.53	40.40	44.70	30.00	4.00	88.50	109.20	3.91
04BZP		6.000	4.00	2.80	1.85	6.80	7.80	5.00	0.60	3.00	3.20	0.11
05BZP		8.000	5.00	3.00	2.31	8.20	8.90	7.10	0.80	5.00	5.90	0.20
#06BZP		9.525	6.35	5.72	3.28	13.15	14.10	8.20	1.30	9.00	10.40	0.41
08BZP		12.700	8.51	7.75	4.45	16.70	18.20	11.80	1.60	18.00	19.40	0.69
10BZP		15.875	10.16	9.65	5.08	19.50	20.90	14.70	1.70	22.40	27.50	0.93
12BZP		19.050	12.07	11.68	5.72	22.50	24.20	16.00	1.85	29.00	32.20	1.15
16BZP		25.400	15.88	17.02	8.28	36.10	37.40	21.00	4.15/3.1	60.00	72.80	2.71
20BZP		31.750	19.05	19.56	10.19	41.30	45.00	26.40	4.5/3.5	95.00	106.70	3.70

* Bush chain: A in the table indicates the external diameter of the bush

Straight side plate chain

Standard boxed lengths are 5 metres

Special lengths available.

Roller Chain

Side Bow Chain with Loose Tolerance Pin

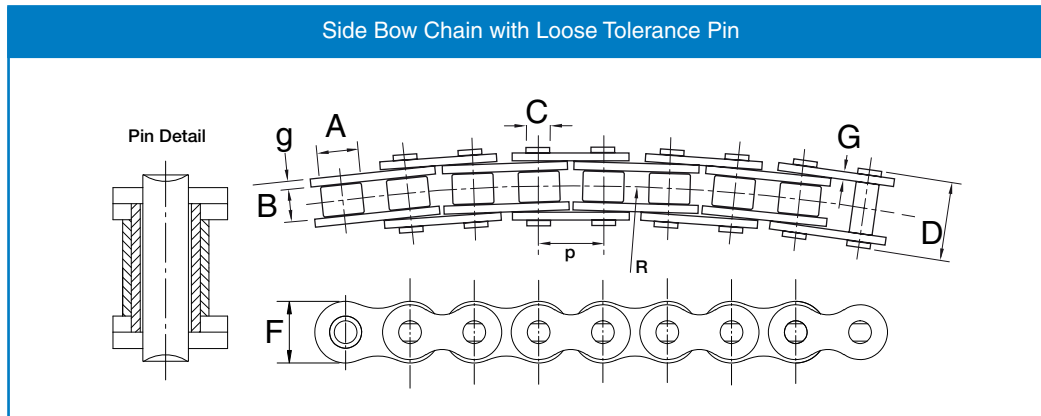

Chain number	Pitch	Roller diameter	Width between inner plates	Pin diameter	Pin length	Inner plate height	Plate thickness	Min. side bow radius	Average tensile strength	Weight
	P	A	B	C	D	F	g/G	R	kN	kg/m
40SB	12.700	7.95	7.85	3.45	16.9	11.7	1.50	350	11.00	0.80
50SB	15.875	10.16	9.40	4.37	20.7	14.9	2.03	400	20.00	1.09
60SB	19.050	11.91	12.57	5.34	26.6	18.0	2.42	500	28.00	1.54
63SB	19.050	11.91	12.68	5.08	28.8	17.2	2.42 / 2.03	350	25.00	1.40
80SB	25.400	15.88	15.75	7.19	34.0	24.0	3.25	715	39.00	2.60
08BSB	12.700	8.51	7.75	3.97	17.4	11.8	1.50	400	11.20	0.70
08BSBF1	12.700	8.51	7.75	3.97	16.3	11.8	1.60 / 1.20	400	11.00	0.65
10BSB	15.875	10.16	9.65	4.50	20.1	14.7	1.70	400	18.70	0.93
12BSB	19.050	12.07	11.68	5.12	23.1	16.0	1.85	500	21.00	1.16
16BSB	25.400	15.88	17.22	7.90	36.5	21.0	3.70 - 3.00	500	53.50	2.53

Side Bow Chain with Conical Pin

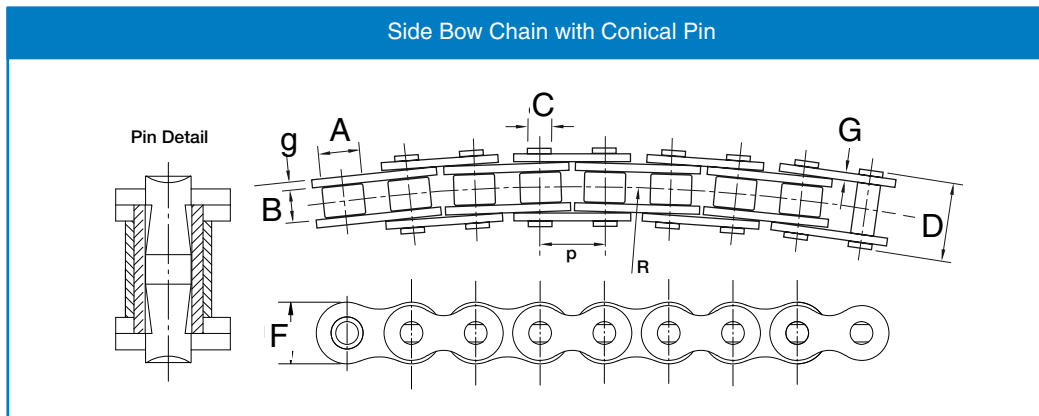

Chain number	Pitch	Roller diameter	Width between inner plates	Pin diameter	Pin length	Inner plate height	Plate thickness	Min. side bow radius	Average tensile strength	Weight
	P	A	B	C	D	F	g/G	R	kN	kg/m
40SB	12.700	7.95	7.85	3.98	16.9	11.7	1.50	350	11.00	0.80
50SB	15.875	10.16	9.40	5.08	20.7	14.9	2.03	400	20.00	1.09
60SB	19.050	11.91	12.57	5.94	26.6	18.0	2.42	500	28.00	1.54
80SB	25.400	15.88	15.75	7.92	34.0	24.0	3.25	711	39.00	2.60
08BSB	12.700	8.51	7.75	4.45	17.4	11.8	1.50	400	11.20	0.70
08BSBF1	12.700	8.51	7.75	4.45	16.3	11.8	1.60 - 1.20	400	11.00	0.65
10BSB	15.875	10.16	9.65	5.08	20.1	14.7	1.70	400	18.70	0.93
12BSB	19.050	12.07	11.68	5.72	23.1	16.0	1.85	500	21.00	1.16
16BSB	25.400	15.88	17.22	8.28	36.5	21.0	3.70 - 3.00	500	53.50	2.53
C2050SB	31.750	10.16	9.40	5.08	21.3	15.0	2.03	800	20.50	0.84

Every effort has been taken to ensure that the data listed in this catalogue is correct. Challenge accepts no liability for any inaccuracies or damage caused. All dimensions in millimetres unless otherwise stated.

Roller Chain Attachments

A-1 & K-1 Attachments

ISO No.	ANSI No.	P	I	J	K	L	M	O
	40	12.700	9.50	25.40	35.20	1.50	7.90	3.40
	50	15.875	12.70	31.75	46.20	2.03	10.30	5.50
	60	19.050	15.90	38.10	55.60	2.42	11.90	5.50
	80	25.400	19.10	50.80	64.80	3.25	15.90	6.80
	100	31.750	25.40	63.50	87.30	4.00	19.80	9.20
	120	38.100	28.60	76.20	108.50	4.80	23.00	9.80
	140	44.450	34.90	88.90	123.00	5.60	28.60	11.40
	160	50.800	38.10	101.60	142.80	6.40	31.80	13.10
*06B		9.525	8.00	19.04	27.00	1.30	6.50	3.50
08B		12.700	9.50	25.40	36.40	1.60	8.90	4.50
10B		15.875	14.30	31.75	44.60	1.70	10.31	5.30
12B		19.050	16.00	38.10	52.40	1.85	13.46	6.40
16B		25.400	19.10	50.80	72.60	3.10	15.88	6.40

A1 & K1 Attachments

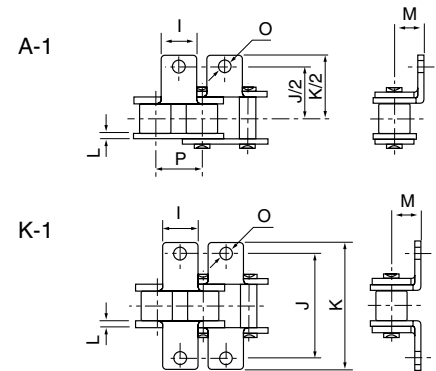

SA-1 & SK-1 Attachments

ISO No.	ANSI No.	P	I	J	Q	L	O
	40	12.700	9.50	19.05	12.70	1.50	3.40
	50	15.875	12.70	25.25	15.90	2.03	5.50
	60	19.050	15.90	29.33	18.30	2.42	5.50
	80	25.400	19.10	34.70	24.60	3.25	6.80
	100	31.750	25.40	43.30	31.80	4.00	9.20
	120	38.100	28.60	51.60	36.50	4.80	9.80
	140	44.450	34.90	62.00	44.50	5.60	11.40
	160	50.800	38.10	69.85	50.80	6.40	13.10
*06B		9.525	8.00	13.50	9.52	1.30	3.50
08B		12.700	9.50	18.90	13.35	1.60	4.30
10B		15.875	14.30	22.95	16.50	1.70	5.30
12B		19.050	16.00	28.60	21.45	1.85	6.40
16B		25.400	19.10	34.00	23.15	3.10	6.40

SA-1 & SK-1 Attachments

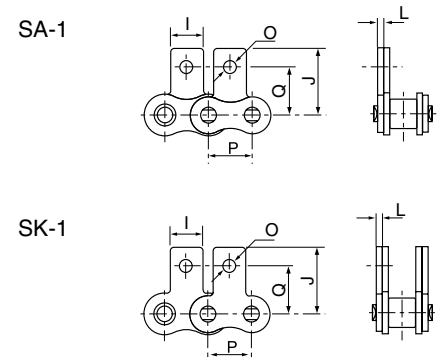

WA-2 & WK-2 Attachments

ISO No.	ANSI No.	P	I	R	J	K	L	M	O
	40	12.700	23.00	12.70	25.40	35.60	1.50	7.90	3.40
	50	15.875	28.80	15.88	31.80	46.80	2.03	10.30	5.50
	60	19.050	34.65	19.05	38.10	56.40	2.42	11.90	5.50
	80	25.400	45.90	25.40	50.80	73.20	3.25	15.90	6.80
	100	31.750	57.65	31.75	63.50	89.80	4.00	19.80	9.20
08B		12.700	24.00	12.70	25.40	36.40	1.60	8.90	4.30
10B		15.875	29.58	15.88	31.80	44.60	1.70	10.31	5.30
12B		19.050	34.05	19.05	38.10	52.40	1.85	13.46	6.40
16B		25.400	46.40	25.40	50.80	72.60	3.10	15.88	6.40

WA-2 & WK-2 Attachments

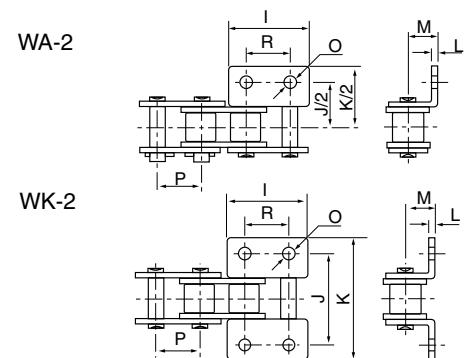

WSA-2 & WSK-2 Attachments

ISO No.	ANSI No.	P	I	R	J	Q	L	O
	40	12.700	23.00	12.70	17.40	12.70	1.50	3.40
	50	15.875	28.80	15.88	23.05	15.90	2.03	5.50
	60	19.050	34.65	19.05	26.86	18.30	2.42	5.50
	80	25.400	45.90	25.40	35.45	24.60	3.25	6.80
	100	31.750	57.65	31.75	44.00	31.80	4.00	9.20
08B		12.700	23.30	12.70	18.90	13.35	1.60	4.30
10B		15.875	29.58	15.88	22.95	16.50	1.70	5.30
12B		19.050	34.05	19.05	28.60	21.45	1.85	6.40
16B		25.400	46.40	25.40	34.00	23.15	3.10	6.40

WSA-2 & WSK-2 Attachments

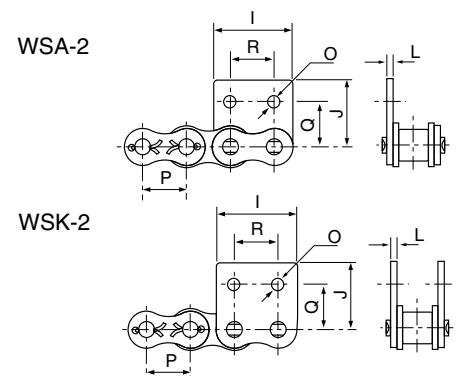

* Straight side plates

All dimensions in millimetres unless otherwise stated. Every effort has been taken to ensure that the data listed in this catalogue is correct. Challenge accepts no liability for any inaccuracies or damage caused.

Roller Chain Attachments

Attachment Chain Designation

Packed in 5m Boxes

1. Standard Chains with bent attachment A1 - one hole - one side - every outer

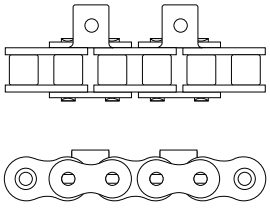

Chain Reference
06BA-2
08BA-2
10BA-2
12BA-2
16BA-2

7. Standard Chains with straight attachment SA1 - one hole - one side - every outer

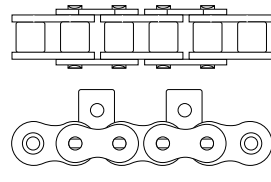

Chain Reference
06BSA-2
08BSA-2
10BSA-2
12BSA-2
16BSA-2

2. Standard Chains with bent attachment K1 - one hole - both sides - every outer

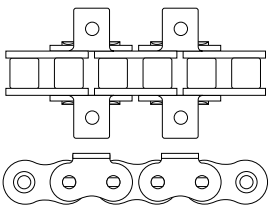

Chain Reference
06BK-2
08BK-2
10BK-2
12BK-2
16BK-2

8. Standard Chains with straight attachment SK1 - one hole - both sides - every outer

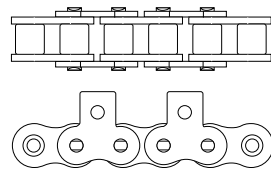

Chain Reference
06BSK-2
08BSK-2
10BSK-2
12BSK-2
16BSK-2

3. Standard Chains with bent attachment A1 - one hole - one side - every outer and inner

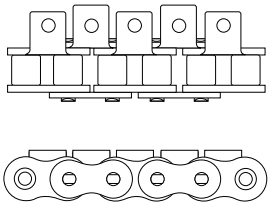

Chain Reference
06BA-1
08BA-1
10BA-1
12BA-1
16BA-1

9. Standard Chains with straight attachment SA1 - one hole - one side - every outer and inner

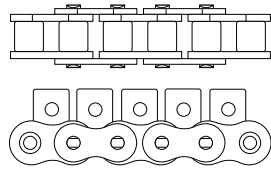

Chain Reference
06BSA-1
08BSA-1
10BSA-1
12BSA-1
16BSA-1

4. Standard Chains with bent attachment K1 - one hole - both sides - every outer and inner

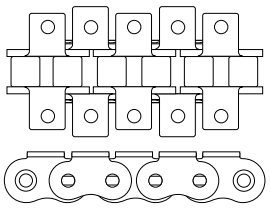

Chain Reference
06BK-1
08BK-1
10BK-1
12BK-1
16BK-1

10. Standard Chains with straight attachment SK1 - one hole - both sides - every outer and inner

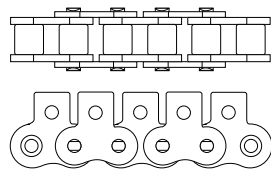

Chain Reference
06BSK-1
08BSK-1
10BSK-1
12BSK-1
16BSK-1

5. Standard Chains with bent attachment WA2 - two holes - one side - every outer

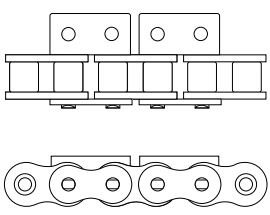

Chain Reference
06BWA-2
08BWA-2
10BWA-2
12BWA-2
16BWA-2

11. Standard Chains with straight attachment WSA2 - two holes - one side - every outer

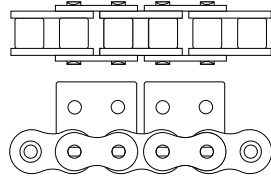

Chain Reference
06BWSA-2
08BWSA-2
10BWSA-2
12BWSA-2
16BWSA-2

6. Standard Chains with bent attachment WK2 - two holes - both sides - every outer

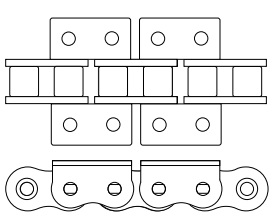

Chain Reference
06BWK-2
08BWK-2
10BWK-2
12BWK-2
16BWK-2

12. Standard Chains with straight attachment WSK2 - two holes - both sides - every outer

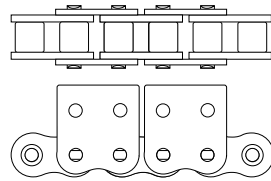

Chain Reference
06WSK-2
08BWSK-2
10BWSK-2
12BWSK-2
16BWSK-1

Every effort has been taken to ensure that the data listed in this catalogue is correct. Challenge accepts no liability for any inaccuracies or damage caused. All dimensions in millimetres unless otherwise stated.

Roller Chain Attachments

Roller Chain with Special Straight and Sharp Plates

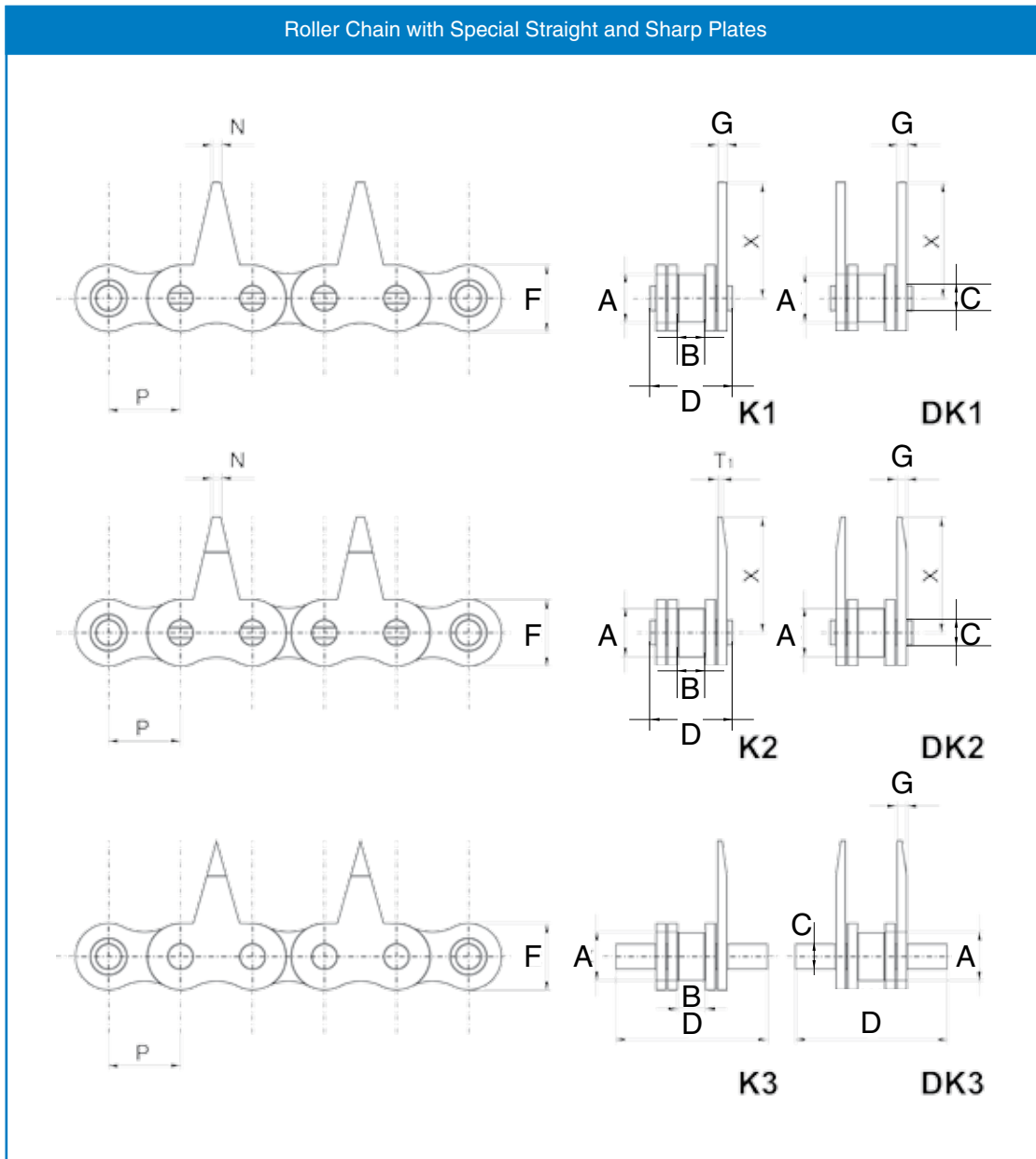

Chain number	Pitch	Roller diameter	Width between inner plates	Pin diameter	Side plate height	Plate thickness	Pin length	Attachment height	Tensile strength		
	P	A	B	C	F	G	L	T1	X	N	kN
08 B/K1	12.70	8.51	7.75	4.45	10.80	1.60	16.70	-	14.5	1.2	18.2
08 B/K2	12.70	8.51	7.75	4.45	10.80	1.60	16.70	0.3	14.5	1.2	18.2
12 B/K3	19.05	12.07	11.68	5.71	16.13	1.85	29.35	-	14.5	-	29.5

All dimensions in millimetres unless otherwise stated. Every effort has been taken to ensure that the data listed in this catalogue is correct. Challenge accepts no liability for any inaccuracies or damage caused.

Double Pitch Chain

Double Pitch Transmission Chain

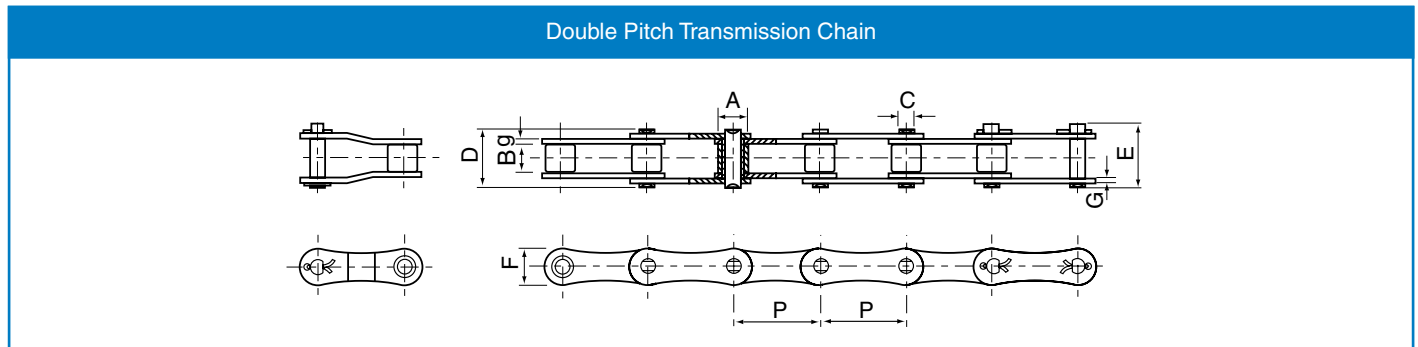

ISO Chain number	ANSI Chain number	Pitch	Roller diameter	Width between inner plates	Pin diameter	Pin length		Inner plate height	Plate thickness g/G	Minimum tensile strength kN	Average tensile strength kN	Weight kg/m
		P	A	B	C	D	E	F				
	A2040	25.40	7.95	7.85	3.96	16.60	17.80	12.00	1.50	14.10	16.70	0.42
208B		25.40	8.51	7.75	4.45	16.70	18.20	11.80	1.60	18.00	19.40	0.45
	A2050	31.75	10.16	9.40	5.08	20.70	22.20	15.00	2.03	22.20	28.10	0.73
210B		31.75	10.16	9.65	5.08	19.50	20.90	14.70	1.70	22.40	27.50	0.65
	A2060	38.10	11.91	12.57	5.94	25.90	27.70	18.00	2.42	31.80	36.80	1.02
212B		38.10	12.07	11.68	5.72	22.50	25.20	16.00	1.85	29.00	32.20	0.76
	A2080	50.80	15.88	15.75	7.92	32.70	36.50	24.00	3.25	56.70	65.70	1.70
216AH		50.80	15.88	15.75	7.92	36.20	39.40	24.00	4.00	56.70	70.00	2.17
216B		50.80	15.88	17.02	8.28	36.10	39.10	21.00	4.15/3.1	60.00	72.80	1.75
	A2100	63.50	19.05	18.90	9.53	40.40	44.70	30.00	4.00	88.50	102.60	2.55
220B		63.50	19.05	19.56	10.19	41.30	45.00	26.40	4.5/3.5	95.00	106.70	2.62
	A2120	76.20	22.23	25.22	11.10	50.30	54.30	35.70	4.80	127.00	147.30	4.06
224B		76.20	25.40	25.40	14.63	53.40	57.80	33.20	6.0/4.8	160.00	178.00	4.70
228B		88.90	27.94	30.99	15.90	65.10	69.50	36.70	7.5/6.0	200.00	222.00	6.23
232B		101.60	29.21	30.99	17.81	66.00	71.00	42.00	7.0/6.0	250.00	277.50	6.72

Standard boxed lengths are 5 metres
Special lengths available.

Double Pitch Chain

Double Pitch Conveyor Chain

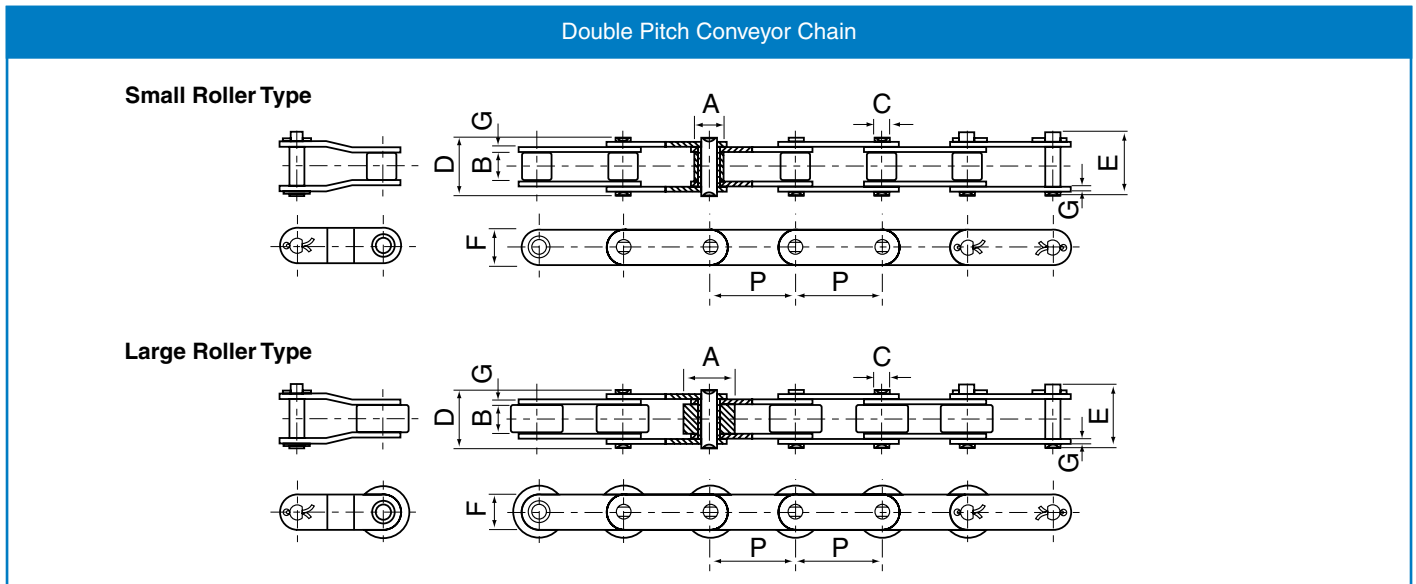

ISO Chain number	ANSI Chain number	Pitch P	Roller diameter A	Width between inner plates		Pin length		Side plate height F	Plate thickness G	Minimum tensile strength kN	Average tensile strength kN	Weight kg/m
				B	C	D	E					
	C2040	25.40	7.95	7.85	3.96	16.60	17.80	12.00	1.50	14.10	16.70	0.50
	C2042		15.88									
C208B C208BL	C2040H	25.40	7.95	7.85	3.96	18.80	19.90	12.00	2.03	14.10	17.20	0.65
			8.51									
			15.88									0.89
	C2050	31.75	10.16	9.40	5.08	20.70	22.20	15.00	2.03	22.20	28.10	0.78
	C2052		19.05									1.27
	C2060	38.10	11.91	12.57	5.94	25.90	27.70	18.00	2.42	31.80	36.80	1.12
	C2062		22.23									
	C2060H	38.10	11.91	12.57	5.94	29.20	31.60	18.00	3.25	31.80	41.60	1.44
	C2062H		22.23									
	C2080	50.80	15.88	15.75	7.92	32.70	36.50	24.00	3.25	56.70	65.70	2.08
	C2082		28.58									
	C2080H	50.80	15.88	15.75	7.92	36.20	39.40	24.40	4.00	56.70	70.00	2.54
	C2082H		28.58									
	C2100	63.50	19.05	18.90	9.53	40.40	44.70	30.00	4.00	88.50	102.60	3.01
	C2102		39.67									
	C2100H	63.50	19.05	18.90	9.53	43.60	46.90	30.00	4.80	88.50	112.40	3.56
	C2102H		39.67									
	C2120	76.20	22.23	25.22	11.10	50.30	54.30	35.70	4.80	127.00	147.30	4.66
	C2122		44.45									
	C2120H	76.20	22.23	25.22	11.10	53.50	57.50	35.70	5.60	127.00	160.90	5.26
	C2122H		44.45									
	C2160	101.60	28.58	31.75	14.27	64.80	69.60	47.80	6.40	226.80	278.90	8.23
	C2162		57.15									
	C2160H	101.60	28.58	31.75	14.27	68.20	73.00	47.80	7.20	226.80	285.80	9.06
	C2162H		57.15									

Standard boxed lengths are 5 metres
Special lengths available.

All dimensions in millimetres unless otherwise stated. Every effort has been taken to ensure that the data listed in this catalogue is correct. Challenge accepts no liability for any inaccuracies or damage caused.

Double Pitch Attachments

K-1 & SK-1 Attachments

ANSI Chain number	P	I	J	K	M	O	Q	T	U
A2040	25.40	19.1	25.4	39.6	9.1	3.4	11.1	20.5	5.5
A2050	31.75	23.8	31.8	49.0	11.1	5.5	14.3	25.0	6.6
A2060	38.10	28.6	42.9	67.8	14.7	5.5	17.5	32.9	9.2
A2080	50.80	38.1	55.6	87.8	19.1	6.8	22.2	43.5	11.0
A2100	63.50	47.6	66.6	107.5	23.4	9.2	28.6	50.4	13.0
A2120	76.20	57.2	79.3	127.5	27.8	11.0			

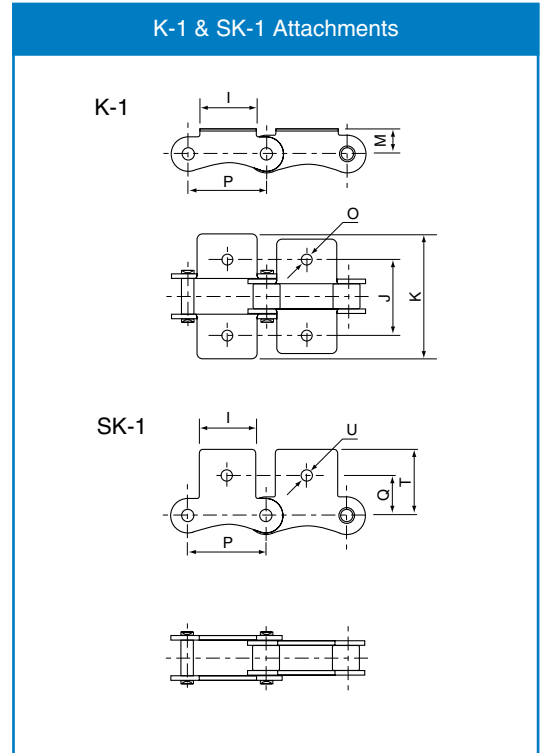

A-1, A-2 & K-1, K-2 Attachments

ISO Chain number	ANSI Chain number	P	I	R	J	K	M	O
C208B C208BL	C2040	25.40	19.10	9.50	25.40	39.60	9.10	3.40
	C2042	25.40	23.20	12.70	25.40	39.60	9.10	4.50
	C2050	31.75	23.80	11.90	31.80	49.00	11.10	5.50
	C2052	31.75	23.80	11.90	31.80	49.00	11.10	5.50
	C2060	38.10	28.60	14.30	42.90	67.80	14.70	5.50
	C2062	38.10	28.60	14.30	42.90	67.80	14.70	5.50
	C2060H	38.10	28.60	14.30	42.90	67.80	14.70	5.50
	C2062H	38.10	28.60	14.30	42.90	67.80	14.70	5.50
	C2080	50.80	38.10	19.10	55.60	87.80	19.10	6.80
	C2082	50.80	38.10	19.10	55.60	87.80	19.10	6.80
	C2080H	50.80	38.10	19.10	55.60	87.80	19.10	6.80
	C2082H	50.80	38.10	19.10	55.60	87.80	19.10	6.80
	C2100	63.50	47.60	23.80	66.60	107.50	23.40	9.20
	C2102	63.50	47.60	23.80	66.60	107.50	23.40	9.20
	C2100H	63.50	47.60	23.80	66.60	107.50	23.40	9.20
	C2102H	63.50	47.60	23.80	66.60	107.50	23.40	9.20
	C2120	76.20	57.20	28.60	79.30	121.40	27.80	11.00
	C2122	76.20	57.20	28.60	79.30	121.40	27.80	11.00
	C2120H	76.20	57.20	28.60	79.30	121.40	27.80	11.00
	C2122H	76.20	57.20	28.60	79.30	121.40	27.80	11.00
	C2160	101.60	76.20	38.10	104.70	151.60	36.50	13.10
	C2162	101.60	76.20	38.10	104.70	151.60	36.50	13.10
	C2160H	101.60	76.20	38.10	104.70	151.60	36.50	13.10
	C2162H	101.60	76.20	38.10	104.70	151.60	36.50	13.10

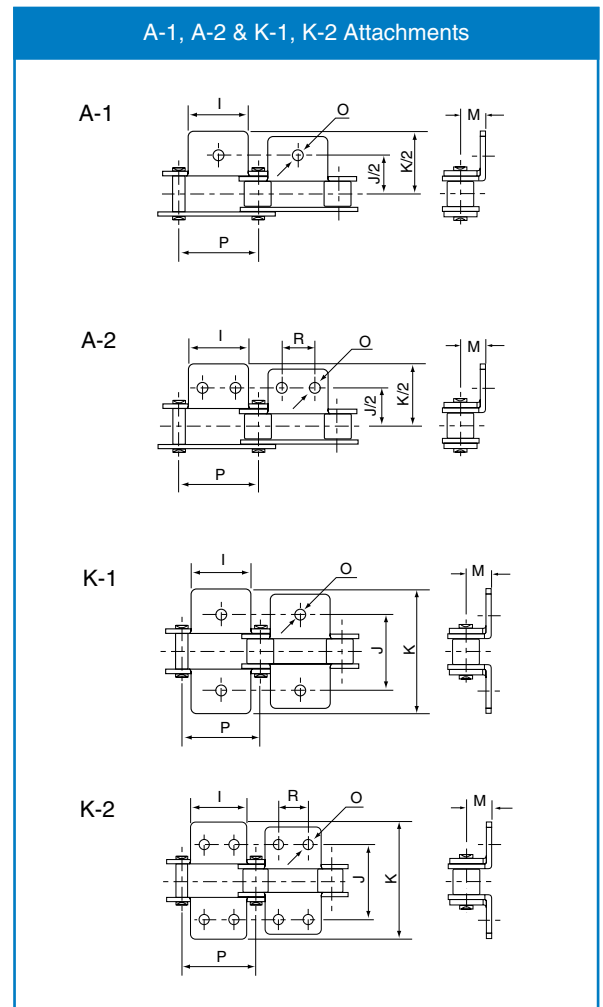

Every effort has been taken to ensure that the data listed in this catalogue is correct. Challenge accepts no liability for any inaccuracies or damage caused. All dimensions in millimetres unless otherwise stated.

Double Pitch Attachments

SA-1, SA-2 & SK-1, SK-2 Attachments

ISO Chain number	ANSI Chain number	P	I	R	Q ₁	Q ₂	J	O	U
	C2040 C2042	25.40	19.10	9.50	11.10	13.50	20.50	3.40	5.50
C208B C208BL		25.40	23.20	12.70	11.10	13.50	20.50	4.50	5.50
	C2050 C2052	31.75	23.80	11.90	14.30	15.90	25.00	5.50	6.60
	C2060 C2062	38.10	28.60	14.30	17.50	19.10	32.90	5.50	9.20
	C2060H C2062H	38.10	28.60	14.30	17.50	19.10	32.90	5.50	9.20
	C2080 C2082	50.80	38.10	19.10	22.20	25.40	43.50	6.60	11.00
	C2080H C2082H	50.80	38.10	19.10	22.20	25.40	43.50	6.60	11.00
	C2100 C2102	63.50	47.60	23.80	28.60	31.80	50.40	8.40	13.00
	C2100H C2102H	63.50	47.60	23.80	28.60	31.80	50.40	8.40	13.00

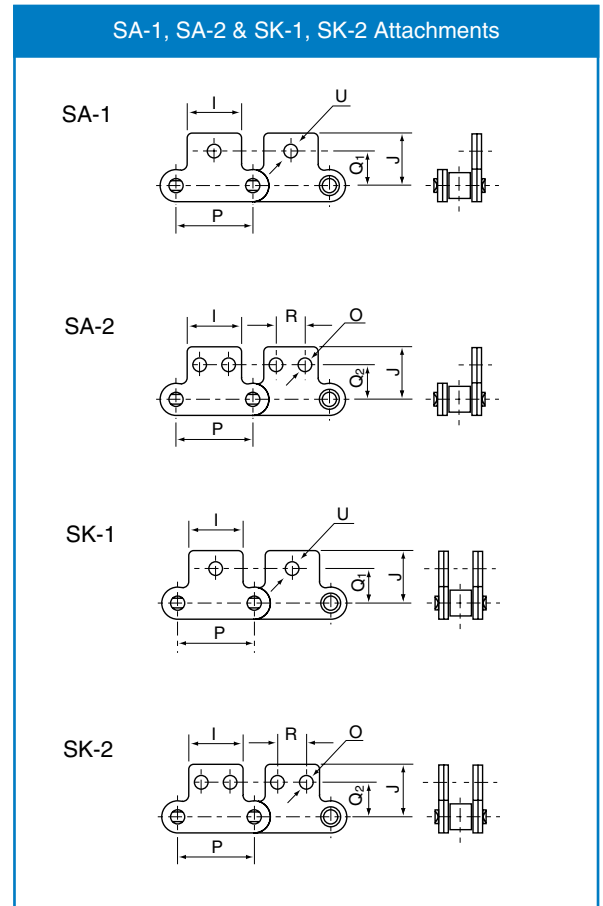

Special Chain (Attachment Holes in Side Plate)

ANSI Chain number	Pitch	Roller diameter	Width between inner plates	Pin diameter	Pin length	Side plate height	Side plate hole diameter
	P	A	B	C	D	F	V
C2040 C2042	25.40	7.95 15.88	7.85	3.96	16.60	12.00	4.10
C2050 C2052	31.75	10.16 19.05	9.40	5.08	20.70	15.00	5.10
C2060 C2062	38.10	11.91 22.23	12.57	5.94	25.90	18.00	6.10
C2060H C2062H	38.10	11.91 22.23	12.57	5.94	29.20	18.00	6.10
C2080 C2082	50.80	15.88 28.58	15.75	7.92	32.70	24.00	8.10
C2080H C2082H	50.80	15.88 28.58	15.75	7.92	36.20	24.00	8.10
C2100 C2102	63.50	19.05 39.67	18.90	9.53	40.40	30.00	10.10
C2100H C2102H	63.50	19.05 39.67	18.90	9.53	43.60	30.00	10.10

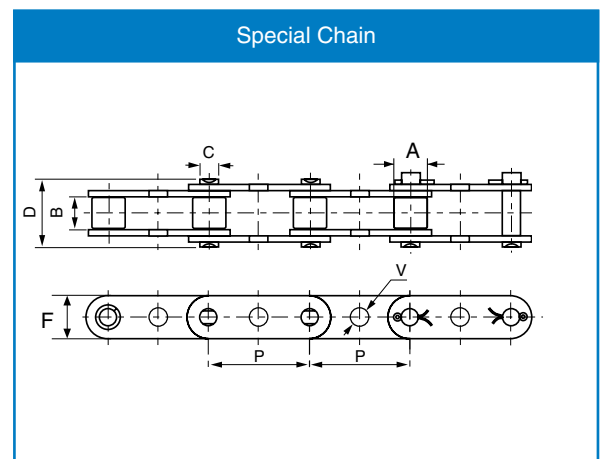

All dimensions in millimetres unless otherwise stated. Every effort has been taken to ensure that the data listed in this catalogue is correct. Challenge accepts no liability for any inaccuracies or damage caused.

Double Pitch Chain

Extended Pin Chain

ANSI Chain number	Pitch					
	P	B	C	S	D	E
C2040	25.40	7.85	3.96	9.50	25.10	26.20
C2042	25.40	7.85	3.96	9.50	25.10	26.20
C2050	31.75	9.40	5.08	11.90	31.30	33.10
C2052	31.75	9.40	5.08	11.90	31.30	33.10
C2060	38.10	12.57	5.94	14.30	38.60	40.60
C2062	38.10	12.57	5.94	14.30	38.60	40.60
C2060H	38.10	12.57	5.94	14.30	42.00	43.80
C2062H	38.10	12.57	5.94	14.30	42.00	43.80
C2080	50.80	15.75	7.92	19.10	50.30	53.30
C2082	50.80	15.75	7.92	19.10	50.30	53.30
C2080H	50.80	15.75	7.92	19.10	53.50	55.00
C2082H	50.80	15.75	7.92	19.10	53.50	55.00
C2100	63.50	18.90	9.53	23.80	61.80	66.10
C2102	63.50	18.90	9.53	23.80	61.80	66.10
C2100H	63.50	18.90	9.53	23.80	65.00	68.30
C2102H	63.50	18.90	9.53	23.80	65.00	68.30
C2120H	76.20	25.22	11.10	28.60	79.60	83.60
C2122H	76.20	25.22	11.10	28.60	79.60	83.60
C2160H	101.60	31.75	14.27	38.10	103.00	107.80
C2162H	101.60	31.75	14.27	38.10	103.00	107.80

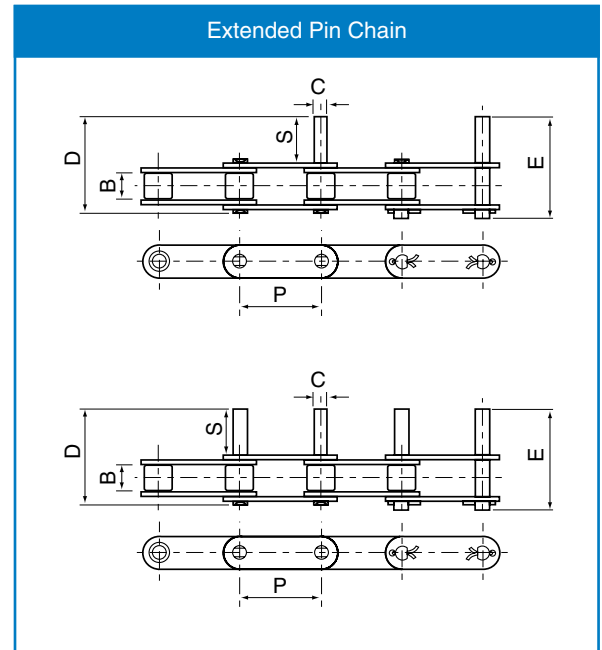

Extended Pin Chain

Chain number	Pitch						
	P	B	C	V	O	S	D
C2060H	38.10	12.57	5.94	5.94	8.00	25.00	53.00
C2060H	38.10	12.57	5.94	8.08	10.00	35.00	63.00
C2060H	38.10	12.57	5.94	5.94	12.70	41.20	69.20
C2060H	38.10	12.57	5.94	5.94	14.28	41.20	69.20

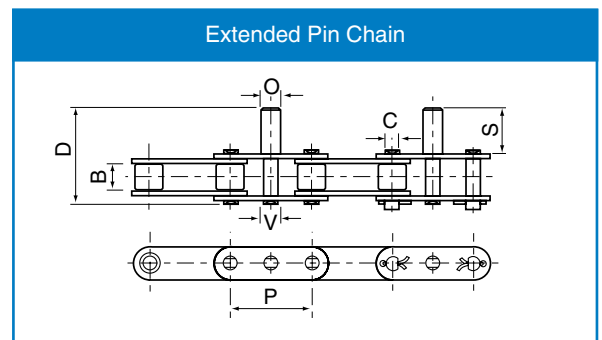

Hollow Pin Chain - Bushed Type (No Roller)

Chain number	Pitch	Roller diameter	Width between inner plates		Pin diameter		Pin length		Side plate height	Plate thickness	Minimum tensile strength	Average tensile strength	Weight	Type
			A	B	C	V	D	E						
C2040HP	25.400	7.95	7.85	5.63	4.00	16.5	17.6	12.00	1.50	11.00	12.6	0.46	B	
C2050HP	31.750	10.16	9.40	7.22	5.12	20.5	21.8	15.00	2.03	20.40	22.8	0.76	B	
02060HP	38.100	11.91	12.70	8.31	6.00	25.8	26.8	17.00	2.42	24.00	27.1	1.02	B	
C2080HP	50.800	15.88	15.75	11.40	8.05	32.5	33.8	24.00	3.25	50.00	55.2	1.81	B	

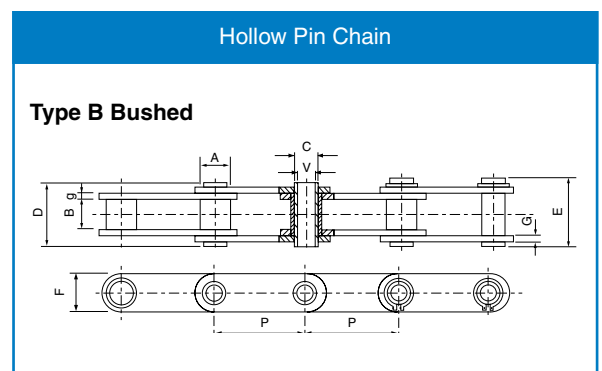

Every effort has been taken to ensure that the data listed in this catalogue is correct. Challenge accepts no liability for any inaccuracies or damage caused. All dimensions in millimetres unless otherwise stated.

Leaf Chain

LH / BL Series Leaf Chain

ANSI B29.8, ISO 4347, DIN 8152

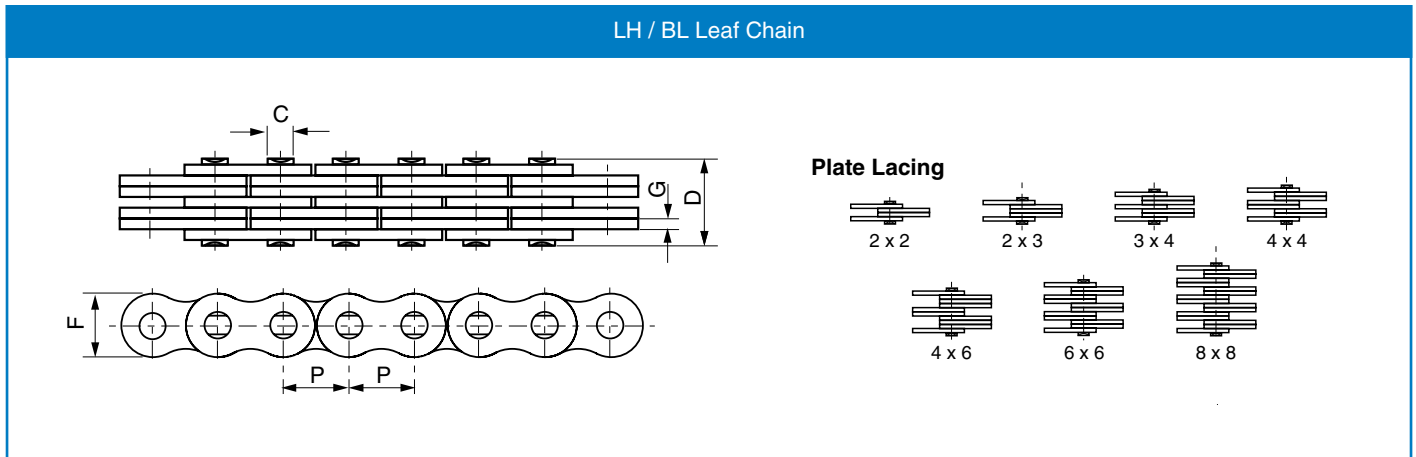

ISO Chain number	ANSI Chain number	Pitch P	Chain lacing	Plate height F	Plate thickness G	Pin diameter C	Pin length D	Minimum tensile strength kN	Average tensile strength kN	Weight kg/m
LH0822	BL422	12.700	2x2	12.07	2.08	5.09	11.05	22.20	27.60	0.64
LH0823	BL423		2x3				13.16	22.20	27.60	0.80
LH0834	BL434		3x4				17.40	33.40	41.40	1.12
LH0844	BL444		4x4				19.51	44.50	56.00	1.28
LH0846	BL446		4x6				23.75	44.50	56.00	1.60
LH0866	BL466		6x6				27.99	66.70	81.70	1.92
LH0888	BL488		8x8				36.45	89.00	109.40	2.56
LH1022	BL522		15.875				2x2	15.09	2.44	5.96
LH1023	BL523	2x3		15.37	33.40	43.10	1.10			
LH1034	BL534	3x4		20.32	48.90	65.60	1.50			
LH1044	BL544	4x4		22.78	66.70	84.50	1.80			
LH1046	BL546	4x6		27.74	66.70	84.50	2.20			
LH1066	BL566	6x6		32.69	100.10	125.10	2.65			
LH1088	BL588	8x8		42.57	133.40	169.50	3.50			
LH1222	BL622	19.050		2x2	18.11	3.30	7.94			
LH1223	BL623		2x3	20.73				48.90	63.60	1.80
LH1234	BL634		3x4	27.43				75.60	102.80	2.50
LH1244	BL644		4x4	30.78				97.90	120.90	2.90
LH1246	BL646		4x6	37.49				97.90	120.90	3.60
LH1266	BL666		6x6	44.20				146.80	190.80	4.30
LH1288	BL688		8x8	57.61				195.70	238.80	5.80
LH1622	BL822		25.400	2x2				24.13	4.09	9.54
LH1623	BL823	2x3		25.48	84.50	108.20	2.70			
LH1634	BL834	3x4		33.76	129.00	170.00	3.80			
LH1644	BL844	4x4		37.90	169.00	214.60	4.30			
LH1646	BL846	4x6		46.18	169.00	214.60	5.40			
LH1666	BL866	6x6		54.46	253.60	324.50	6.50			
LH1688	BL888	8x8		71.02	338.10	432.70	8.60			

All dimensions in millimetres unless otherwise stated. Every effort has been taken to ensure that the data listed in this catalogue is correct. Challenge accepts no liability for any inaccuracies or damage caused.

Leaf Chain

LH / BL Series Leaf Chain (cont)

ANSI B29.8, ISO 4347, DIN 8152

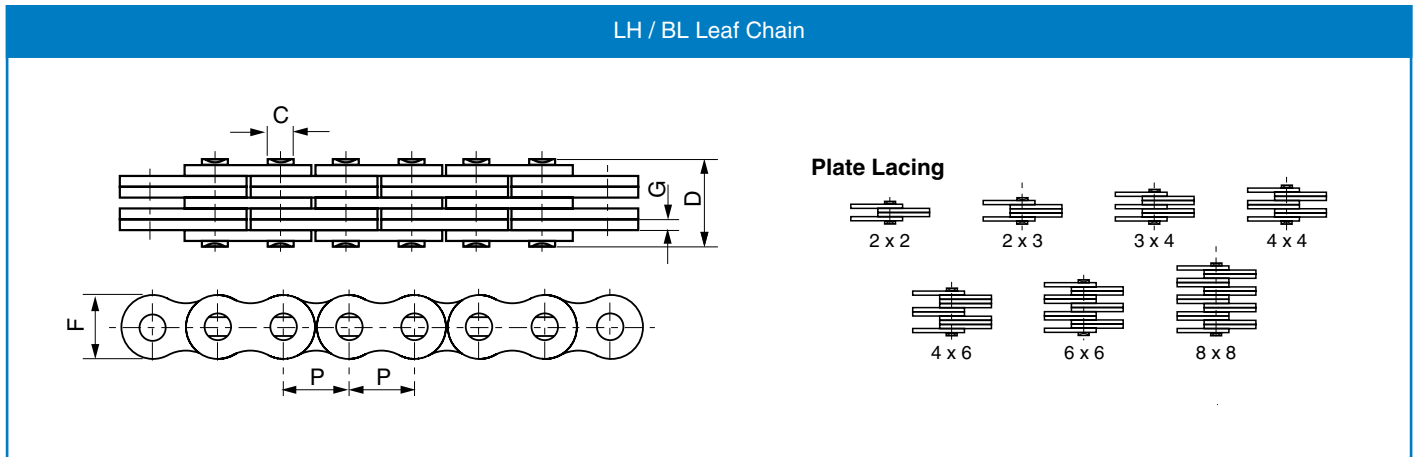

ISO Chain number	ANSI Chain number	Pitch P	Chain lacing	Plate height F	Plate thickness G	Pin diameter C	Pin length D	Minimum tensile strength kN	Average tensile strength kN	Weight kg/m
LH2022	BL1022	31.750	2x2	30.18	4.90	11.11	25.37	115.60	150.80	3.40
LH2023	BL1023		2x3				30.33	115.60	150.80	4.30
LH2034	BL1034		3x4				40.23	182.40	231.60	6.00
LH2044	BL1044		4x4				45.19	231.30	291.40	6.90
LH2046	BL1046		4x6				55.09	231.30	291.40	8.60
LH2066	BL1066		6x6				65.00	347.00	430.30	10.30
LH2088	BL1088	8x8	84.81	462.60	555.10	13.80				
LH2422	BL1222	38.100	2x2	36.20	5.77	12.71	29.62	151.20	192.00	4.60
LH2423	BL1223		2x3				35.43	151.20	192.00	5.80
LH2434	BL1234		3x4				47.07	244.60	315.90	8.10
LH2444	BL1244		4x4				52.88	302.50	381.10	9.30
LH2446	BL1246		4x6				64.52	302.50	381.10	11.60
LH2466	BL1266		6x6				76.15	453.70	543.60	13.90
LH2488	BL1288	8x8	99.42	605.00	726.00	18.60				
LH2822	BL1422	44.450	2x2	42.24	6.55	14.29	33.55	191.30	225.70	6.10
LH2823	BL1423		2x3				40.16	191.30	225.70	7.60
LH2834	BL1434		3x4				53.37	315.80	372.60	10.60
LH2844	BL1444		4x4				59.97	382.60	451.20	12.20
LH2846	BL1446		4x6				73.18	382.60	451.20	15.20
LH2866	BL1466		6x6				86.39	578.30	682.40	18.20
LH2888	BL1488	8x8	112.80	765.10	902.80	24.30				
LH3222	BL1622	50.800	2x2	48.26	7.52	17.46	39.01	289.10	341.10	8.00
LH3223	BL1623		2x3				46.58	289.10	341.10	10.00
LH3234	BL1634		3x4				61.72	440.40	519.60	14.00
LH3244	BL1644		4x4				69.29	578.30	680.40	16.00
LH3246	BL1646		4x6				84.43	578.30	680.40	20.00
LH3266	BL1666		6x6				99.57	857.40	1000.70	24.00
LH3288	BL1688	8x8	129.84	1156.50	1364.60	32.00				
LH4022	BL2022	63.500	2x2	60.33	9.91	23.81	51.74	433.70	511.70	15.80
LH4023	BL2023		2x3				61.70	433.70	511.70	19.80
LH4034	BL2034		3x4				81.61	649.40	766.20	27.70
LH4044	BL2044		4x4				91.57	867.40	1023.50	31.60
LH4046	BL2046		4x6				111.48	867.40	1023.50	39.50
LH4066	BL2066		6x6				131.39	1301.10	1535.20	47.40
LH4088	BL2088	8x8	171.22	1734.80	2046.50	63.20				

Leaf Chain

LL/EL Series Leaf Chain

ANSI B29.8-1958, ISO 4347

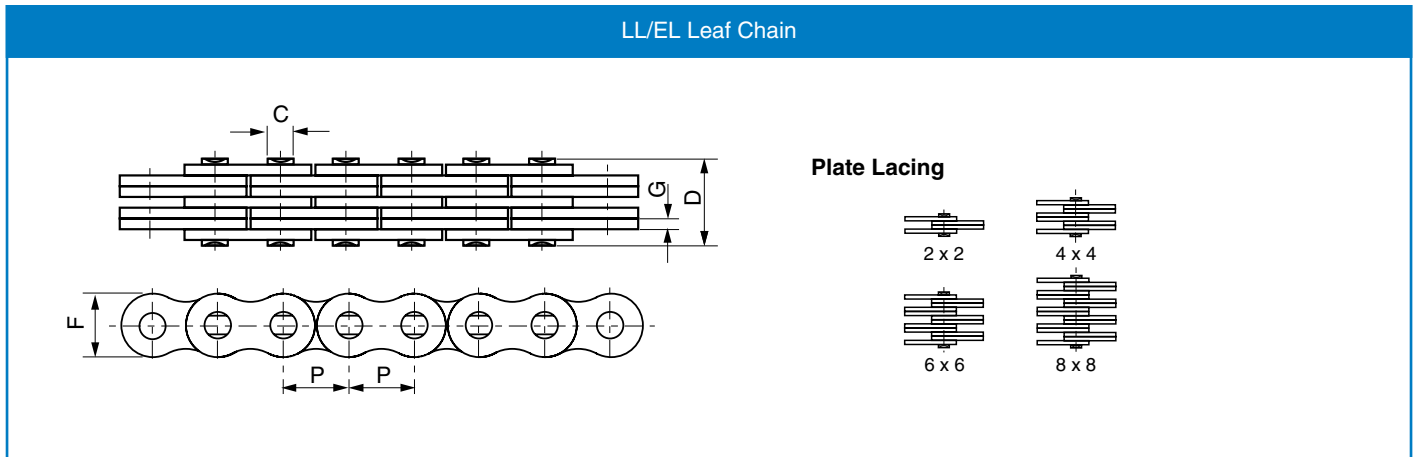

ISO Chain number	ANSI Chain number	Pitch P	Chain lacing	Plate height F	Plate thick- G	Pin diameter C	Pin length strength D	Minimum tensile strength kN	Average tensile metre kN	Weight kg/m
LL0822	EL0422	12.700	2x2	10.60	1.30	4.45	7.60	17.80	20.40	0.35
LL0844	EL0444		4x4				13.00	31.10	35.70	0.69
LL0866	EL0466		6x6				18.20	44.50	50.90	1.00
LL0888	EL0488		8x8				23.50	62.20	71.20	1.33
LL1022	EL0522	15.875	2x2	13.70	1.60	5.08	9.20	22.30	25.50	0.54
LL1044	EL0544		4x4				15.80	44.50	51.00	1.06
LL1066	EL0566		6x6				22.10	66.70	76.30	1.57
LL1088	EL0588		8x8				28.80	89.00	101.90	2.10
LL1222	EL0622	19.050	2x2	16.00	1.85	5.72	10.40	28.90	33.20	0.73
LL1244	EL0644		4x4				17.90	57.80	66.40	1.44
LL1266	EL0666		6x6				25.40	86.70	99.70	2.15
LL1288	EL0688		8x8				32.90	115.60	132.90	2.84
LL1622	EL0822	25.400	2x2	21.00	3.10	8.28	17.20	58.00	66.70	1.52
LL1644	EL0844		4x4				29.60	144.00	164.60	2.90
LL1666	EL0866		6x6				42.40	200.00	230.00	4.30
LL1688	EL0888		8x8				55.40	288.00	331.20	5.71
LL2022	EL1022	31.750	2x2	26.40	3.70	10.19	20.10	95.00	109.20	2.33
LL2044	EL1044		4x4				33.80	190.00	218.50	4.40
LL2066	EL1066		6x6				50.10	285.00	324.60	6.79
LL2088	EL1088		8x8				65.40	380.00	435.10	8.75
LL2422	EL1222	38.100	2x2	33.40	5.00	14.63	28.40	170.00	195.50	4.47
LL2444	EL1244		4x4				46.30	340.00	380.80	8.22
LL2466	EL1266		6x6				66.40	510.00	571.20	12.22
LL2488	EL1288		8x8				86.60	680.00	775.20	16.30
LL2822	EL1422	44.450	2x2	37.08	6.00	15.90	32.20	200.00	224.00	5.10
LL2844	EL1444		4x4				56.40	400.00	448.00	9.90
LL2866	EL1466		6x6				80.60	600.00	672.00	14.60
LL2888	EL1488		8x8				105.20	800.00	896.00	19.40
LL3222	EL1622	50.800	2x2	42.00	6.00	17.81	33.20	260.00	291.20	5.80
LL3244	EL1644		4x4				57.40	520.00	582.40	11.40
LL3266	EL1666		6x6				81.60	780.00	873.60	16.90
LL3288	EL1688		8x8				105.00	1050.00	1176.00	24.00
LL4022	EL2022	63.500	2x2	52.76	8.25	22.89	44.70	360.00	403.20	10.30
LL4044	EL2044		4x4				77.90	780.00	873.60	20.00
LL4066	EL2066		6x6				111.10	1080.00	1209.60	29.50
LL4088	EL2088		8x8				145.50	1560.00	1747.20	39.10
LL4822	EL2422	76.200	2x2	63.88	10.30	29.24	56.10	560.00	627.20	18.50
LL4844	EL2444		4x4				97.40	1120.00	1554.40	35.70
LL4866	EL2466		6x6				138.90	1168.00	1308.10	53.00
LL4888	EL2488		8x8				182.40	2240.00	2508.80	70.40

All dimensions in millimetres unless otherwise stated. Every effort has been taken to ensure that the data listed in this catalogue is correct. Challenge accepts no liability for any inaccuracies or damage caused.

Leaf Chain

AL Series Leaf Chain

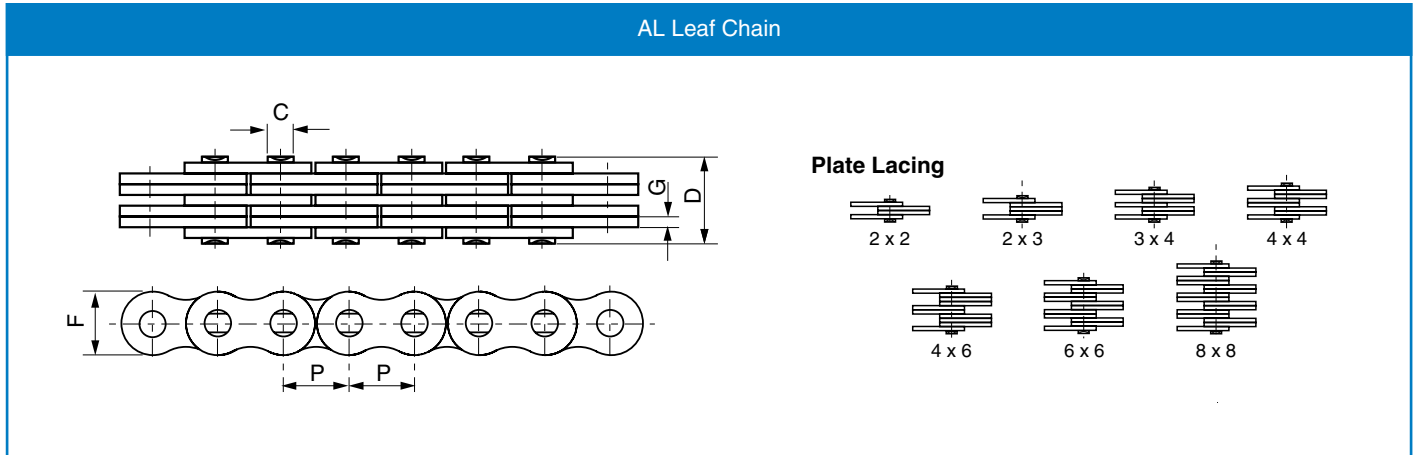

ANSI Chain number	Pitch P	Chain lacing	Plate height F	Plate thickness G	Pin diameter C	Pin length D	Minimum tensile strength kN	Average tensile strength kN	Weight kg/m
AL322	9.525	2x2	7.70	1.30	3.58	6.80	9.00	10.20	0.23
AL422		2x2				7.90	14.10	16.90	0.39
AL444	12.700	4x4	10.40	1.50	3.96	14.40	28.20	35.20	0.74
AL466		6x6				20.50	42.30	52.70	1.10
AL522		2x2				10.30	22.00	27.50	0.61
AL534	15.875	3x4	12.80	2.03	5.08	17.00	33.00	46.00	1.10
AL544		4x4				18.90	44.00	55.00	1.19
AL566		6x6				26.90	66.00	82.50	1.79
AL622		2x2				12.40	37.00	44.40	0.86
AL644	19.050	4x4	15.60	2.42	5.94	22.70	64.00	78.80	1.69
AL666		6x6				32.40	101.00	118.60	2.52
AL822		2x2				16.00	56.70	68.60	1.54
AL844	25.400	4x4	20.50	3.25	7.92	29.40	113.40	135.60	3.00
AL866		6x6				42.50	170.00	202.30	4.46
AL1022		2x2				19.60	88.50	107.10	2.37
AL1044	31.750	4x4	25.60	4.00	9.53	35.90	177.00	203.60	4.68
AL1066		6x6				52.30	265.00	315.30	7.00
AL1222		2x2				24.30	127.00	151.10	3.65
AL1244	38.100	4x4	30.50	4.80	11.10	43.80	254.00	299.70	7.05
AL1266		6x6				63.00	381.00	426.30	10.44
AL1444	44.450	4x4	36.40	5.60	12.64	51.30	372.70	413.60	10.34
AL1466		6x6				74.56	559.00	620.40	15.16
AL1644	50.800	4x4	41.60	6.40	14.21	58.06	471.00	522.80	12.98
AL1666		6x6				84.46	706.00	783.60	19.41

Leaf Chain

FLC Series Leaf Chain

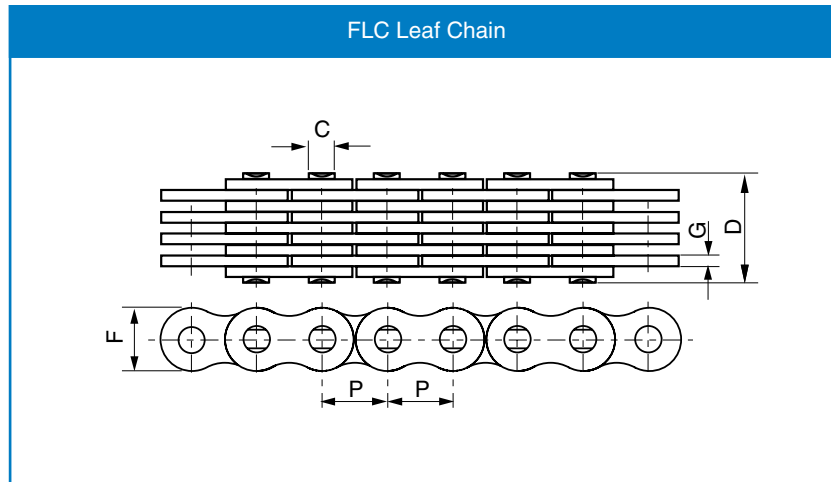

Chain number	Pitch P	Chain lacing	Plate height F	Plate thickness G	Pin diameter C	Pin length D	Minimum tensile strength kN	Average tensile strength kN	Weight kg/m
FL644	19.050	4x4	4.70	0.60	1.85	6.60	6.50	7.80	0.13
FL666	19.050	6x6	4.70	0.60	1.85	9.30	9.75	11.80	0.20
FL688	19.050	8x8	4.70	0.60	1.85	12.00	13.00	15.60	0.25
FL844	25.400	4x4	6.90	0.73	2.31	7.90	10.00	12.10	0.25
FL944	9.525	4x4	8.70	1.04	3.28	10.40	21.00	24.70	0.43
FL966	9.525	6x6	8.70	1.00	3.28	14.90	31.00	36.80	0.65
F1222	38.100	2x2	8.20	1.00	3.58	7.00	11.43	13.60	0.19
F1223	38.100	2x3	10.20	2.03	4.45	12.80	20.00	23.80	0.61
F1244	38.100	4x4	10.20	1.70	4.45	16.70	44.00	52.30	0.83

All dimensions in millimetres unless otherwise stated. Every effort has been taken to ensure that the data listed in this catalogue is correct. Challenge accepts no liability for any inaccuracies or damage caused.

Leaf Chain

Clevis Pins

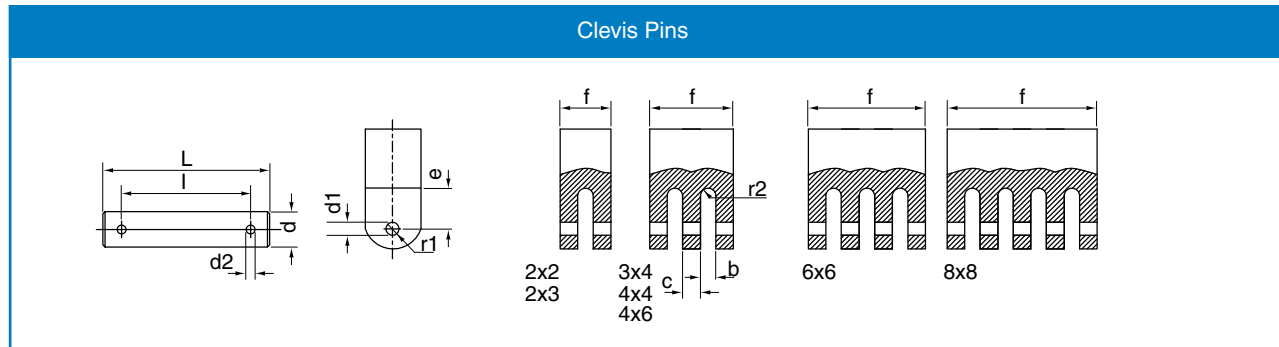

Type	l min.	L max	d max	d2	f max	b min	c max	d1	e min	r1 max	r2 max
BL422/AL522	10.8	17.0			10.7	4.2	-				2
BL423	12.7	18.9			12.6	6.4	-				3
BL434	17.0	23.2	5.80	1.6	16.9	4.2	2.0				2
BL444/AL544	19.0	25.2	5.80	1.6	18.9	4.2	4.0	5.15	9.0	6.5	2
BL446	23.0	29.2	5.80	1.6	22.9	6.4	4.0	5.15	9.0	6.5	3
BL466/AL566	27.0	33.3	5.80	1.6	26.9	4.2	4.0	5.15	9.0	6.5	2
BL488/AL588	35.5	41.8	5.80	1.6	35.4	4.2	4.0	5.15	9.0	6.5	2
BL522	12.8	19.4	5.95	2.0	12.7	5.0	-				2
BL523	15.0	21.6	5.95	2.0	14.9	7.5	-				3
BL534	20.0	26.6	5.95	2.0	19.9	5.0	2.4				2
BL544/AL644	22.5	29.1	5.95	2.0	22.4	5.0	4.8	6.00	11.0	8.0	2
BL546	27.0	33.7	5.95	2.0	26.9	7.5	4.8	6.00	11.0	8.0	3
BL566/AL666	32.0	38.7	5.95	2.0	31.9	5.0	4.8	6.00	11.0	8.0	2
BL588/AL688	42.5	49.3	5.95	2.0	42.4	5.0	4.8	6.00	11.0	8.0	2
BL623	20.0	30.7	7.93	3.2	19.9	10.3	-				5
BL634	27.0	37.7	7.93	3.2	26.9	6.8	3.2				3
BL644/AL844	30.0	40.7	7.93	3.2	29.9	6.8	6.4	8.00	14.0	9.5	3
BL646	37.0	47.7	7.93	3.2	36.9	10.3	6.4	8.00	14.0	9.5	5
BL666/AL866	43.0	53.7	7.93	3.2	42.9	6.8	6.4	8.00	14.0	9.5	3
BL688	56.5	67.2	7.93	3.2	56.4	6.8	6.4	8.00	14.0	9.5	3
BL823	25.0	35.7	9.52	3.2	24.9	12.8	-				6
BL834	33.0	43.7	9.52	3.2	32.9	8.5	4.0				4
BL844/AL1044	37.0	47.7	9.52	3.2	36.9	8.5	8.0	9.60	18.0	12.5	4
BL846	46.0	56.7	9.52	3.2	45.9	12.8	8.0	9.60	18.0	12.5	6
BL866/AL1066	53.0	63.7	9.52	3.2	52.9	8.5	8.0	9.60	18.0	12.5	4
BL888/AL1088	69.5	80.3	9.52	3.2	69.4	8.5	8.0	9.60	18.0	12.5	4
BL1023	30.0	42.4	11.09	4.0	29.8	15.1	-				7
BL1034	39.2	51.6	11.09	4.0	39.0	10.0	4.7				5
BL1044/AL1244	44.2	56.6	11.09	4.0	44.0	10.0	9.4	11.20	22.0	15.0	5
BL1046	54.2	66.6	11.09	4.0	54.0	15.1	9.4	11.20	22.0	15.0	7
BL1066/AL1266	63.2	75.6	11.09	4.0	63.0	10.0	9.4	11.20	22.0	15.0	5
BL1088/AL1288	79.9	92.4	11.09	4.0	79.7	10.0	9.4	11.20	22.0	15.0	5
BL1223	34.5	46.9	12.70	4.0	34.3	17.7	-				8
BL1234	46.2	58.6	12.70	4.0	46.0	11.8	5.5				5
BL1244/AL1444	50.0	64.4	12.70	4.0	49.0	11.8	11.0	12.80	26.0	19.0	5
BL1246	63.5	76.0	12.70	4.0	63.3	17.7	11.0	12.80	26.0	19.0	8
BL1266/AL1466	75.3	87.8	12.70	4.0	75.1	11.8	11.0	12.80	26.0	19.0	5
BL1288/AL1488	98.6	111.1	12.70	4.0	98.4	11.8	11.0	12.80	26.0	19.0	5
BL1423	38.7	51.1	14.27	4.0	38.5	20.1	-				10
BL1434	52.2	64.6	14.27	4.0	52.0	13.4	6.3				6
BL1444	58.6	71.1	14.27	4.0	58.4	13.4	12.6	14.35	31.0	22.0	10
BL1446	71.7	84.2	14.27	4.0	71.5	20.1	12.6	14.35	31.0	22.0	10
BL1466	85.1	97.7	14.27	4.0	84.9	13.4	12.6	14.35	31.0	22.0	10
BL1623	43.1	60.6	17.46	5.0	42.8	22.5	-				10
BL1634	58.0	75.5	17.46	5.0	57.7	15.0	7.1				7
BL1644	65.7	82.9	17.46	5.0	65.4	15.0	14.2	17.50	34.0	25.0	7
BL1646	79.9	97.4	17.46	5.0	79.6	22.5	14.2	17.50	34.0	25.0	10
BL1666	94.6	112.2	17.46	5.0	94.3	15.0	14.2	17.50	34.0	25.0	7
BL1688	124.0	141.6	17.46	5.0	123.7	15.0	14.2	17.50	34.0	25.0	7

Every effort has been taken to ensure that the data listed in this catalogue is correct. Challenge accepts no liability for any inaccuracies or damage caused. All dimensions in millimetres unless otherwise stated.

Leaf Chain

Leaf Chain with Extended Pin

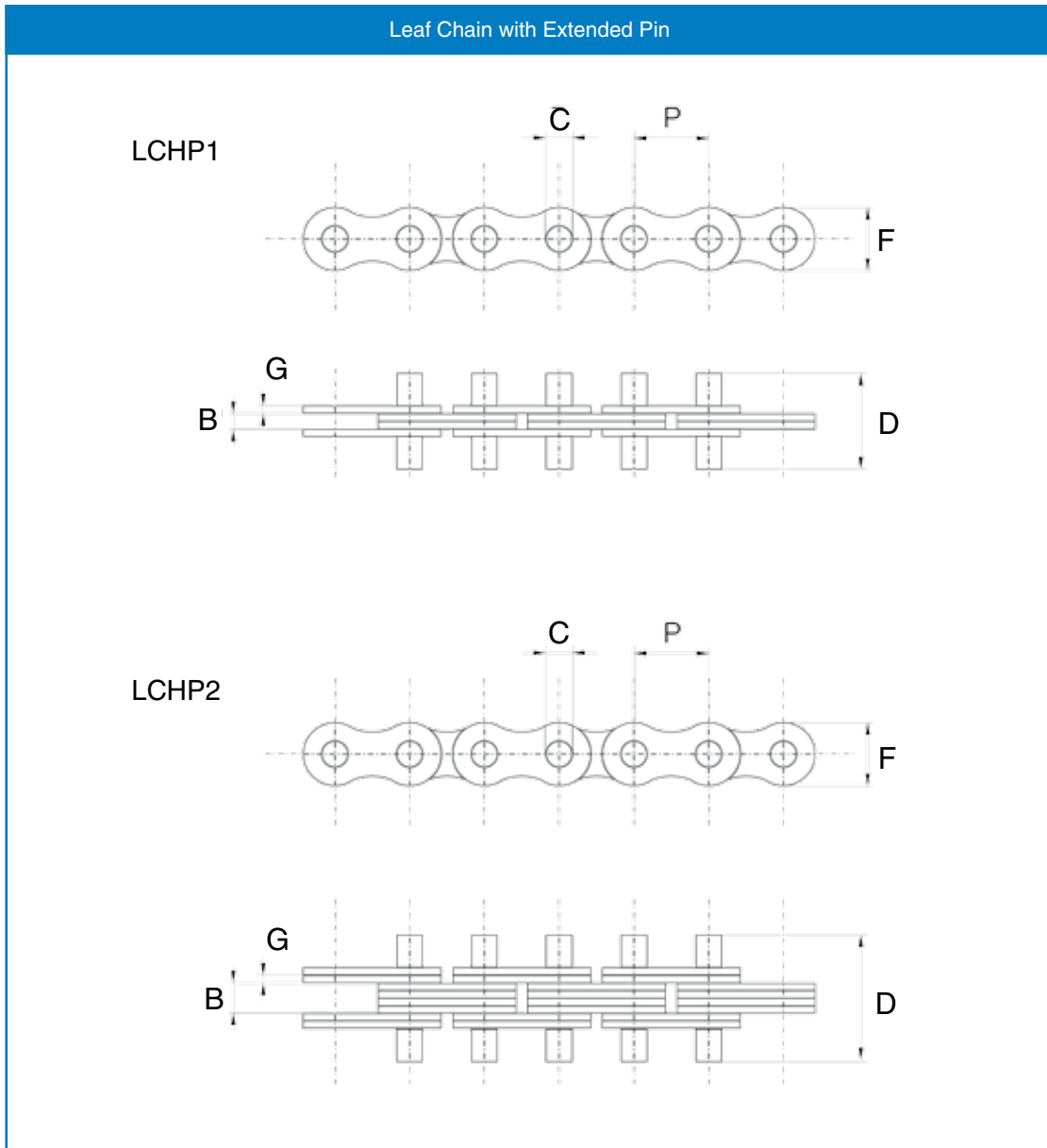

Chain number	Pitch	Width between inner plates	Plate thickness	Pin diameter	Pin length	Plate height	Tensile strength	Weight
	P	B	G	C	D	F	kN	kg/m
LCHP1	19.050	3.75	1.80	5.52	18.7	1.3	29.5	1.48
LCHP2	15.875	6.20	1.45	5.08	29.0	1.3	44.5	0.96

All dimensions in millimetres unless otherwise stated. Every effort has been taken to ensure that the data listed in this catalogue is correct. Challenge accepts no liability for any inaccuracies or damage caused.

Timber Chain

Welded Steel Chain (Offset Side Bar)

Chain number	Pitch		Average Ultimate Strength lbf	Max. Working Load lbf	Links Per Foot	Average Weight		Dimensions					
	mm	Inches				lb/ft	CE	X	D	T	F	H	A
WR78	66.26	2.609	24000	3000	4.6	4.0	76.20	50.80	12.70	6.35	28.58	22.23	28.58
WH78	66.26	2.609	36000	3500	4.6	4.0	76.20	50.80	12.70	6.35	28.58	22.23	28.58
WR82	78.10	3.074	30000	5000	3.9	5.0	79.50	57.00	14.29	6.40	31.80	25.40	32.00
WH82	78.10	3.074	40000	6650	3.9	5.2	79.50	57.00	14.29	6.40	31.80	27.00	32.00
WR124	101.60	4.000	46000	6300	3.0	8.3	107.95	69.85	19.05	9.53	38.10	31.75	38.10
WH124	101.60	4.000	60000	7350	3.0	8.3	107.95	69.85	19.05	9.53	38.10	31.75	38.10
WR111	120.90	4.760	46000	7550	2.5	9.5	123.83	85.00	19.05	9.53	44.45	31.75	50.80
WH111	120.90	4.760	60000	8850	2.5	9.5	123.83	85.00	19.05	9.53	44.45	31.75	50.80
WR106	152.40	6.000	46000	6750	2.0	7.0	107.95	69.85	19.05	9.53	38.10	31.75	41.28
WH106	152.40	6.000	69000	7200	2.0	7.0	107.95	69.85	19.05	9.53	38.10	31.75	41.28
WR110	152.40	6.000	46000	6750	2.0	7.2	117.48	76.20	19.05	9.53	38.10	31.75	47.63
WH110	152.40	6.000	69000	7900	2.0	7.2	117.48	76.20	19.05	9.53	38.10	31.75	47.63
WR132	153.67	6.050	84000	13100	2.0	14.2	158.75	111.00	25.40	12.70	50.80	41.28	73.03
WH132	153.67	6.050	110000	15000	2.0	14.2	158.75	111.00	25.40	12.70	50.80	41.28	73.03
WR150	153.67	6.050	84000	13100	2.0	16.8	158.75	111.00	25.40	12.70	63.50	41.28	73.03
WH150	153.67	6.050	110000	15300	2.0	16.8	158.75	111.00	25.40	12.70	63.50	41.28	73.03

WR - Welded steel chain with through-hardened pins

WH - Welded steel chain - fully heat treated

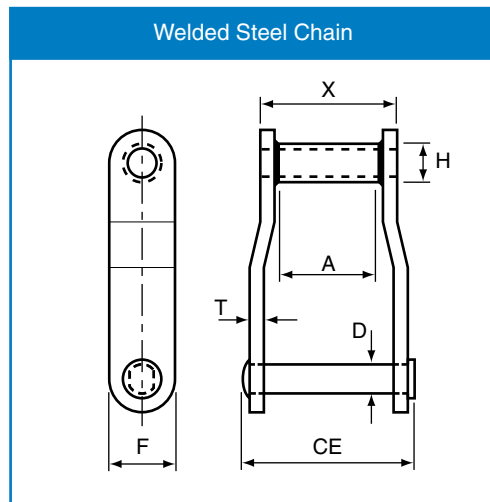

Timber Chain

Welded Steel Chain Attachments (Offset Side Bar)

Attachment number	Chain number	Weight lb/ft	Dimensions												
			A	D	E	F	G	H	K	M	R	T	X	Y	Z
A1	WR/WH78	4.97	50.80	9.58	31.75	12.70	20.57	31.75	-	-	14.27	6.35	-	-	-
A1	WR/WH82	6.50	54.10	9.58	44.45	15.88	23.88	38.10	-	-	15.88	6.35	-	-	-
A1	WR/WH124	8.40	66.68	15.88	50.80	15.88	28.70	45.97	-	-	19.05	9.53	-	-	-
A2	WR/WH78	4.50	50.80	9.58	54.10	12.70	19.81	10.41	-	28.70	14.27	6.35	-	-	-
A2	WR/WH82	6.00	54.10	9.53	57.15	15.80	23.88	12.70	-	31.75	15.88	7.92	-	-	-
A2	WR/WH124	10.00	66.68	9.58	76.20	22.23	28.70	22.23	-	49.28	19.05	9.53	-	-	-
A2	WR/WH132	17.00	95.25	12.70	101.60	19.05	38.10	41.28	-	69.85	25.40	12.70	-	-	-
A225	WR/WH124	8.90	101.60	-	50.80	49.28	-	50.80	-	-	19.05	12.70	-	57.15	22.23
F10	WR/WH82	4.80	-	-	31.75	-	-	23.80	-	-	15.88	6.35	260.35	-	-
F30	WR/WH78	9.90	-	-	25.40	-	68.33	20.57	-	-	14.27	54.10	76.20	-	-
F659	WR/WH124	13.10	-	-	44.45	-	120.65	12.70	-	-	19.05	-	167.39	-	-

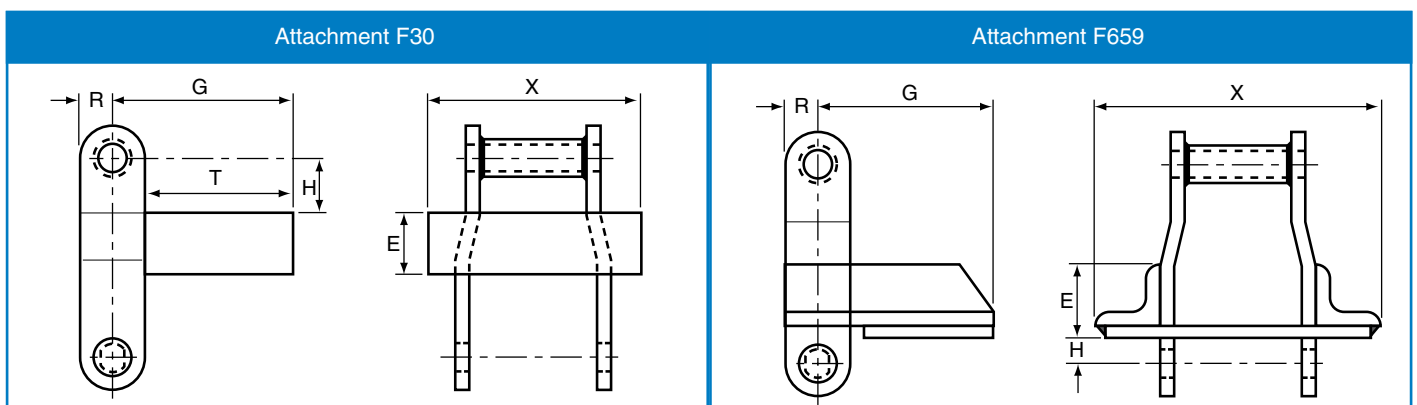
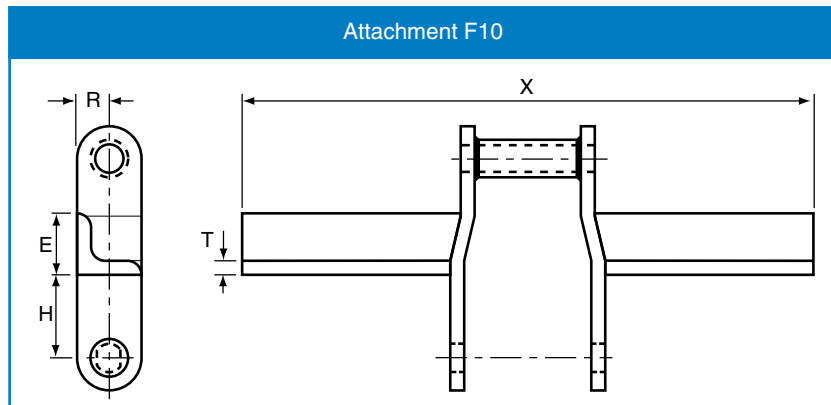
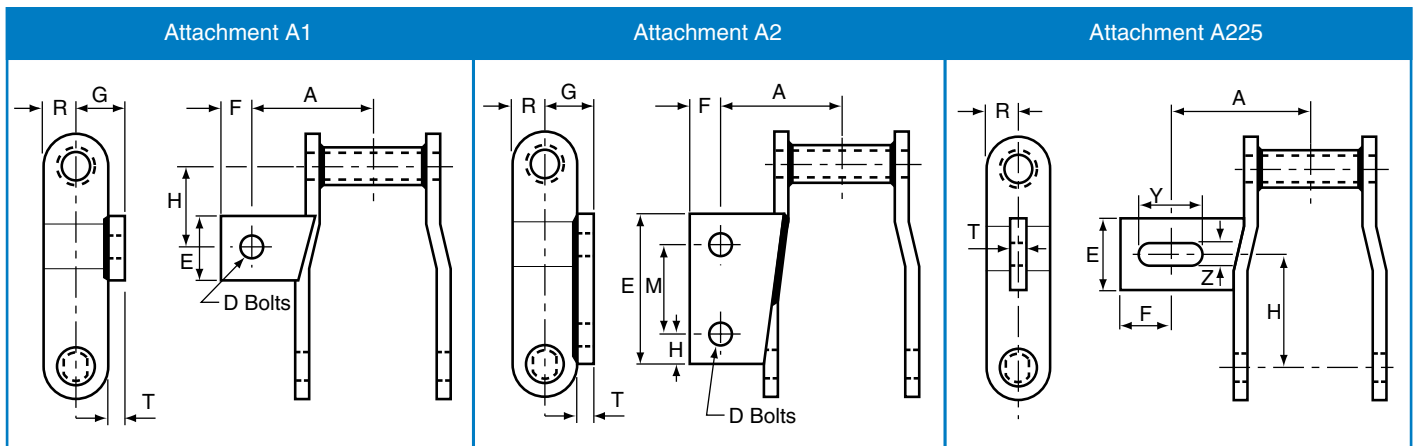

All dimensions in millimetres unless otherwise stated. Every effort has been taken to ensure that the data listed in this catalogue is correct. Challenge accepts no liability for any inaccuracies or damage caused.

Timber Chain

Welded Steel Chain Attachments (Offset Side Bar)

Attachment number	Chain number	Weight lb/ft	Dimensions												
			A	D	E	F	G	H	K	M	R	T	X	Y	Z
H2	WR/WH78	4.75	-	-	-	-	90.42	7.87	25.40	-	14.22	6.35	-	-	-
H2	WR/WH82	9.00	-	-	-	-	91.95	15.75	28.70	-	15.75	4.83	-	-	-
K1	WR/WH78	4.97	50.80	9.65	31.75	12.70	20.57	31.75	-	-	14.22	6.35	-	-	-
K1	WR/WH82	6.50	54.10	9.65	44.45	15.75	23.88	38.10	-	-	15.75	6.35	-	-	-
K1	WR/WH124	11.70	66.55	15.75	50.80	15.75	28.70	45.97	-	-	19.05	9.65	-	-	-
K2	WR/WH78	5.00	50.80	9.65	54.10	12.70	19.81	10.41	-	28.70	14.22	6.35	-	-	-
K2	WR/WH82	8.00	54.10	9.65	57.15	15.75	23.88	12.70	-	31.75	15.75	7.87	-	-	-
K2	WR/WH124	12.00	66.55	9.65	76.20	22.35	28.70	22.35	-	49.28	19.05	9.65	-	-	-
K2	WR/WH132	19.00	95.25	12.70	101.60	19.05	38.10	41.15	-	69.85	25.40	12.70	-	-	-
RR	WR/WH78	4.70	-	-	-	-	38.10	19.05	-	-	14.22	6.35	-	-	-
RR	WR/WH82	7.00	-	-	-	-	44.45	20.57	-	-	15.75	6.35	-	-	-
RR	WR/WH124	10.00	-	-	-	-	47.75	38.10	-	-	19.05	9.65	-	-	-

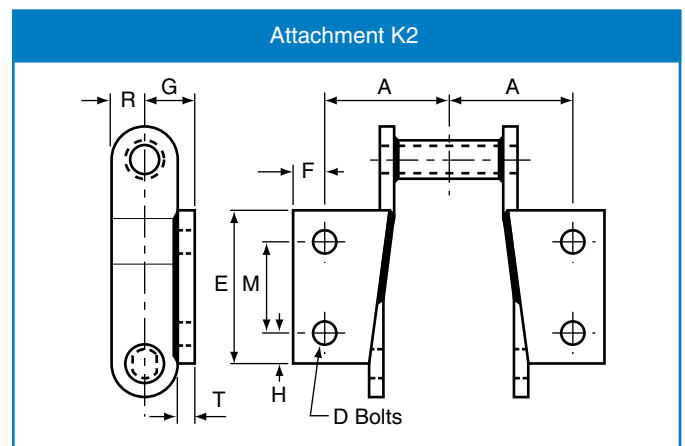
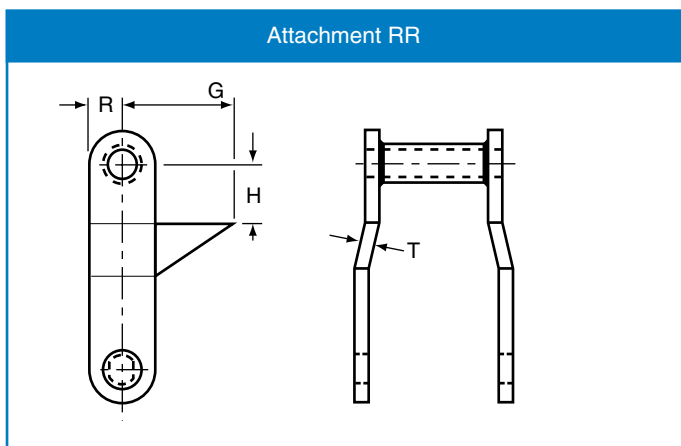
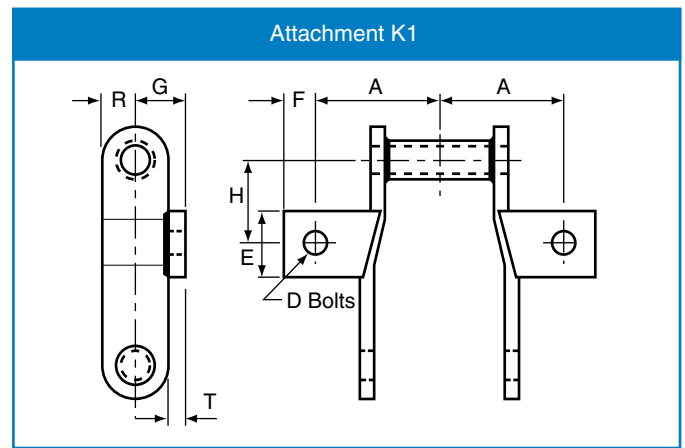
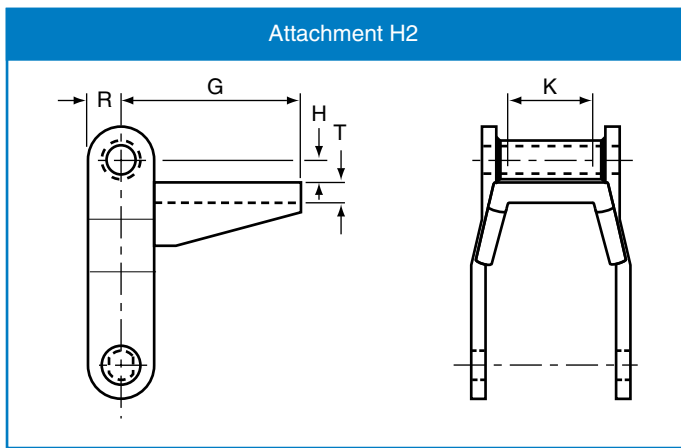

Timber Chain

Offset Side Bar Roller Chain

Offset Side Bar Roller Chain

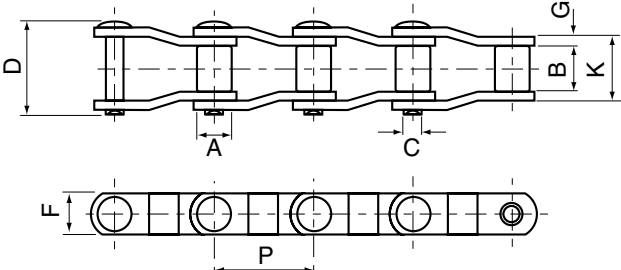

Material Spec.				
	Side Bar	Pin	Bushing	Roller
S0-578	CH	CH	CC	CC
M0-88	C	CH	CC	CC
LXS-882	CH	AH	AC	CH
M0H-578	CH	CH	CC	CH

Chain number	Pitch		Average Ultimate Strength lbf	Max. Working Load lbf	Links Per Foot	Average Weight lb/ft	Dimensions						
	inch	mm					A	B	C	D	F	G	K
S0-578	2.609	66.269	19,000	2,200	4.6	2.7	22.23	26.99	9.53	52.78	25.40	3.97	36.51
M0-88	2.609	66.269	20,000	2,400	4.6	3.8	22.23	26.99	11.11	59.53	28.58	6.35	41.28
LXS-882	2.609	66.269	29,000	2,800	4.6	3.9	22.23	28.58	11.11	59.53	28.58	6.35	42.86
M0H-578	2.609	66.269	19,000	2,200	4.6	2.7	22.23	26.99	9.53	52.78	25.40	5.56	36.12

Straight Side Bar Roller Chain

Straight Side Bar Roller Chain

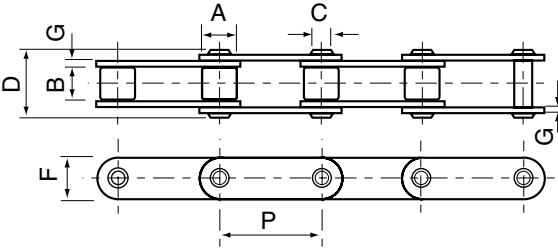

Material Spec.				
	Side Bar	Pin	Bushing	Roller
MS-88	C	CH	CC	CC
81-X	CH	AC	AC	CH
81-XH	CH	AC	AC	CH
81-XHS	CH	AC	AC	CH
SS-188	CH	AC	CC	CC

Chain number	Pitch		Average Ultimate Strength lbf	Max. Working Load lbf	Links Per Foot	Average Weight lb/ft	Dimensions							Side Plate Thickness (G)	
	inch	mm					A	B	C	D	F	K	Chain	Conn	
MS-88	2.609	66.269	26,000	2,500	4.6	3.8	22.23	26.99	11.11	59.53	28.58	41.28	6.35	6.35	
81-X	2.609	66.269	22,000	2,200	4.6	2.6	23.02	26.99	11.11	47.23	28.58	34.93	3.97	3.97	
81-XH	2.609	66.269	41,800	5,000	4.6	3.9	23.02	26.99	11.11	59.18	31.75	42.86	7.94	5.56	
81-XHS	2.609	66.269	41,800	5,000	4.6	4.2	23.02	26.99	11.11	63.50	32.94	42.86	7.94	7.94	
SS-188	2.609	66.269	26,000	2,500	4.6	3.8	22.23	26.99	11.11	59.53	28.58	41.28	6.35	6.35	

Material Designation:

C: Carbon Steel
 CC: Carbon Steel Case Hardened

AC: Alloy Steel Case Hardened
 CH: Carbon Steel Heat Treated

AH: Alloy Steel Heat Treated

All dimensions in millimetres unless otherwise stated. Every effort has been taken to ensure that the data listed in this catalogue is correct. Challenge accepts no liability for any inaccuracies or damage caused.

Timber Chain

Welded Steel Drag Chain

Chain Number	Pitch		Average Ultimate Strength lbf	Max. Working Load lbf	Links Per Foot	Average Weight lb/ft	Dimensions					
	mm	Inches					CE	X	A	E	D	F
WD104	152.4	6	51000	8500	2.0	8.7	174.75	136.65	19.05	9.65	104.65	38.1
WD110	152.4	6	51000	8500	2.0	12.0	301.75	263.65	19.05	9.65	228.60	38.1
WD120	152.4	6	80000	12300	2.0	19.4	304.80	257.05	22.35	12.70	215.90	50.8
WD122	203.2	8	80000	12300	1.5	16.0	304.80	257.05	22.35	12.70	215.90	50.8
WD480	203.2	8	80000	12300	1.5	18.1	371.35	323.75	22.35	12.70	279.40	50.8

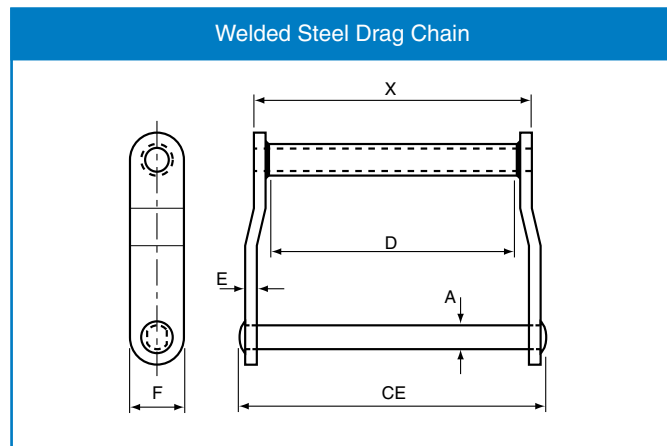

Drag Chain Attachments

Attachment number	Chain Ref	Dimensions			
		S	B	G	T
C1	WD104	104.65	9.53	57.15	9.53
W1	WD104	304.80	47.63	-	9.53
W1	WD120	431.80	44.45	-	12.70

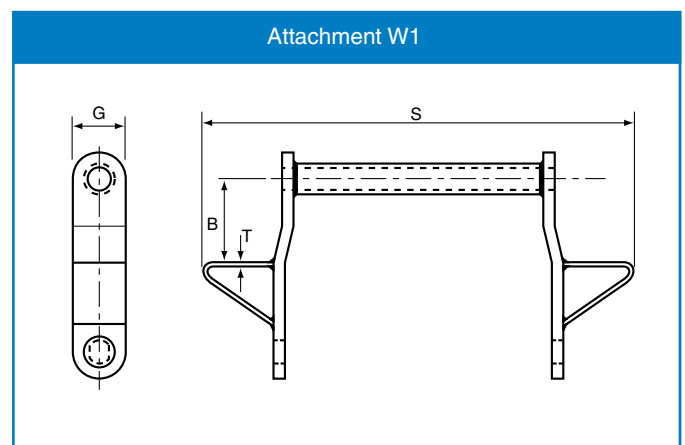
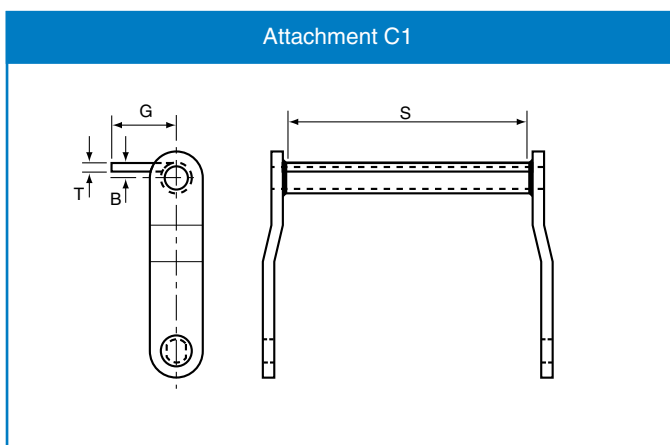

Agricultural Chain

Steel Agricultural Chain

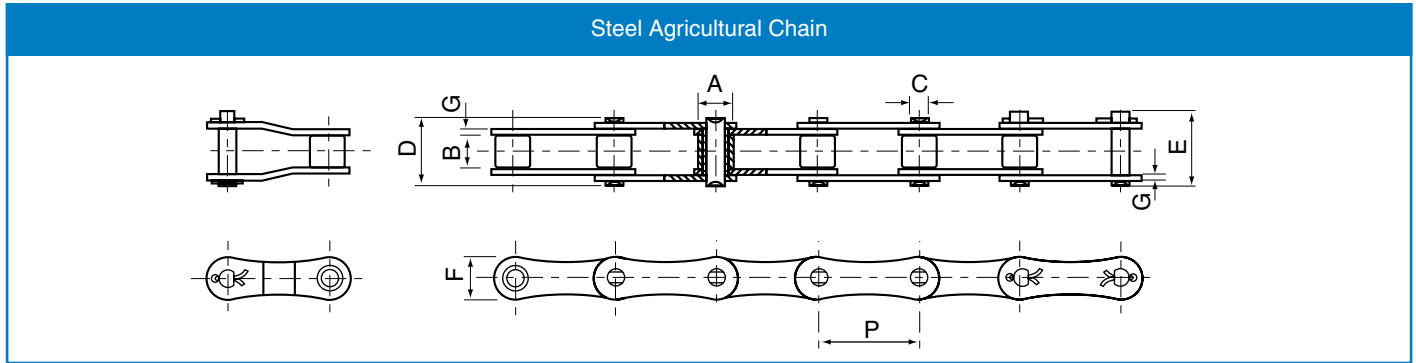

Chain number	Pitch	Roller diameter	Width between inner plates	Pin diameter	Pin length		Side plate height	Plate thickness	Minimum tensile strength	Average tensile strength	Weight
	P	A	B	C	D	E	F	G	kN	kN	kg/m
S32	29.21	11.43	15.88	4.45	26.70	28.80	13.20	1.80	8.00	21.60	0.86
S42	34.93	14.27	19.05	7.00	34.30	37.00	19.80	2.80	27.00	50.80	1.60
S45	41.40	15.24	22.23	5.72	37.70	40.40	17.30	2.80	18.00	36.10	1.66
S52	38.10	15.24	22.23	5.72	37.70	40.40	17.30	2.80	18.00	36.10	1.68
S55	41.40	17.78	22.23	5.72	37.70	40.40	17.30	2.80	18.00	36.10	1.80
S55X	41.40	15.88	20.00	8.28	38.00	40.70	20.00	3.00	50.00	55.00	2.20
S55R	41.40	17.78	22.23	8.90	41.00	44.00	22.40	3.50	45.00	73.10	2.49
S62	41.91	19.05	25.40	5.72	40.30	43.00	17.30	2.50	27.00	36.10	1.87
S77	58.34	18.26	22.23	8.90	43.20	46.40	26.20	4.00	45.00	73.10	2.65
S88	66.27	22.86	28.58	8.90	49.80	53.00	26.20	4.00	45.00	73.10	3.25

Steel Agricultural Chain

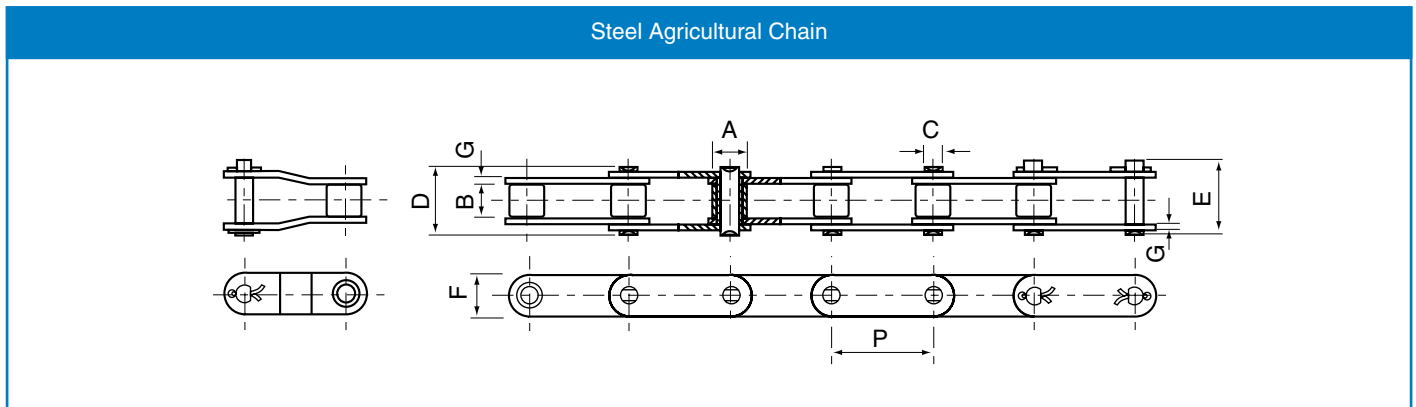

Chain number	Pitch	Roller diameter	Width between inner plates	Pin diameter	Pin length		Side plate height	Plate thickness	Minimum tensile strength	Average tensile strength	Weight
	P	A	B	C	D	E	F	G	kN	kN	kg/m
38.4	38.400	15.88	19.05	6.92	33.80	37.00	17.30	2.50	25.00	33.00	1.65
38.4-V	38.400	15.88	18.00	6.92	33.80	37.00	17.30	3.00	31.50	40.00	1.74
38.4-VB	38.400	15.88	19.05	8.27	36.20	39.40	20.50	3.00	45.00	50.00	2.12
CA550	41.400	16.87	19.81	7.19	35.00	38.00	19.30	2.80	39.10	51.20	1.94
CA555	41.400	16.87	12.70	7.19	29.70	33.10	19.30	3.10	39.10	56.00	1.83
CA557	41.400	17.78	20.24	8.00	37.40	40.60	23.10	3.10	55.61	74.30	2.20
CA620	42.010	17.91	24.51	7.19	41.80	45.20	20.20	3.25	39.10	55.10	2.35
CA650	50.800	25.00	27.80	9.53	40.40	44.70	25.00	4.00	80.00	95.50	3.49
CA2060H	38.100	11.91	12.70	5.94	29.74	31.72	17.45	3.25	31.28	40.50	1.50
CA2063H	38.100	11.89	12.70	5.94	29.40	34.20	19.30	3.25	31.28	40.50	1.65

All dimensions in millimetres unless otherwise stated. Every effort has been taken to ensure that the data listed in this catalogue is correct. Challenge accepts no liability for any inaccuracies or damage caused.

Agricultural Chain Attachments

S Series A1 & K1 Attachments

Chain number	P	G	J	K	M	O	W
S32	29.21	1.80	21.50	30.50	8.60	5.30	6.90
S42	34.93	2.80	27.00	37.45	14.00	8.30	11.50
S45	41.40	2.80	27.00	37.50	11.40	8.50	11.70
S52	38.10	2.80	29.40	39.00	11.40	8.30	9.90
S55	41.40	2.80	27.00	37.50	11.40	8.50	11.70
S62	41.91	2.50	33.40	47.70	11.40	6.50	13.00
S77	58.34	4.00	38.10	50.80	20.80	8.40	11.70
S88	66.27	4.00	48.50	59.70	20.80	8.40	10.00

A1 = Attachment one side only
K1 = Attachment both sides

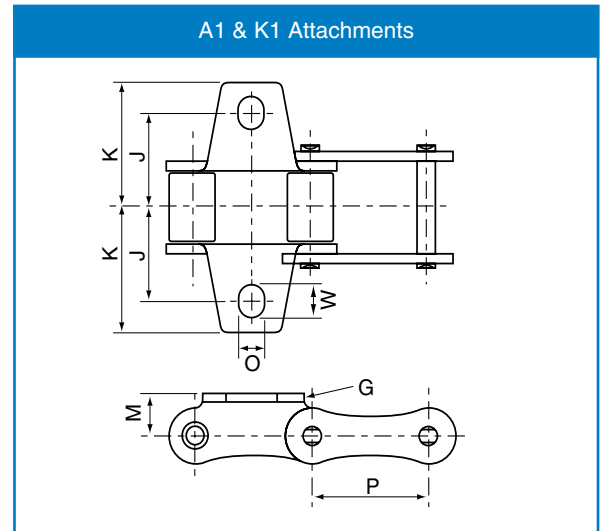

38.4 & CA Series A1 & K1 Attachments

Chain number	P	G	J	K	M	O	W
38.4	38.40	2.50	29.00	41.50	15.40	9.00	
38.4-V	38.40	3.00	28.75	41.00	15.40	9.00	
38.4-VB	38.40	3.00	29.00	43.50	14.00	10.50	
CA550	41.40	2.80	26.25	38.10	12.70	8.30	10.00
CA557	41.40	3.10	25.40	36.00	15.90	8.70	

A1 = Attachment one side only
K1 = Attachment both sides

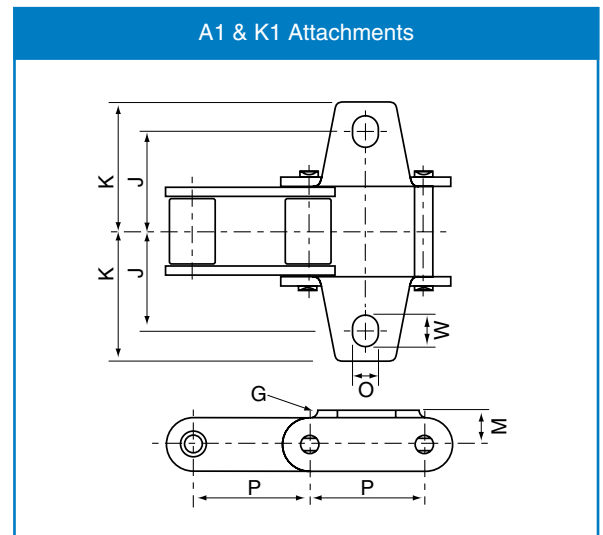

S, 38.4 & CA Series SD Attachments

Chain number	P	G	Q	J	K	H	X	O
S45	41.40	2.80	26.00	29.00	44.25	16.00	24.00	6.40
S55	41.40	2.80	26.00	29.00	44.25	16.00	24.00	6.40
38.4	38.40	2.50	37.00	26.00	35.50	24.00	38.40	8.40
38.4-VB	38.40	3.00	34.00	26.00	35.50	25.00	32.40	6.50
CA550	41.40	2.80	42.90	23.80	34.10	31.00	36.90	8.70

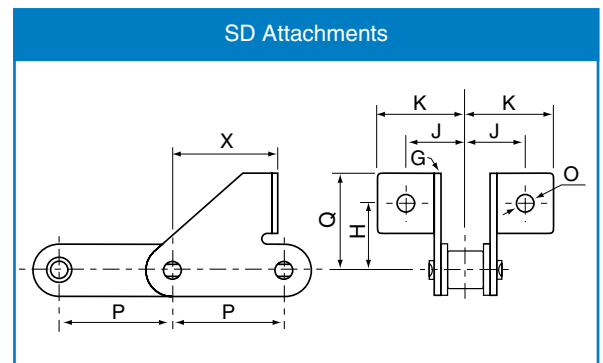

Agricultural Chain Attachments

“S” Type Roller Chain with Slats

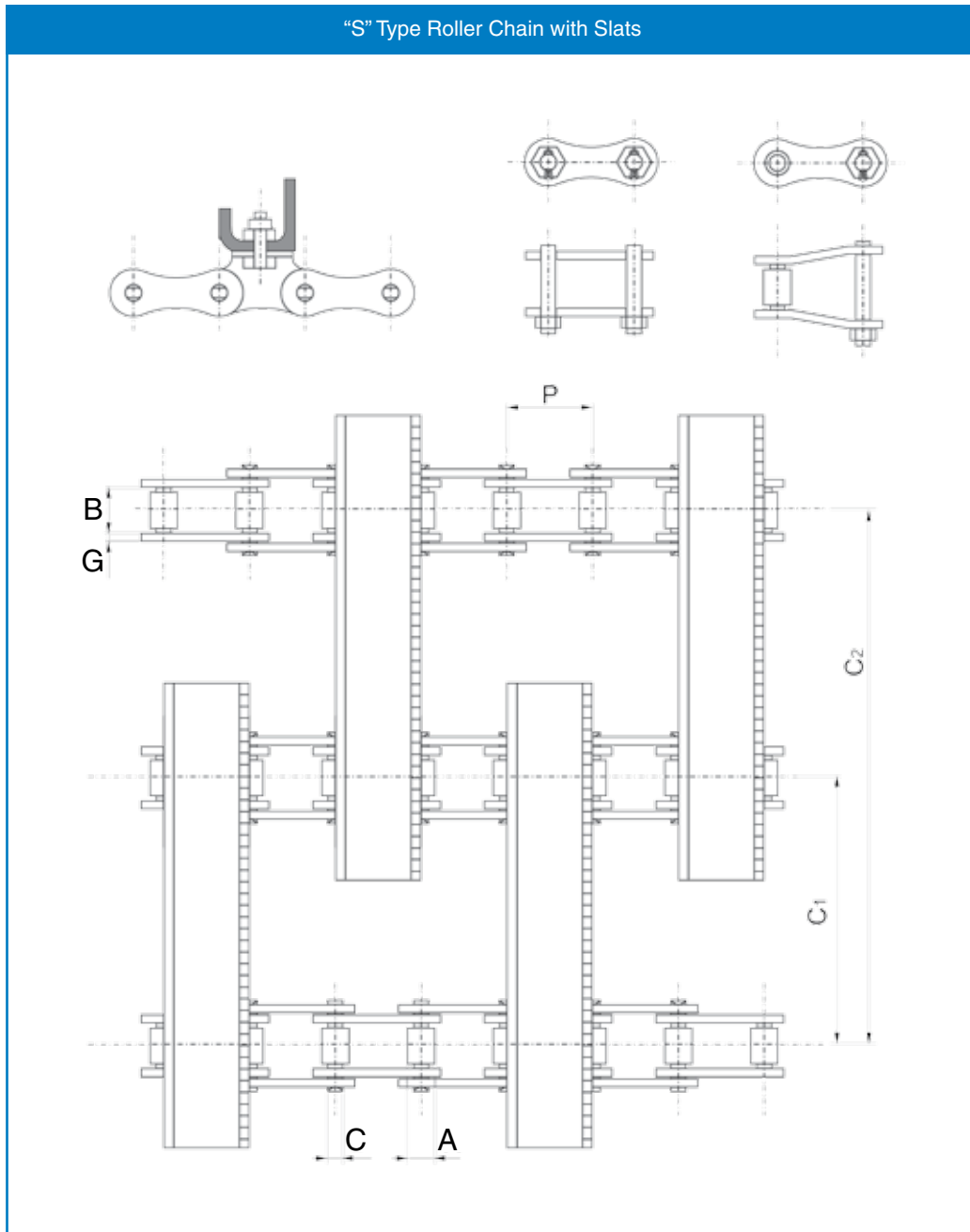

Chain number	Pitch	Roller diameter	Width between inner plates	Pin diameter	Side plate thickness			Weight
	P	A	B	C	G	C1	C2	kg/m
S55X/TM	41.40	15.88	20.00	8.28	3	500	1000	24

Note: Attachment slat dimensions can vary according to customer requirements - Please provide required dimensions on enquiry

Agricultural Chain Attachments

“S” Type Roller Chain with Tube

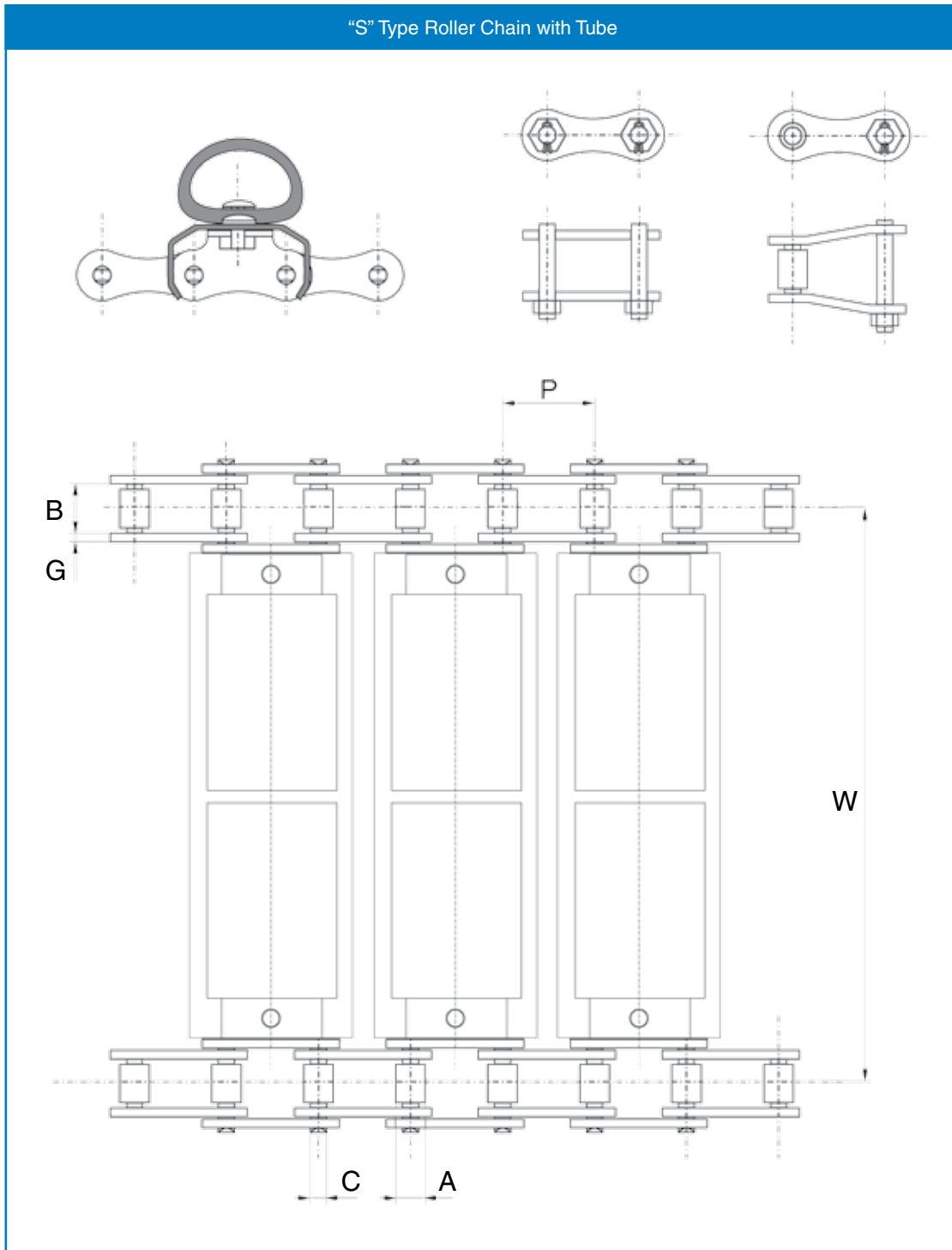

Chain Number	Pitch	Roller diameter	Width between inner plates	Pin diameter	Side plate thickness	
	P	A	B	C	G	W
S55X/TK-1	41.40	15.88	15.88	8.28	3.0	1372

Every effort has been taken to ensure that the data listed in this catalogue is correct. Challenge accepts no liability for any inaccuracies or damage caused. All dimensions in millimetres unless otherwise stated.

Agricultural Chain Attachments

“S” Type Roller Chains

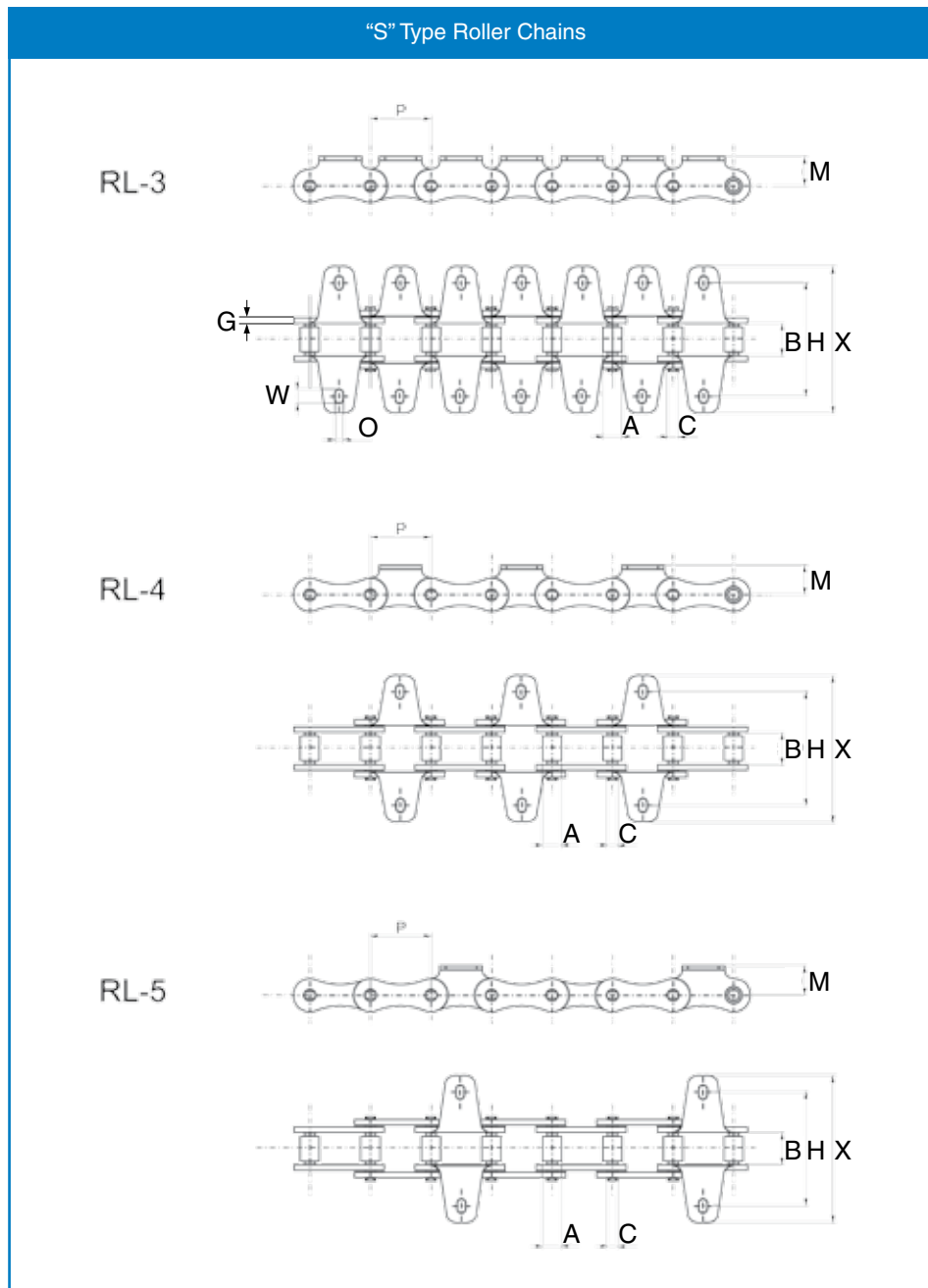

Chain number	Pitch	Roller diameter	Width between inner plates	Pin diameter	Side plate thickness	Attachment height					Average tensile strength
	P	A	B	C	G	H	X	M	O	W	kN
S55X/RL-3	41.40	15.88	20.00	8.28	3.00	52.00	79.40	17.00	8.30	10.00	55.00
S55X/RL-4	41.40	15.88	20.00	8.28	3.00	52.00	79.40	17.00	8.30	10.00	55.00
S55X/RL-5	41.40	15.88	20.00	8.28	3.00	52.00	79.40	17.00	8.30	10.00	55.00

All dimensions in millimetres unless otherwise stated. Every effort has been taken to ensure that the data listed in this catalogue is correct. Challenge accepts no liability for any inaccuracies or damage caused.

Agricultural Chain Attachments

“S” Type Roller Chains with Rubber Paddles

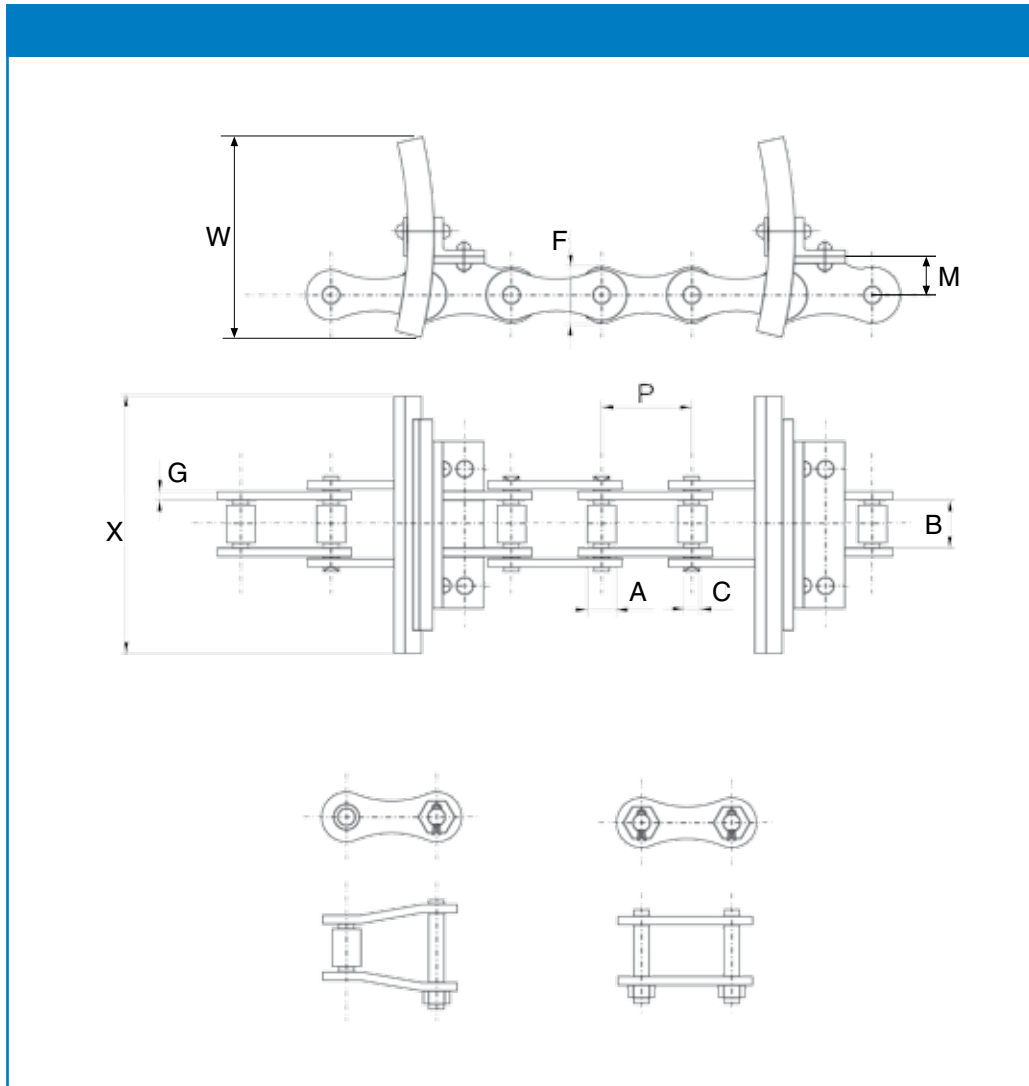

Chain number	Pitch	Roller diameter	Width between inner plates	Pin diameter	Side plate height	Side plate thickness	Attachment height	Paddle width	Paddle height	Tensile strength	Weight
	P	A	B	C	F	G	M	X	W	kN	kg/m
S55X/TM -1	41.40	15.88	20.00	8.28	20.00	3.00	17.00	110.00	52.00	50.00	3.80
S55X/TM -2	41.40	15.88	20.00	8.28	20.00	3.00	17.00	136.00	52.00	50.00	3.93
S55X/TM -3	41.40	15.88	20.00	8.28	20.00	3.00	17.00	166.00	52.00	50.00	5.30

Agricultural Chain Attachments

“S” Type Roller Chains

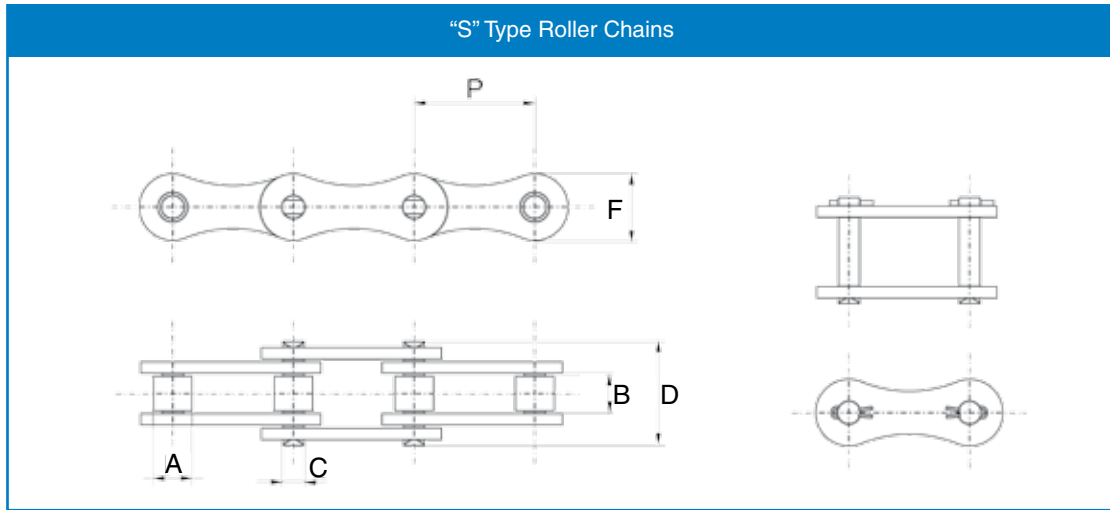

Chain	Pitch	Roller diameter	Width between inner plates	Pin diameter	Side plate height	Pin length	Average tensile strength
	P	A	B	C	F	D	kN
S55X/TM-1	41.40	15.88	20.00	8.28	20.00	38.00	55.00

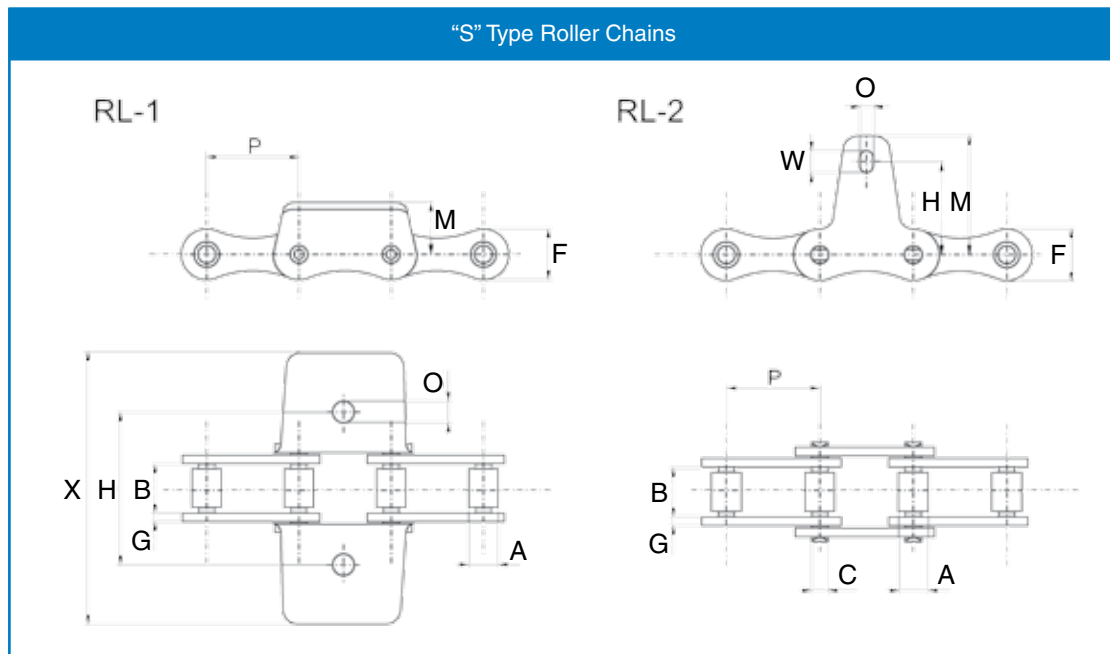

Chain	Pitch	Roller diameter	Width between inner plates	Pin diameter	Side plate height	Side plate thickness	Attachment height	Attachment height	Attachment height	Attachment height	Average tensile strength	
	P	A	B	C	F	G	H	X	M	O	W	kN
S55X RL-1	41.40	15.88	20.00	8.28	20.00	3.00	52.00	90.00	17.00	8.30	-	55.00
S55X RL-2	41.40	15.88	20.00	8.28	20.00	3.00	23.70	-	34.40	8.30	10.00	55.00

All dimensions in millimetres unless otherwise stated. Every effort has been taken to ensure that the data listed in this catalogue is correct. Challenge accepts no liability for any inaccuracies or damage caused.

Agricultural Chain Attachments

CA Series K39M Attachments

Chain number	P	G	I	J	K	M	O
CA550	41.40	2.80	30.0	50.80	72.00	12.70	9.50
CA557	41.40	3.10	38.1	53.94	76.20	14.60	9.90

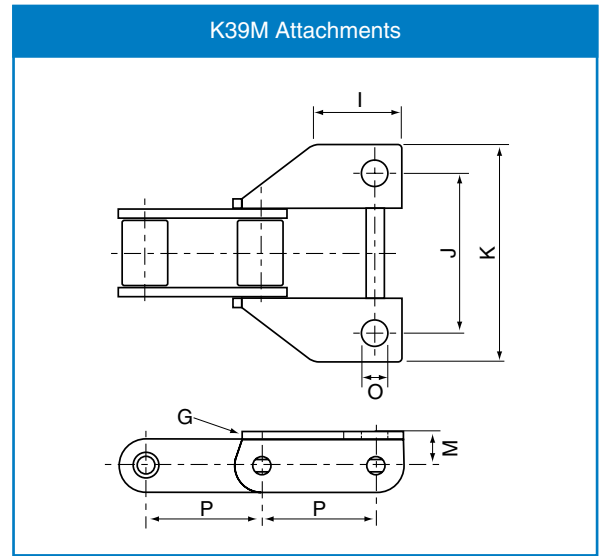

CA Series F14 Attachments

Chain number	P	G	J	K	M	O	W
CA550	41.40	2.80	31.75	79.40	101.60	8.33	15.90
CA557	41.40	3.10	31.75	79.40	101.60	8.33	15.90

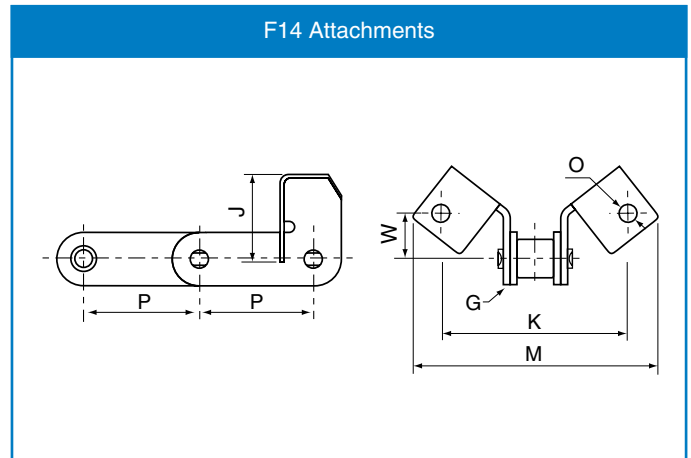

CA Series AA3 Attachments

Chain number	P	G	J	K	M	H	O	S ₁
CA557	41.40	3.10	31.90	43.29	30.20	31.06	8.20	9.73

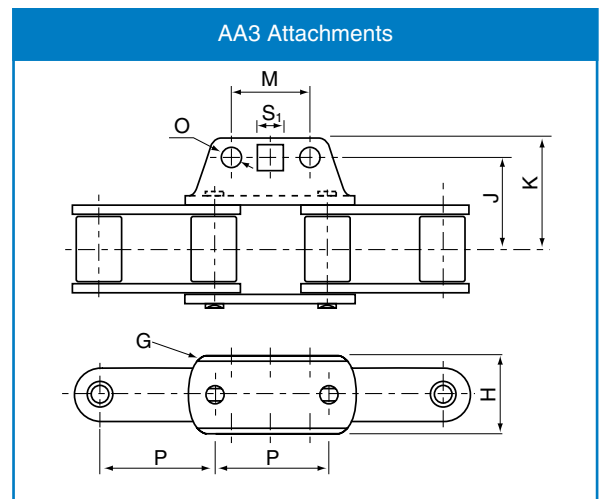

Agricultural Chain Attachments

CA Series C6E Attachments

Chain number	P	G	C	J	K	α°
CA550	41.40	2.80	55.60	23.60	13.50	20.00
CA555	41.40	3.10	63.50	23.60	13.50	15.00
C2060H	38.10	3.25	63.50	-	-	22.50

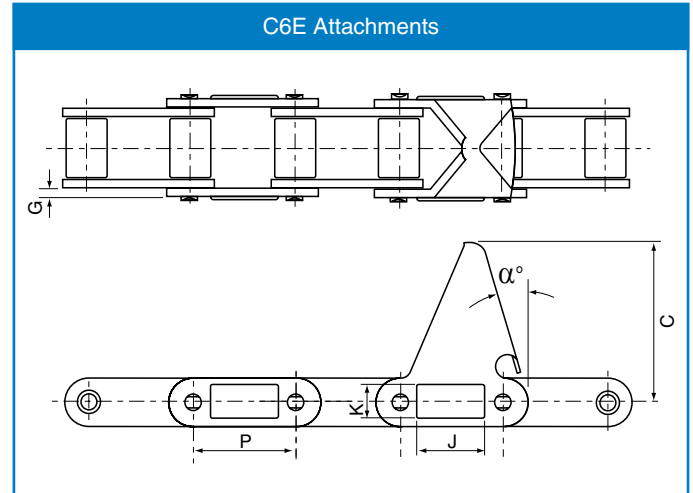

CA Series C5E Attachments

Chain number	P	G	C	α°
CA550	41.40	2.80	59.00	15.00
CA555	41.40	3.10	57.15	15.00

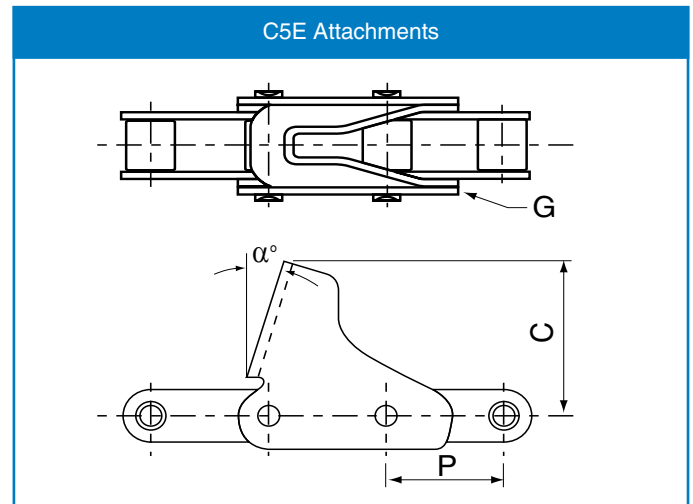

CA Series C11E Attachments

Chain number	P	G	C	J	K	α°
CA550	41.40	2.80	59.00	23.60	13.50	15.00

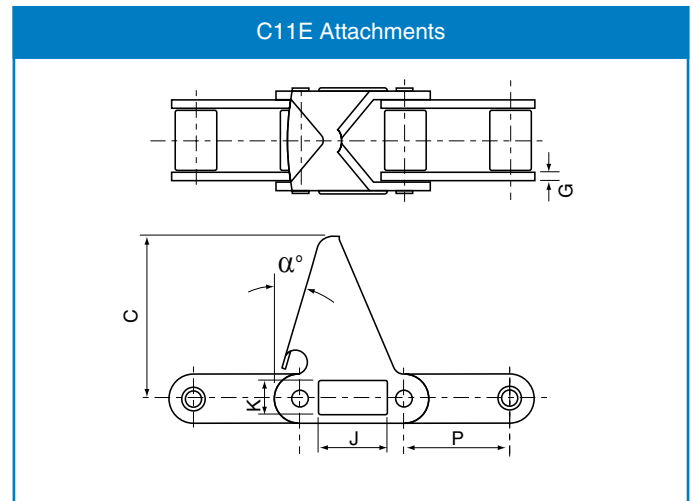

All dimensions in millimetres unless otherwise stated. Every effort has been taken to ensure that the data listed in this catalogue is correct. Challenge accepts no liability for any inaccuracies or damage caused.

Agricultural Chain Attachments

CA Series C12E Attachments

Chain number	P	G	C	α°
CA550	41.40	2.80	59.00	9.00

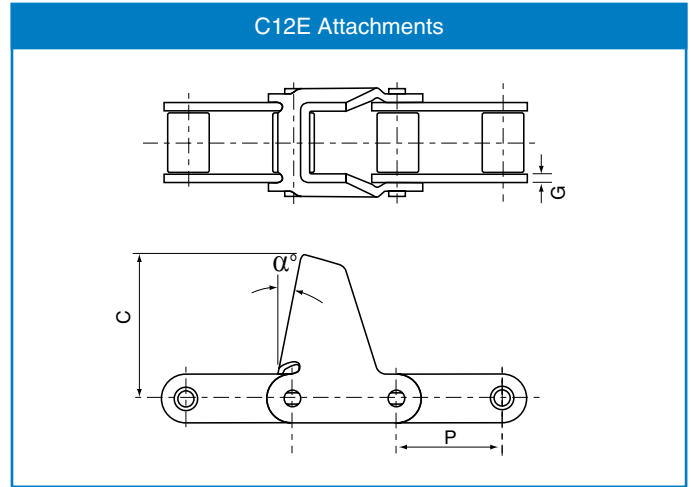

CA Series C13E Attachments

Chain number	P	G	C	J	K	α°
CA550	41.40	2.80	92.10	23.60	13.50	15.00

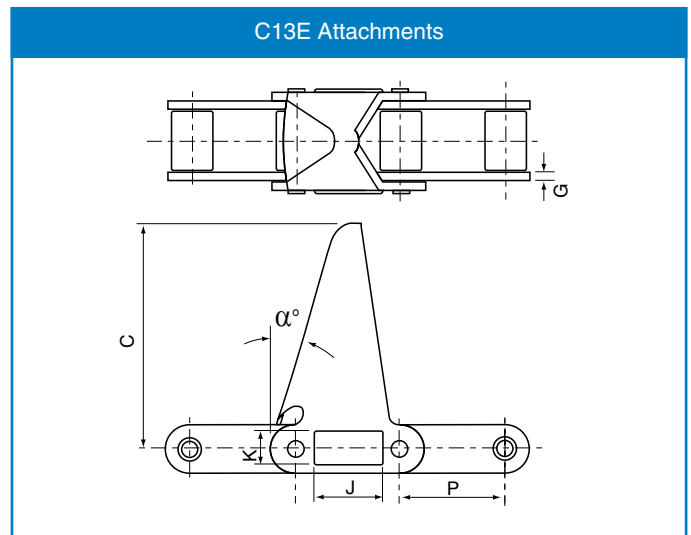

CA Series C17E Attachments

Chain number	P	G	C	J	K	α°
CA550	41.40	2.80	76.20	23.60	13.50	15.00

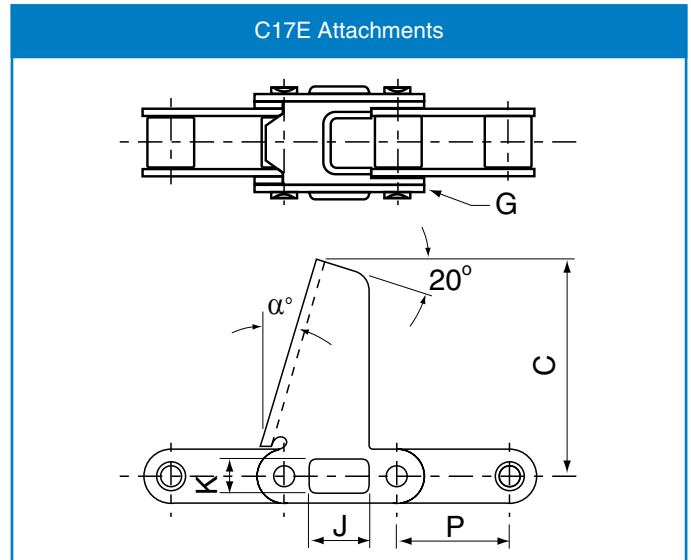

Every effort has been taken to ensure that the data listed in this catalogue is correct. Challenge accepts no liability for any inaccuracies or damage caused. All dimensions in millimetres unless otherwise stated.

Agricultural Chain Attachments

Chains with RM Attachments

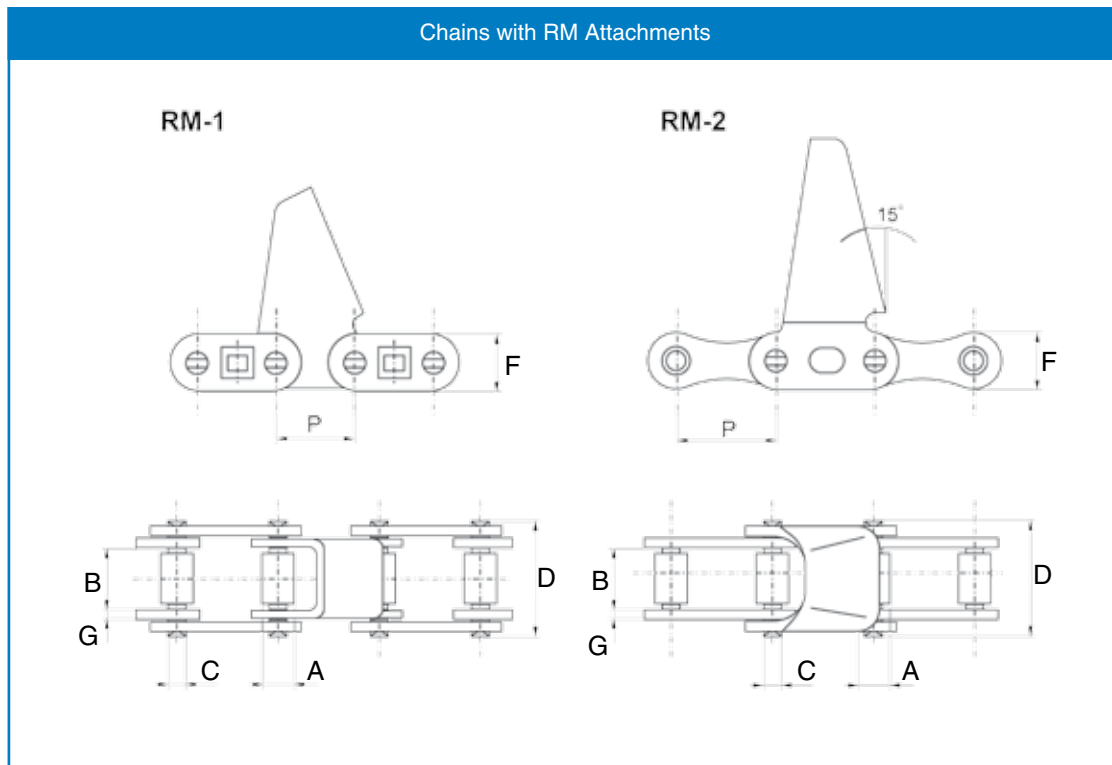

Model	Pitch	Roller diameter	Width between inner plates	Pin diameter	Pin length	Side plate height	Plate thickness	Minimum tensile strength
	P	A	B	C	D	F	G	kN
RM1	30.00	15.88	20.00	8.28	35.80	20.70	3.00	40.00
RM2	30.00	15.88	20.00	8.28	38.00	20.00	3.00	40.00

All dimensions in millimetres unless otherwise stated. Every effort has been taken to ensure that the data listed in this catalogue is correct. Challenge accepts no liability for any inaccuracies or damage caused.

Conveyor Chain

Z Series

BS Conveyor Chain (BS 4116 Part 4)

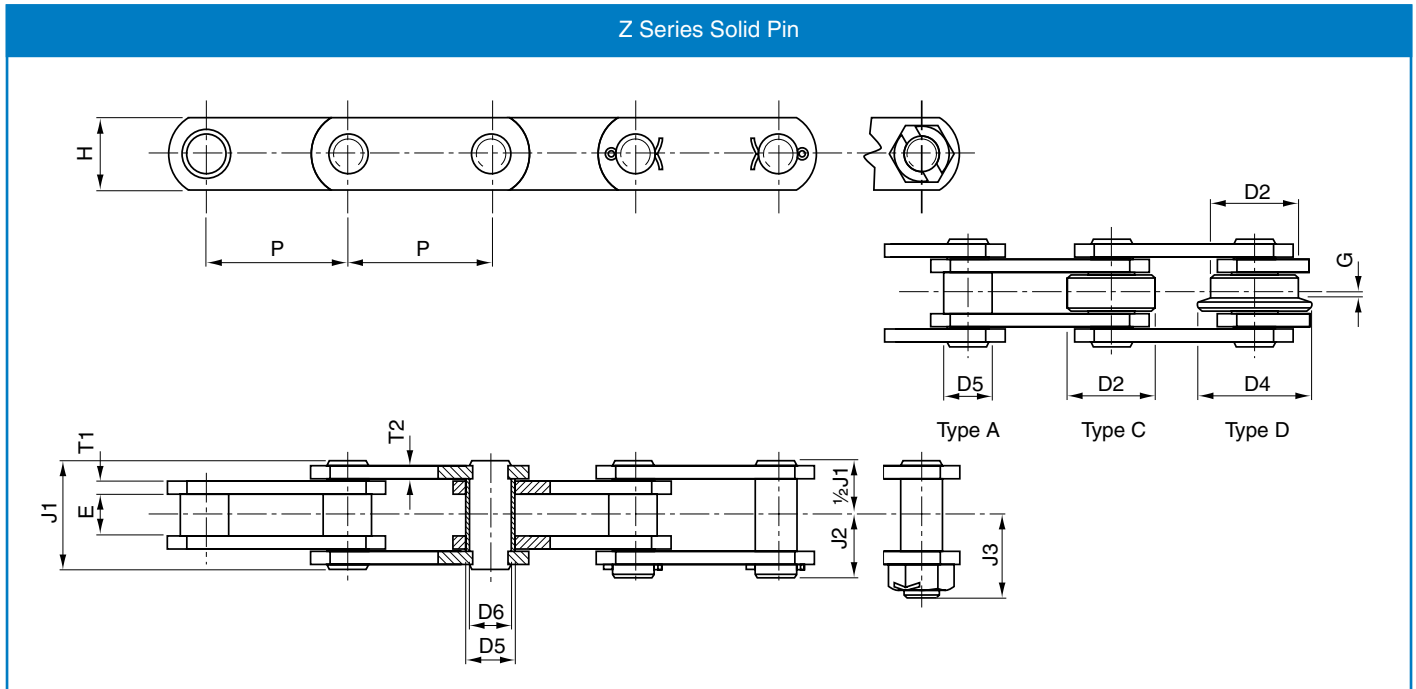

Solid Pin

Chain number	Minimum Breaking Load, lbf	Pitch Inches P	Pitch mm P	E	H	T1	T2	J1	J2	J3	D2	D4	D5	D6	G	Breaking Load kN	Weight (Type C) kg/m
Z40	7 500	2.0	50.8	15.2	25.4	3.8	4	39.5	22	28.5	31.75	40	19	14	2.5	40	4.0
Z40	"	2.5	63.5	"	"	"	"	"	"	"	"	"	"	"	"	"	3.5
Z40	"	3.0	76.2	"	"	"	"	"	"	"	"	"	"	"	"	"	3.2
Z40	"	3.5	88.9	"	"	"	"	"	"	"	"	"	"	"	"	"	3.0
Z40	"	4.0	101.6	"	"	"	"	"	"	"	"	"	"	"	"	"	2.8
Z40	"	5.0	127.0	"	"	"	"	"	"	"	"	"	"	"	"	"	2.6
Z40	"	6.0	152.4	"	"	"	"	"	"	"	"	"	"	"	"	"	2.4
Z100	15 000	3.0	76.2	19.6	38.2	5.1	4	46.1	28	37	47.63	60	25.4	19	3.5	100	7.7
Z100	"	3.5	88.9	"	"	"	"	"	"	"	"	"	"	"	"	"	7.0
Z100	"	4.0	101.6	"	"	"	"	"	"	"	"	"	"	"	"	"	6.5
Z100	"	5.0	127.0	"	"	"	"	"	"	"	"	"	"	"	"	"	5.8
Z100	"	6.0	152.4	"	"	"	"	"	"	"	"	"	"	"	"	"	5.3
Z100	"	7.0	177.8	"	"	"	"	"	"	"	"	"	"	"	"	"	5.0
Z100	"	8.0	203.2	"	"	"	"	"	"	"	"	"	"	"	"	"	4.7
Z160	30 000	4.0	101.6	25.5	50.8	7.1	5.1	59.13	34.5	51	66.7	82	34.9	26.9	3.5	156	14.3
Z160	"	5.0	127.0	"	"	"	"	"	"	"	"	"	"	"	"	"	12.5
Z160	"	6.0	152.4	"	"	"	"	"	"	"	"	"	"	"	"	"	11.3
Z160	"	7.0	177.8	"	"	"	"	"	"	"	"	"	"	"	"	"	10.5
Z160	"	8.0	203.2	"	"	"	"	"	"	"	"	"	"	"	"	"	9.8
Z160	"	9.0	228.6	"	"	"	"	"	"	"	"	"	"	"	"	"	9.3
Z160	"	10.0	254.0	"	"	"	"	"	"	"	"	"	"	"	"	"	9.0
Z300	45 000	6.0	152.4	38	65	10	8	82.5	47	70	88.9	107.9	41.3	31.75	8.5	300	24.3
Z300	"	7.0	177.8	"	"	"	"	"	"	"	"	"	"	"	"	"	22.0
Z300	"	8.0	203.2	"	"	"	"	"	"	"	"	"	"	"	"	"	21.0
Z300	"	10.0	254.0	"	"	"	"	"	"	"	"	"	"	"	"	"	18.0
Z300	"	12.0	304.8	"	"	"	"	"	"	"	"	"	"	"	"	"	16.5

Every effort has been taken to ensure that the data listed in this catalogue is correct. Challenge accepts no liability for any inaccuracies or damage caused. All dimensions in millimetres unless otherwise stated.

Conveyor Chain

ZC Series

BS Conveyor Chain (BS 4116 Part 4)

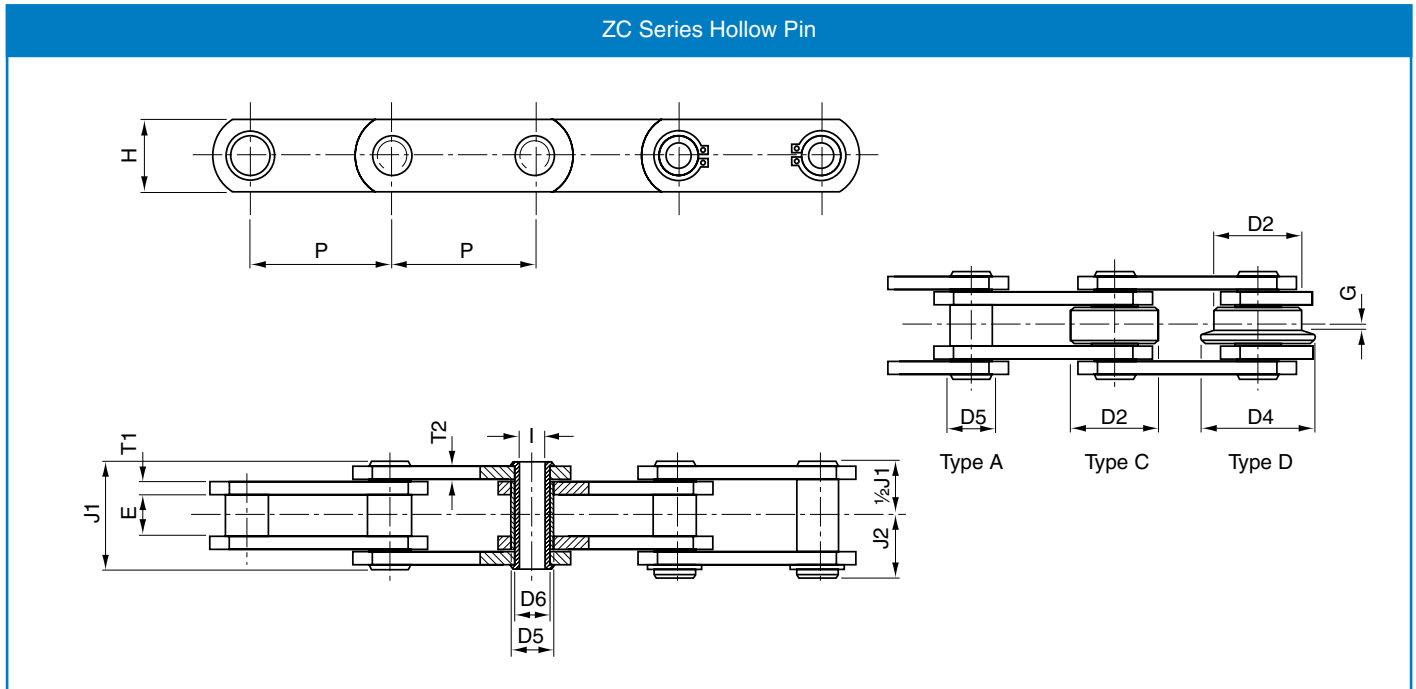

Hollow Pin

Chain number	Minimum Breaking Load, lbf	Pitch Inches P	Pitch mm P	E	I	H	T1	T2	J1	J2	D2	D4	D5	D6	G	Breaking Load kN	Weight (Type C) kg/m
ZC21	4 500	1.5	38.1	12.7	6.5	18	2.5	2.5	26	14.5	25.4	/	11	9	/	21	2.2
ZC21	"	2.0	50.8	"	"	"	"	"	"	"	"	"	"	"	"	"	1.7
ZC21	"	2.5	63.5	"	"	"	"	"	"	"	"	"	"	"	"	"	1.6
ZC21	"	3.0	76.2	"	"	"	"	"	"	"	"	"	"	"	"	"	1.4
ZC40	6 000	2.0	50.8	15.2	10.3	25.4	3.8	4	37.2	19.5	31.75	40	19	14	2.5	40	3.6
ZC40	"	2.5	63.5	"	"	"	"	"	"	"	"	"	"	"	"	"	3.2
ZC40	"	3.0	76.2	"	"	"	"	"	"	"	"	"	"	"	"	"	3.0
ZC40	"	3.5	88.9	"	"	"	"	"	"	"	"	"	"	"	"	"	2.8
ZC40	"	4.0	101.6	"	"	"	"	"	"	"	"	"	"	"	"	"	2.6
ZC40	"	5.0	127.0	"	"	"	"	"	"	"	"	"	"	"	"	"	2.4
ZC40	"	6.0	152.4	"	"	"	"	"	"	"	"	"	"	"	"	"	2.3
ZC60	12 000	3.0	76.2	19.16	13.2	38.2	5.1	4	44	23.5	47.63	60	25.4	19	3.5	60	7.0
ZC60	"	3.5	88.9	"	"	"	"	"	"	"	"	"	"	"	"	"	6.4
ZC60	"	4.0	101.6	"	"	"	"	"	"	"	"	"	"	"	"	"	6.0
ZC60	"	5.0	127.0	"	"	"	"	"	"	"	"	"	"	"	"	"	5.3
ZC60	"	6.0	152.4	"	"	"	"	"	"	"	"	"	"	"	"	"	4.9
ZC60	"	7.0	177.8	"	"	"	"	"	"	"	"	"	"	"	"	"	4.6
ZC60	"	8.0	203.2	"	"	"	"	"	"	"	"	"	"	"	"	"	4.4
ZC150	24 000	4.0	101.6	25.5	19.6	50.8	7.1	5.1	57	31.5	66.7	82	34.9	26.9	4	150	12.8
ZC150	"	5.0	127.0	"	"	"	"	"	"	"	"	"	"	"	"	"	11.3
ZC150	"	6.0	152.4	"	"	"	"	"	"	"	"	"	"	"	"	"	11.0
ZC150	"	7.0	177.8	"	"	"	"	"	"	"	"	"	"	"	"	"	9.5
ZC150	"	8.0	203.2	"	"	"	"	"	"	"	"	"	"	"	"	"	9.0
ZC150	"	9.0	228.6	"	"	"	"	"	"	"	"	"	"	"	"	"	8.6
ZC150	"	10.0	254.0	"	"	"	"	"	"	"	"	"	"	"	"	"	8.2
ZC300	36 000	6.0	152.4	38	23	65	10	8	82	43.5	88.9	107.9	41.3	31.75	8.5	300	22.3
ZC300	"	7.0	177.8	"	"	"	"	"	"	"	"	"	"	"	"	"	20.2
ZC300	"	8.0	203.2	"	"	"	"	"	"	"	"	"	"	"	"	"	18.8
ZC300	"	10.0	254.0	"	"	"	"	"	"	"	"	"	"	"	"	"	16.4
ZC300	"	12.0	304.8	"	"	"	"	"	"	"	"	"	"	"	"	"	15.2

All dimensions in millimetres unless otherwise stated. Every effort has been taken to ensure that the data listed in this catalogue is correct. Challenge accepts no liability for any inaccuracies or damage caused.

Conveyor Chain Attachments

Z/ZC Series Attachments

BS Conveyor Chain (BS 4116 Part 4)

Z/ZC Series Attachments

Note: Attachments are also available in A1, A2 and A3 (1, 2 and 3 hole, one side only) configuration

Conveyor Attachments

Chain Number	Minimum Breaking Load lbf	Pitch Inches P	Pitch mm P	Attachment Type	K	M	L	d	d1	O	Q	Average Weight (Each) kg
ZC40 / Z40	6 000/7 500	2.0	50.8	K1	19	76.2	45.0	10.6	/	129	/	0.10
ZC40 / Z40	"	2.5	63.5	K1, K2	"	"	43.0	"	9.2	112	22.2	0.10
ZC40 / Z40	"	3.0	76.2	K3	"	"	"	"	"	136	"	0.10
ZC40 / Z40	"	3.5	88.9	K1, K2, K3	"	"	50.0	"	"	112	31.8	0.10
ZC40 / Z40	"	4.0	101.6	K3	"	"	64.0	"	"	110	"	0.10
ZC40 / Z40	"	5.0	127.0	K3	"	"	85.0	"	"	112	57.2	0.20
ZC40 / Z40	"	6.0	152.4	K3	"	"	88.0	"	"	"	"	0.20
ZC100 / Z100	12 000 / 15 000	3.0	76.2	K1	31.8	88.9	35.0	13.87	/	130	/	0.12
ZC100 / Z100	"	3.5	88.9	K1	"	"	"	"	/	"	/	0.12
ZC100 / Z100	"	4.0	101.6	K3	"	"	64.0	"	11	"	31.8	0.10
ZC100 / Z100	"	5.0	127.0	K1, K2	"	"	56.0	"	"	"	57.2	0.30
ZC100 / Z100	"	6.0	152.4	K3	"	"	114.5	"	"	"	"	0.32
ZC100 / Z100	"	7.0	177.8	K1, K2	"	"	127.0	"	"	"	89.0	0.40
ZC100 / Z100	"	8.0	203.2	K1, K2	"	"	"	"	"	"	"	0.40
ZC160 / Z160	24 000 / 30 000	4.0	101.6	K1	38.1	108.0	35.0	15.5	/	154	/	0.19
ZC160 / Z160	"	5.0	127.0	K1, K2	"	"	56.0	"	12.7	"	31.7	0.30
ZC160 / Z160	"	6.0	152.4	K1, K2	"	"	84.0	"	"	"	57.2	0.38
ZC160 / Z160	"	7.0	177.8	K1, K2	"	"	108.0	"	"	"	"	0.38
ZC160 / Z160	"	8.0	203.2	K1, K2	"	"	127.0	"	"	"	88.9	0.60
ZC160 / Z160	"	9.0	228.6	K1, K2	"	"	168.0	"	"	"	"	0.69
ZC160 / Z160	"	10.0	254.0	K1, K2	"	"	168.0	"	"	"	133.35	0.75
ZC300 / Z300	36 000 / 45 000	6.0	152.4	K1	51	146.0	70.0	17.0	/	200	38.1	0.50
ZC300 / Z300	"	7.0	177.8	K1	"	"	"	"	/	"	"	0.50
ZC300 / Z300	"	8.0	203.2	K1, K2	"	"	100.0	"	14.0	"	76.2	0.70
ZC300 / Z300	"	10.0	254.0	K1, K2	"	"	152.4	"	"	"	90.0	0.90
ZC300 / Z300	"	12.0	304.8	K1, K2	"	"	225.0	"	"	"	190.0	1.60
Z300 / 60	60 000	6.0	152.4	K1	51	146.0	70.0	17.0	/	200	38.1	0.50
Z300 / 60	"	7.0	177.8	K1	"	"	"	"	/	"	"	0.50
Z300 / 60	"	8.0	203.2	K1, K2	"	"	100.0	"	14.0	"	76.2	0.70
Z300 / 60	"	10.0	254.0	K1, K2	"	"	152.4	"	"	"	90.0	0.90
Z300 / 60	"	12.0	304.8	K1, K2	"	"	225.0	"	"	"	190.0	1.60

Every effort has been taken to ensure that the data listed in this catalogue is correct. Challenge accepts no liability for any inaccuracies or damage caused. All dimensions in millimetres unless otherwise stated.

Conveyor Chain

ZE Series

BS Conveyor Chain (BS 4116 Part 4)

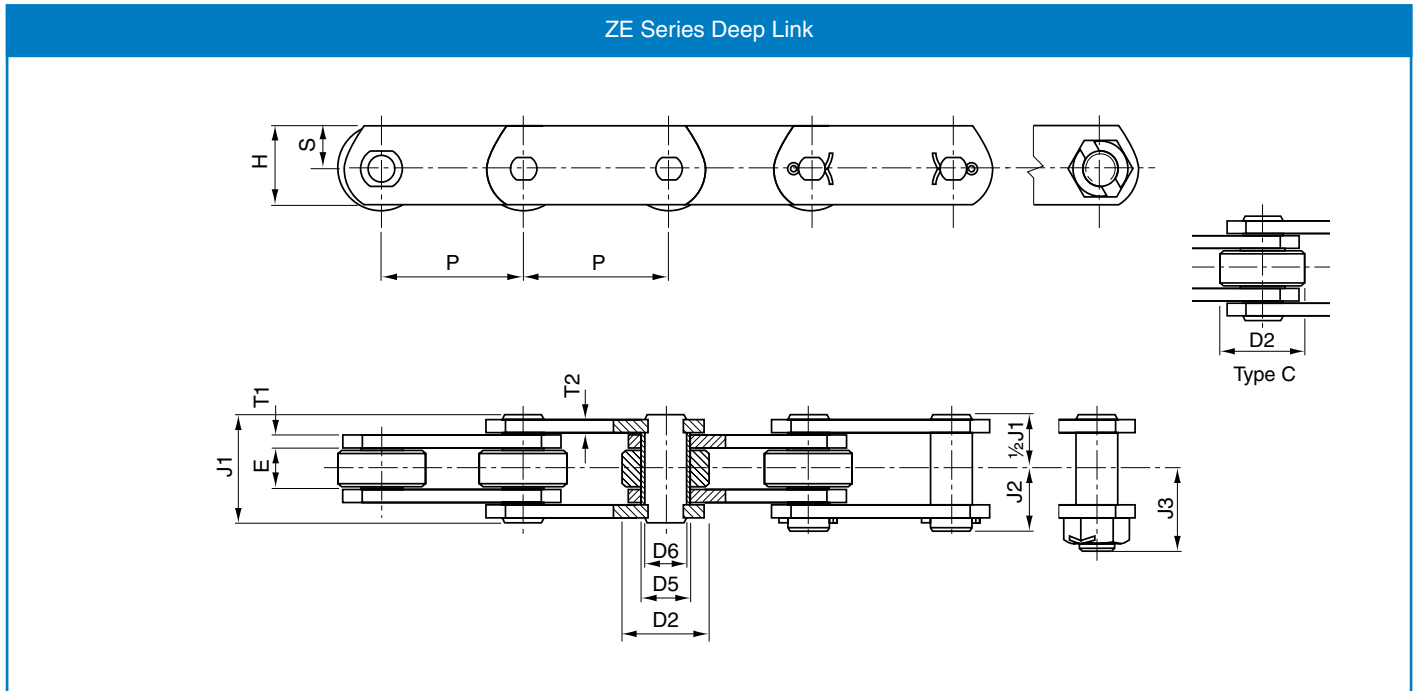

Deep Link

Chain Number	Minimum Breaking Load, lbf	Pitch Inches P	Pitch mm P	E	H	S	T1	T2	J1	J2	J3	D2	D5	D6	Breaking Load kN	Weight (Type C) kg/m
ZE40	7 500	2.0	50.8	15.2	38.1	27	3.8	4	3.9	22	28.5	31.75	19.05	14	40	5.0
ZE40	"	2.5	63.5	"	"	"	"	"	"	"	"	"	"	"	"	4.6
ZE40	"	3.0	76.2	"	"	"	"	"	"	"	"	"	"	"	"	4.2
ZE40	"	3.5	88.9	"	"	"	"	"	"	"	"	"	"	"	"	4.0
ZE40	"	4.0	101.6	"	"	"	"	"	"	"	"	"	"	"	"	3.8
ZE40	"	5.0	127.0	"	"	"	"	"	"	"	"	"	"	"	"	3.5
ZE40	"	6.0	152.4	"	"	"	"	"	"	"	"	"	"	"	"	3.3
ZE100	15 000	3.0	76.2	19	50.8	30	5.2	5.2	46.1	28	37	47.6	25.4	19	100	8.9
ZE100	"	3.5	88.9	"	"	"	"	"	"	"	"	"	"	"	"	8.4
ZE100	"	4.0	101.6	"	"	"	"	"	"	"	"	"	"	"	"	7.6
ZE100	"	5.0	127.0	"	"	"	"	"	"	"	"	"	"	"	"	6.8
ZE100	"	6.0	152.4	"	"	"	"	"	"	"	"	"	"	"	"	6.3
ZE100	"	7.0	177.8	"	"	"	"	"	"	"	"	"	"	"	"	5.9
ZE100	"	8.0	203.2	"	"	"	"	"	"	"	"	"	"	"	"	5.7
ZE160	30 000	4.0	101.6	25.5	70	45	7.1	5.2	59.1	34.5	51	66.7	34.9	26.9	160	17.5
ZE160	"	5.0	127.0	"	"	"	"	"	"	"	"	"	"	"	"	15.4
ZE160	"	6.0	152.4	"	"	"	"	"	"	"	"	"	"	"	"	13.8
ZE160	"	7.0	177.8	"	"	"	"	"	"	"	"	"	"	"	"	12.8
ZE160	"	8.0	203.2	"	"	"	"	"	"	"	"	"	"	"	"	12.0
ZE160	"	9.0	228.6	"	"	"	"	"	"	"	"	"	"	"	"	11.3
ZE160	"	10.0	254.0	"	"	"	"	"	"	"	"	"	"	"	"	10.5
ZE300	45 000	6.0	152.4	38	90	60	10	8	82.5	47	70	88.9	41.3	31.75	300	32.0
ZE300	"	7.0	177.8	"	"	"	"	"	"	"	"	"	"	"	"	29.5
ZE300	"	8.0	203.2	"	"	"	"	"	"	"	"	"	"	"	"	27.0
ZE300	"	10.0	254.0	"	"	"	"	"	"	"	"	"	"	"	"	24.5
ZE300	"	12.0	304.8	"	"	"	"	"	"	"	"	"	"	"	"	23.0
ZE300/60	60 000	6.0	152.4	38	90	60	10	8	84	52	71	88.9	38	32	300	32.0
ZE300/60	"	7.0	177.8	"	"	"	"	"	"	"	"	"	"	"	"	29.5
ZE300/60	"	8.0	203.2	"	"	"	"	"	"	"	"	"	"	"	"	27.0
ZE300/60	"	10.0	254.0	"	"	"	"	"	"	"	"	"	"	"	"	24.5
ZE300/60	"	12.0	304.8	"	"	"	"	"	"	"	"	"	"	"	"	23.0

All dimensions in millimetres unless otherwise stated. Every effort has been taken to ensure that the data listed in this catalogue is correct. Challenge accepts no liability for any inaccuracies or damage caused.

Conveyor Chain

M Series

Metric Conveyor Chain (DIN 8167)

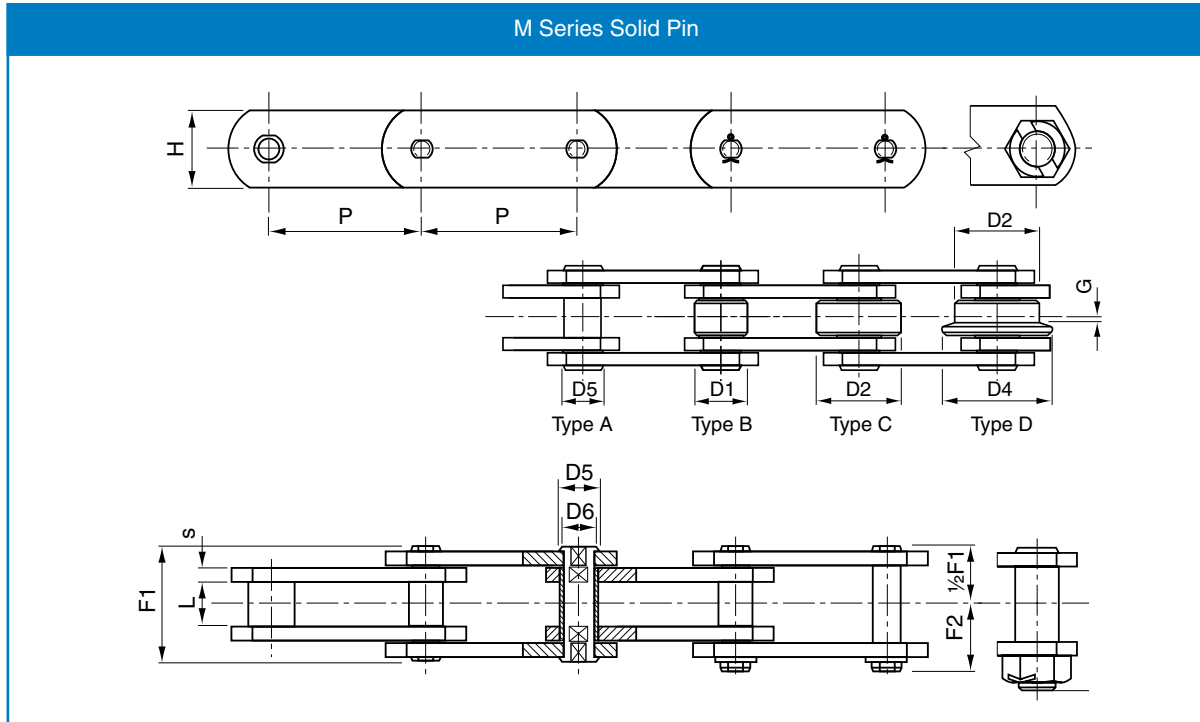

Solid Pin

Chain number	Pitch P	L	G	H	S	F1	F2	D1	D2	D4	D5	D6	Breaking Load kN	Weight (Type C) kg/m
M 20	40	16	3.5	18	2.5	33.0	19.0	12.5	25	32	9	6	20	2.4
"	50	"	"	"	"	"	"	"	"	"	"	"	"	2.0
"	63	"	"	"	"	"	"	"	"	"	"	"	"	1.8
"	80	"	"	"	"	"	"	"	"	"	"	"	"	1.6
M28	50	18	4.0	20	3	36.0	20.5	15.0	30	36	10	7	28	3.3
"	63	"	"	"	"	"	"	"	"	"	"	"	"	2.8
"	80	"	"	"	"	"	"	"	"	"	"	"	"	2.5
"	100	"	"	"	"	"	"	"	"	"	"	"	"	2.1
M 40	63	20	4.5	25	4	40.5	24.0	18.0	36	45	11	8	40	4.4
"	80	"	"	"	"	"	"	"	"	"	"	"	"	3.7
"	100	"	"	"	"	"	"	"	"	"	"	"	"	3.2
"	125	"	"	"	"	"	"	"	"	"	"	"	"	2.9
M 56	63	24	7.0	30	4	45.0	26.0	21.0	42	50	15	10	56	6.8
"	80	"	"	"	"	"	"	"	"	"	"	"	"	5.7
"	100	"	"	"	"	"	"	"	"	"	"	"	"	5.0
"	125	"	"	"	"	"	"	"	"	"	"	"	"	4.4
"	160	"	"	"	"	"	"	"	"	"	"	"	"	3.9
M 80	80	28	7.0	35	5	54.5	30.5	25.0	50	60	18	12	80	9.2
"	100	"	"	"	"	"	"	"	"	"	"	"	"	7.9
"	125	"	"	"	"	"	"	"	"	"	"	"	"	6.9
"	160	"	"	"	"	"	"	"	"	"	"	"	"	6.0
"	200	"	"	"	"	"	"	"	"	"	"	"	"	5.3

Conveyor Chain

M Series

Metric Conveyor Chain (DIN 8167)

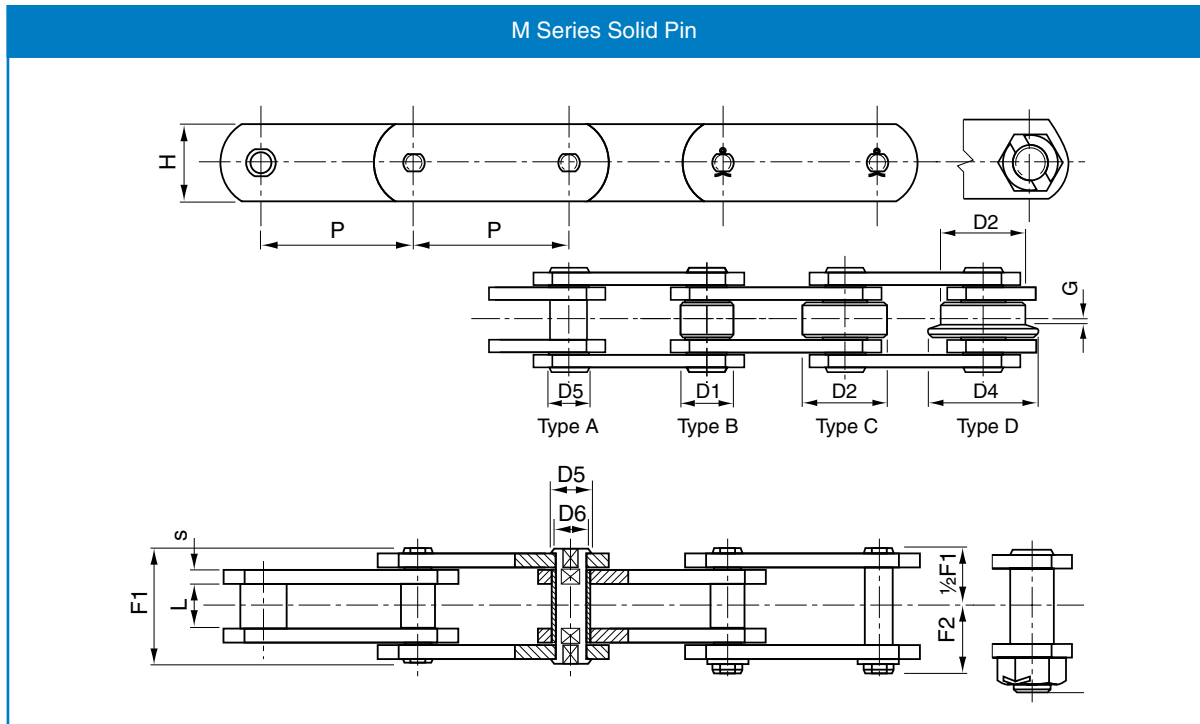

Solid Pin

Chain number	Pitch P	L	G	H	S	F1	F2	D1	D2	D4	D5	D6	Breaking Load kN	Weight (Type C) kg/m
M 112	80	32	7.5	40	6	63	36.0	30	60	75	21	15	112	14.0
"	100	"	"	"	"	"	"	"	"	"	"	"	"	12.0
"	125	"	"	"	"	"	"	"	"	"	"	"	"	10.4
"	160	"	"	"	"	"	"	"	"	"	"	"	"	9.0
"	200	"	"	"	"	"	"	"	"	"	"	"	"	7.9
M 160	100	37	8.5	50	7	72	41.5	36	70	90	25	18	160	18.9
"	125	"	"	"	"	"	"	"	"	"	"	"	"	16.3
"	160	"	"	"	"	"	"	"	"	"	"	"	"	14.0
"	200	"	"	"	"	"	"	"	"	"	"	"	"	12.2
"	250	"	"	"	"	"	"	"	"	"	"	"	"	11.0
M 224	125	43	10.0	60	8	84	47.0	42	85	105	30	21	224	25.8
"	160	"	"	"	"	"	"	"	"	"	"	"	"	22.0
"	200	"	"	"	"	"	"	"	"	"	"	"	"	19.0
"	250	"	"	"	"	"	"	"	"	"	"	"	"	16.7
"	315	"	"	"	"	"	"	"	"	"	"	"	"	14.9
M 315	160	48	10.5	70	10	97	55.0	50	100	124	36	25	315	33.3
"	200	"	"	"	"	"	"	"	"	"	"	"	"	28.7
"	250	"	"	"	"	"	"	"	"	"	"	"	"	25.2
"	315	"	"	"	"	"	"	"	"	"	"	"	"	22.3
"	400	"	"	"	"	"	"	"	"	"	"	"	"	20.0

All dimensions in millimetres unless otherwise stated. Every effort has been taken to ensure that the data listed in this catalogue is correct. Challenge accepts no liability for any inaccuracies or damage caused.

Conveyor Chain

M Series

Metric Conveyor Chain (DIN 8167)

M Series Solid Pin

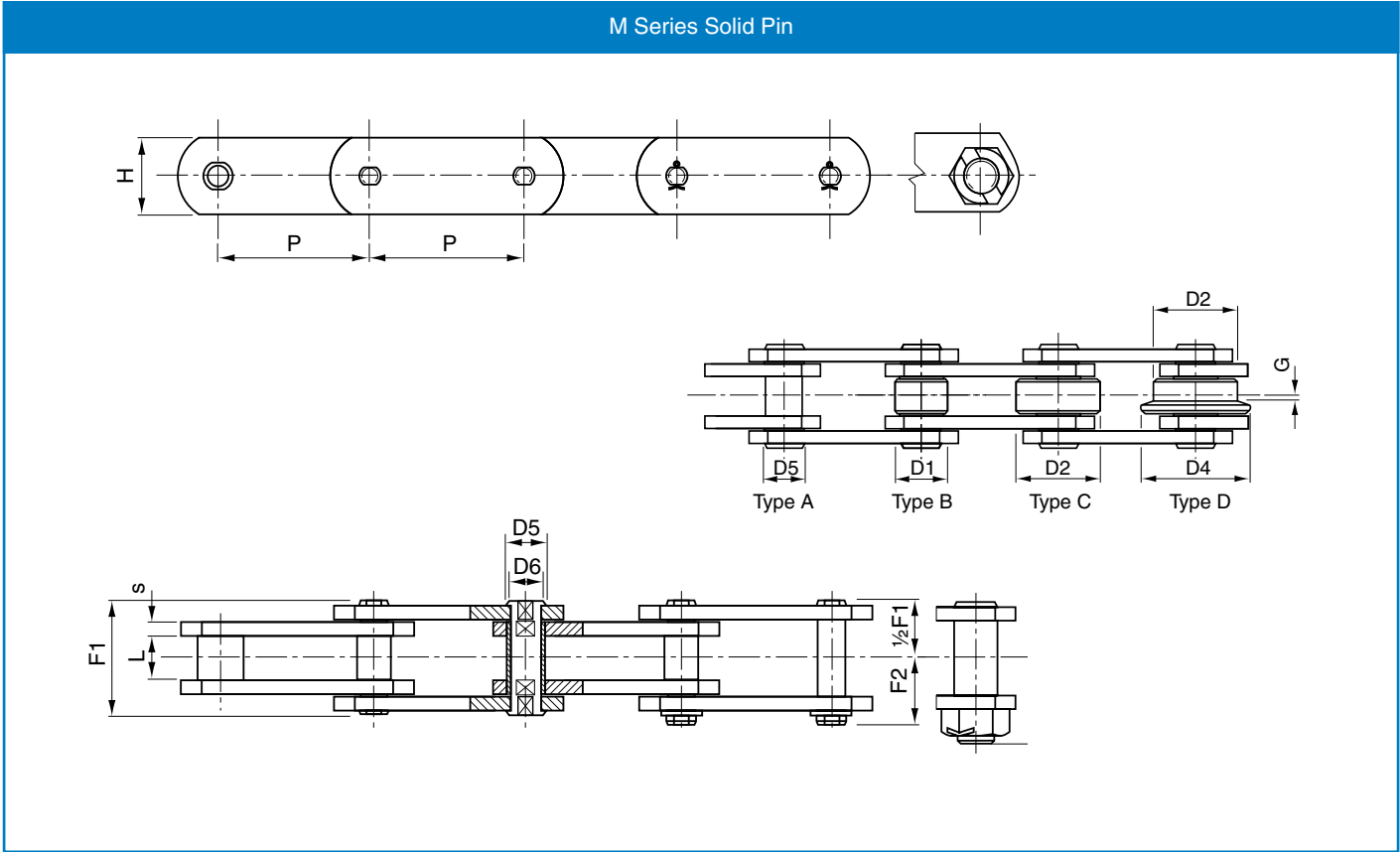

Solid Pin

Chain number	Pitch P	L	G	H	S	F1	F2	D1	D2	D4	D5	D6	Breaking Load kN	Weight (Type C) kg/m
M 450	200	56	11.5	80	12	114	67.0	60	120	149	42	30	450	40.5
"	250	"	"	"	"	"	"	"	"	"	"	"	"	39.5
"	315	"	"	"	"	"	"	"	"	"	"	"	"	34.5
"	400	"	"	"	"	"	"	"	"	"	"	"	"	30.5
M 630	250	67	15.0	100	14	137	87.5	70	140	170	50	36	630	64.0
"	315	"	"	"	"	"	"	"	"	"	"	"	"	55.5
"	400	"	"	"	"	"	"	"	"	"	"	"	"	49.0
"	500	"	"	"	"	"	"	"	"	"	"	"	"	43.6
M 900	250	78	17.0	120	16	153	95.0	85	170	210	60	44	900	98.3
"	315	"	"	"	"	"	"	"	"	"	"	"	"	84.2
"	400	"	"	"	"	"	"	"	"	"	"	"	"	72.5
"	500	"	"	"	"	"	"	"	"	"	"	"	"	63.8
"	600	"	"	"	"	"	"	"	"	"	"	"	"	56.6

Conveyor Chain Attachments

M Series Attachments

Metric Conveyor Chain (DIN 8167)

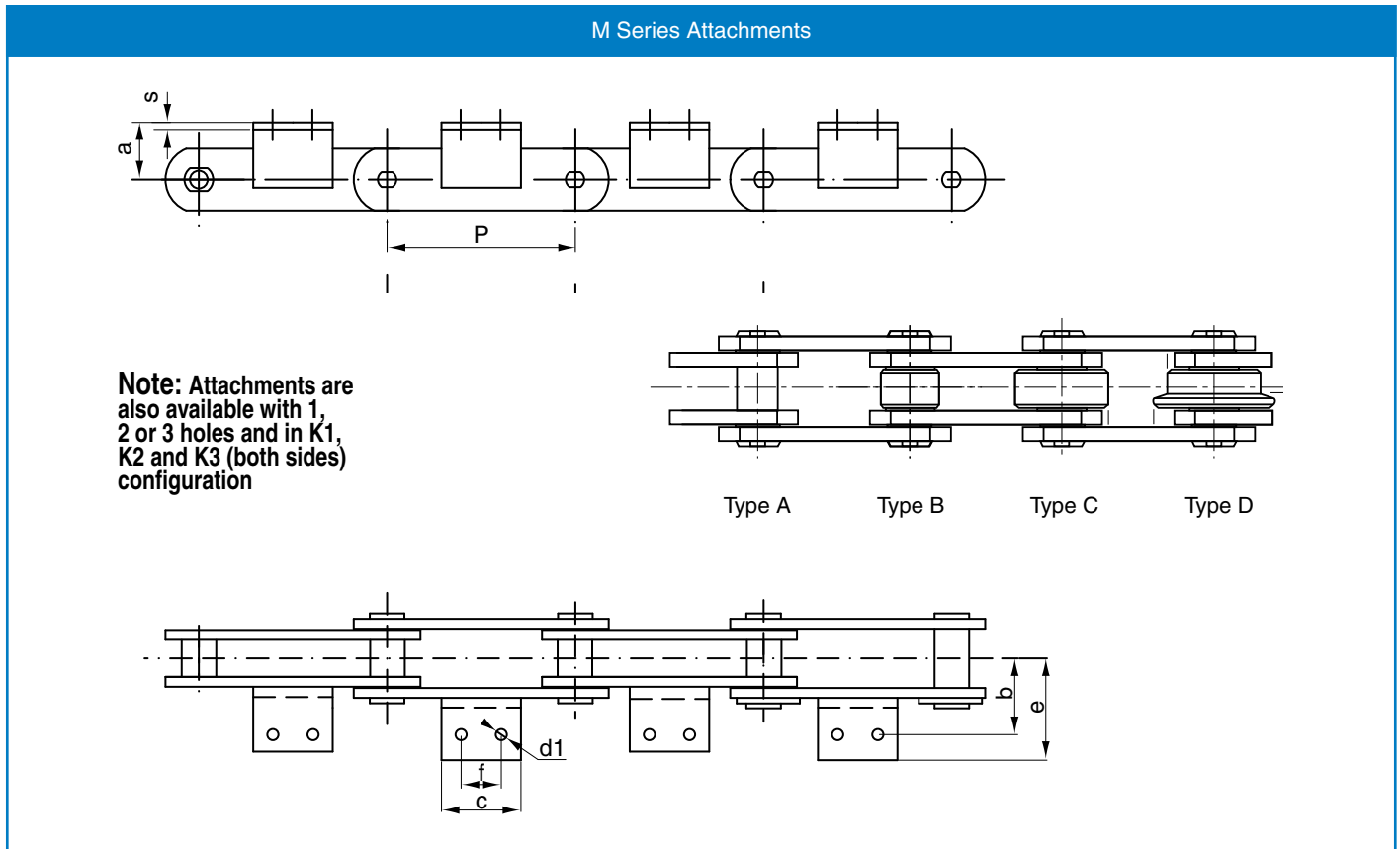

Chain Number	Pitch P	a	b	c	d1	e	f	Welded or Integral attachment	Chain Weight - Excluding Attachments kg/metre				Attachment Weight (A2) kg each
									Type A	Type B	Type C	Type D	
M 20	40	16	27	14	6.6	40	*	#	1.10	1.3	2.4	2.5	0.02
"	50	"	"	14	"	"	*	#	1.01	1.3	2.0	2.1	0.02
"	63	"	"	35	"	"	20	25x3	0.99	1.2	1.8	1.9	0.04
"	80	"	"	50	"	"	35	"	0.90	1.1	1.6	1.6	0.06
M 28	50	20	32	20	9	47	*	20x3	1.60	1.9	3.3	3.4	0.02
"	63	"	"	20	"	"	*	30x3	1.50	1.7	2.8	2.9	0.02
"	80	"	"	45	"	"	25	"	1.40	1.6	2.5	2.6	0.05
"	100	"	"	60	"	"	40	"	1.30	1.5	2.1	2.2	0.08
M 40	63	25	35	31	9	50	*	# 30x4	2.25	2.6	4.4	4.6	0.04
"	80	"	"	45	"	"	20	# "	2.00	2.3	3.7	3.9	0.07
"	100	"	"	60	"	"	40	# "	1.90	2.1	3.2	3.4	0.10
"	125	"	"	85	"	"	65	"	1.80	2.0	2.9	3.0	0.15
M 56	63	30	44	22	11	61	*	40x4	3.40	3.9	6.8	7.2	0.05
"	80	"	"	30	"	"	*	"	3.00	3.4	5.7	6.0	0.07
"	100	"	"	50	"	"	25	"	2.80	3.1	5.0	5.2	0.12
"	125	"	"	75	"	"	50	"	2.60	2.9	4.4	4.5	0.18
"	160	"	"	110	"	"	85	"	2.54	2.7	3.9	4.1	0.27
M 80	80	35	48	30	11	65	*	# 40x4	4.70	5.4	9.2	9.4	0.07
"	100	"	"	50	"	"	25	# "	4.30	4.8	7.9	8.0	0.12
"	125	"	"	75	"	"	50	# "	4.00	4.4	6.9	7.0	0.18
"	160	"	"	110	"	"	85	# "	3.70	4.0	6.0	6.1	0.27
"	200	"	"	150	"	"	125	# "	3.50	3.8	5.3	5.4	0.36

* Attachment With One Hole
Integral Attachment

All dimensions in millimetres unless otherwise stated. Every effort has been taken to ensure that the data listed in this catalogue is correct. Challenge accepts no liability for any inaccuracies or damage caused.

Conveyor Chain Attachments

M Series Attachments

Metric Conveyor Chain (DIN 8167)

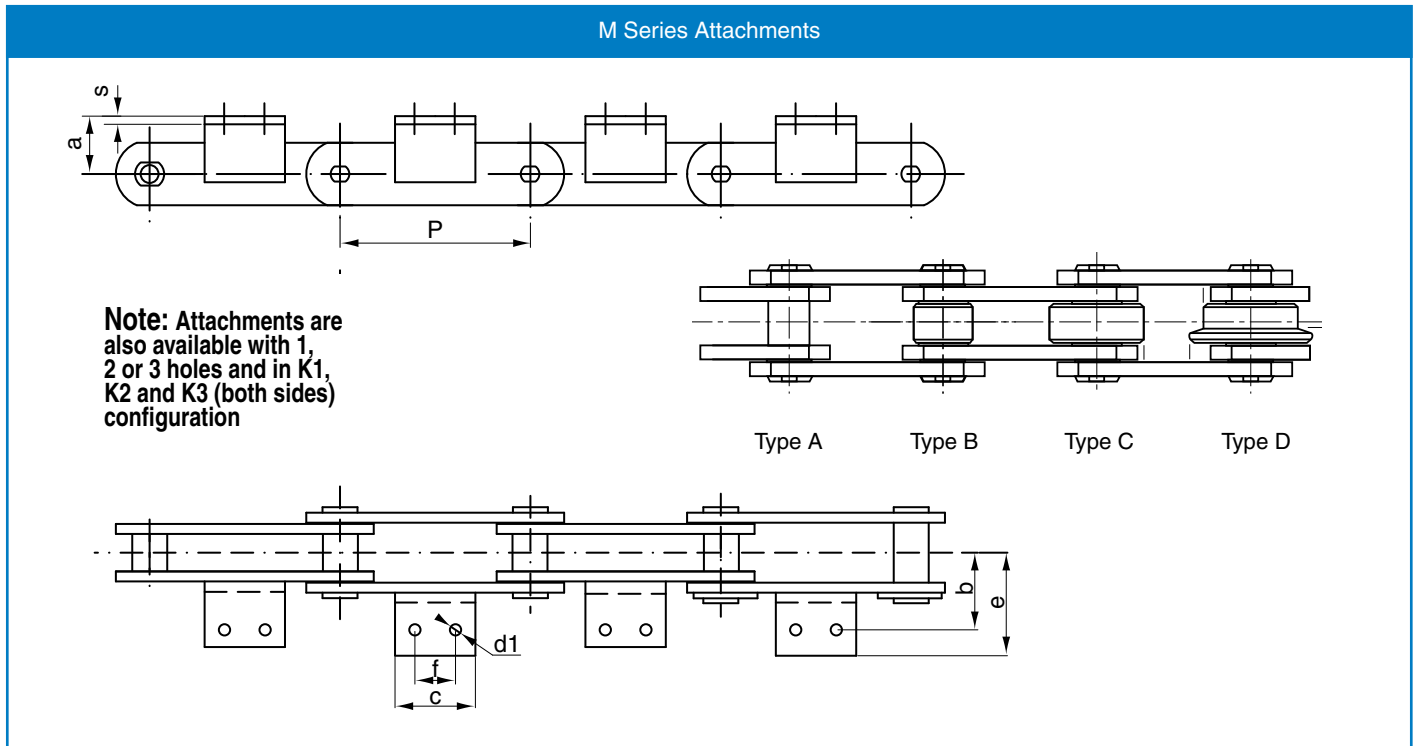

Chain Number	Pitch P	a	b	c	d1	e	f	Welded or Integral attachment	Chain Weight - Excluding Attachments kg/metre				Attachment Weight (A2) kg each
									Type A	Type B	Type C	Type D	
M 112	80	40	55	28	14	80	*	50x6	6.8	8.0	14.0	14.7	0.13
"	100	"	"	40	"	"	*	"	6.2	7.2	12.0	12.5	0.18
"	125	"	"	65	"	"	35	"	5.7	6.5	10.4	10.8	0.30
"	160	"	"	95	"	"	65	"	5.3	5.9	9.0	9.3	0.44
"	200	"	"	130	"	"	100	"	5.0	5.5	7.9	8.2	0.59
M 160	100	45	62	30	14	85	*	50x6	9.7	11.2	18.9	20.2	0.13
"	125	"	"	50	"	"	25	"	8.9	10.0	16.3	18.1	0.23
"	160	"	"	80	"	"	50	"	8.2	9.1	14.0	15.4	0.37
"	200	"	"	115	"	"	85	"	7.6	8.4	12.2	13.4	0.53
"	250	"	"	175	"	"	145	"	7.3	7.9	11.0	12.0	0.80
M 224	125	55	70	35	18	100	*	60x8	13.0	14.8	25.8	26.6	0.30
"	160	"	"	60	"	"	*	"	12.0	13.4	22.0	22.7	0.43
"	200	"	"	100	"	"	65	"	11.0	12.1	19.0	19.5	0.71
"	250	"	"	160	"	"	125	"	10.3	11.2	16.7	17.1	1.13
"	315	"	"	230	"	"	190	"	9.8	10.5	14.9	15.2	1.60
M 315	160	65	80	35	18	115	*	70x9	18.3	20.4	33.3	34.6	0.32
"	200	"	"	85	"	"	50	"	16.7	18.4	28.7	29.7	0.66
"	250	"	"	140	"	"	100	"	15.6	17.0	25.2	26.0	1.10
"	315	"	"	190	"	"	155	"	14.6	15.7	22.3	22.9	1.46
"	400	"	"	205	"	"	155	"	13.9	14.8	20.0	20.5	1.46

Every effort has been taken to ensure that the data listed in this catalogue is correct. Challenge accepts no liability for any inaccuracies or damage caused. All dimensions in millimetres unless otherwise stated.

Conveyor Chain Attachments

M Series Attachments

Metric Conveyor Chain (DIN 8167)

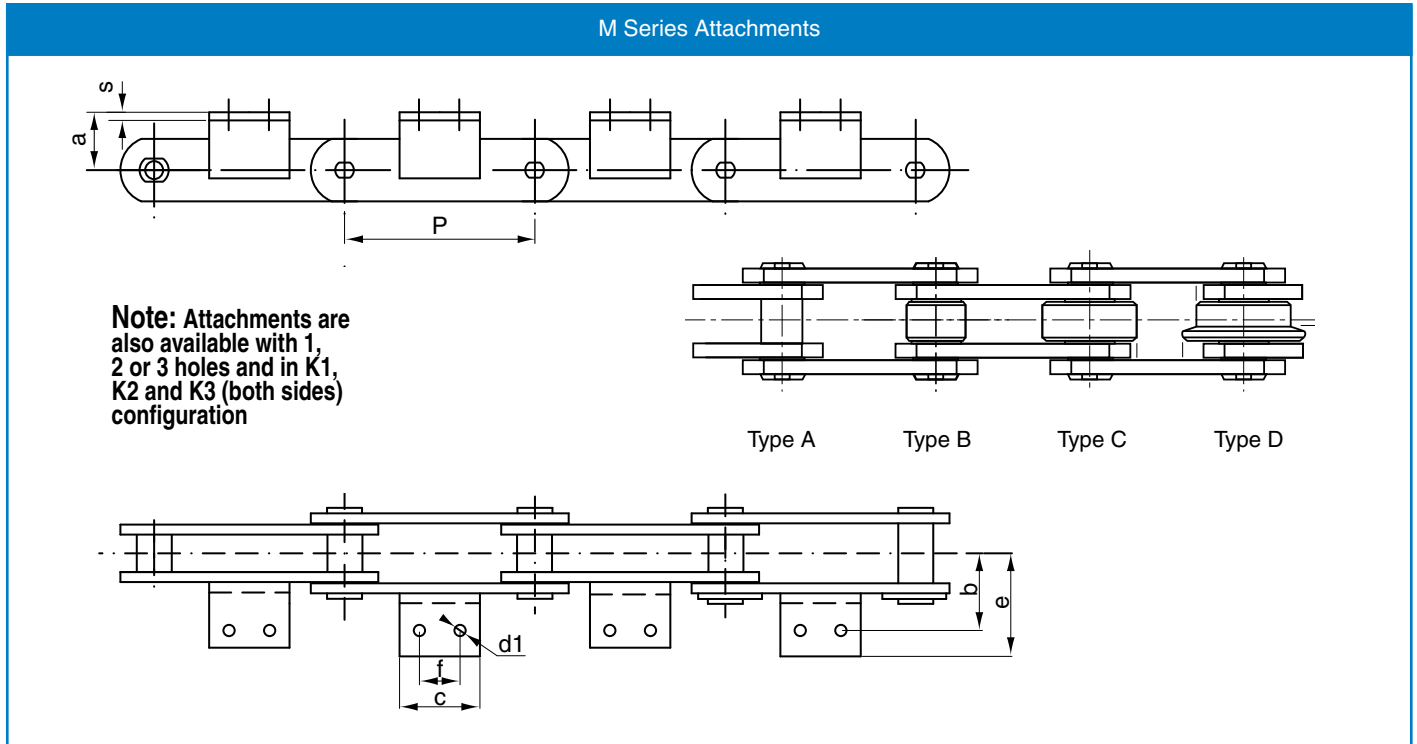

Chain Number	Pitch P	a	b	c	d1	e	f	Welded or Integral attachment	Chain Weight - Excluding Attachments kg/metre				Attachment Weight (A2) kg each
									Type A	Type B	Type C	Type D	
M 450	200	75	90	50	18	125	*	70x9	24.0	27.0	40.5	47.0	0.33
"	250	"	"	125	"	"	85	"	22.0	24.9	39.5	41.0	1.00
"	315	"	"	195	"	"	155	"	21.0	23.0	34.5	36.0	1.60
"	400	"	"	280	"	"	240	"	19.6	21.2	30.5	31.4	2.30
M 630	250	90	115	50	24	165	*	100x12	36.0	40.8	64.0	66.9	0.90
"	315	"	"	150	"	"	100	"	33.4	36.6	55.5	57.7	2.70
"	400	"	"	240	"	"	190	"	31.5	33.9	49.0	50.7	4.30
"	500	"	"	350	"	"	300	"	29.6	31.6	43.6	45.0	6.20
M 900	250	110	140	60	30	195	*	120x15	49.7	56.5	98.3	104.5	1.60
"	315	"	"	125	"	"	65	"	45.5	51.8	84.2	89.7	3.30
"	400	"	"	215	"	"	155	"	42.0	46.2	72.5	76.9	5.70
"	500	"	"	300	"	"	240	"	39.3	42.7	63.8	67.6	8.00
"	600	"	"	350	"	"	300	"	37.3	39.9	56.6	58.9	8.00

* Attachment With One Hole

Conveyor Chain

MC Series Hollow pin

Metric Conveyor Chain (DIN 8167)

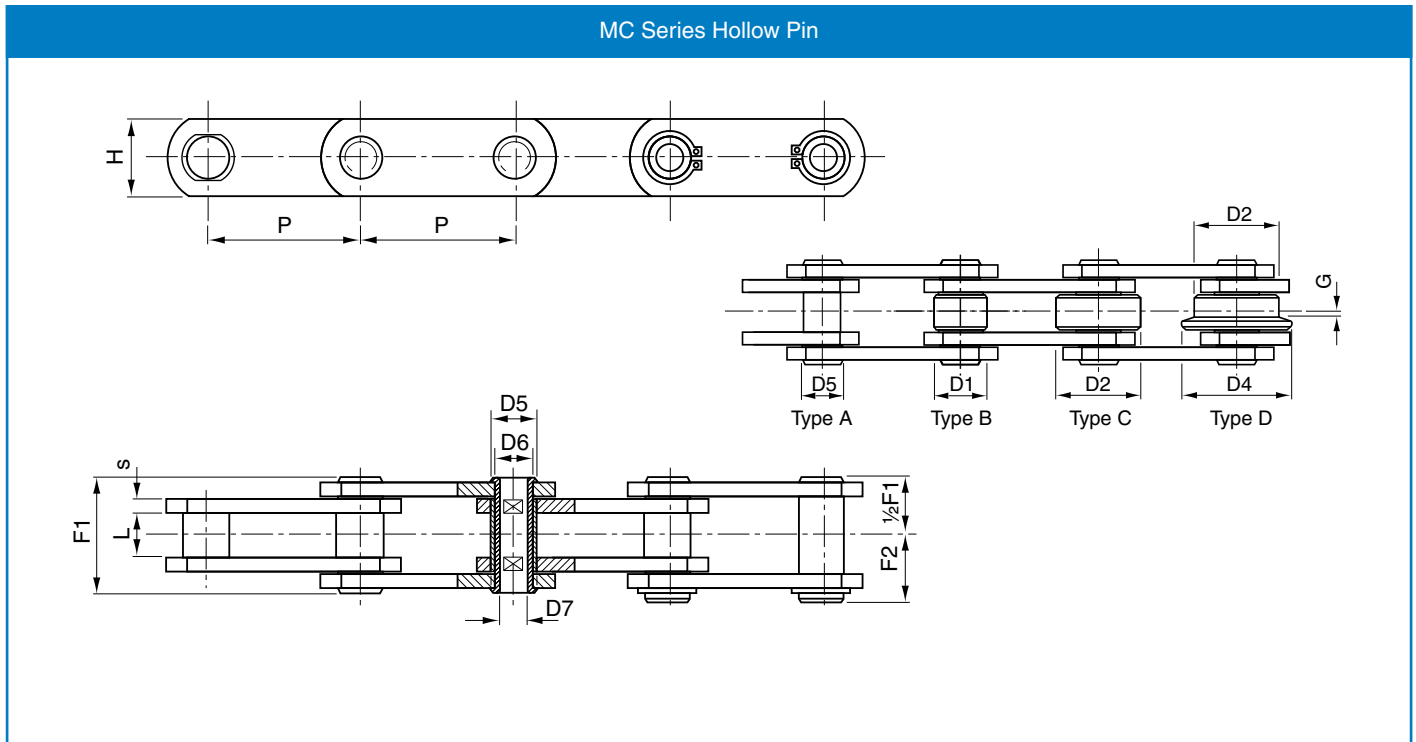

Hollow Pin

Chain number	Pitch P	L	G	H	S	F1	F2	D1	D2	D4	D5	D6	D7	Breaking Load kN	Weight (Type C) kg/m
MC 28	50	20	4.5	25	3	36.0	20.5	25	36	45	17	13.0	8.2	28	4.3
"	63	"	"	"	"	"	"	"	"	"	"	"	"	"	3.8
"	80	"	"	"	"	"	"	"	"	"	"	"	"	"	3.2
"	100	"	"	"	"	"	"	"	"	"	"	"	"	"	2.8
"	125	"	"	"	"	"	"	"	"	"	"	"	"	"	2.5
MC 56	63	24	7.0	35	4	45.0	25.0	30	50	60	21	15.5	10.2	56	8.5
"	80	"	"	"	"	"	"	"	"	"	"	"	"	"	7.2
"	100	"	"	"	"	"	"	"	"	"	"	"	"	"	6.2
"	125	"	"	"	"	"	"	"	"	"	"	"	"	"	5.4
"	160	"	"	"	"	"	"	"	"	"	"	"	"	"	4.7
MC 112	80	32	8.5	50	6	62.5	33.0	42	70	85	29	22.0	14.3	112	16.6
"	100	"	"	"	"	"	"	"	"	"	"	"	"	"	14.0
"	125	"	"	"	"	"	"	"	"	"	"	"	"	"	11.2
"	160	"	"	"	"	"	"	"	"	"	"	"	"	"	10.2
"	200	"	"	"	"	"	"	"	"	"	"	"	"	"	8.9
"	250	"	"	"	"	"	"	"	"	"	"	"	"	"	7.9
MC 224	125	43	10.5	70	8	83.0	44.0	60	100	120	42	30.0	20.3	224	32.3
"	160	"	"	"	"	"	"	"	"	"	"	"	"	"	27.1
"	200	"	"	"	"	"	"	"	"	"	"	"	"	"	23.5
"	250	"	"	"	"	"	"	"	"	"	"	"	"	"	20.6
"	315	"	"	"	"	"	"	"	"	"	"	"	"	"	17.2

Conveyor Chain

MT/ME Series Deep Link

Metric Conveyor Chain (DIN 8167)

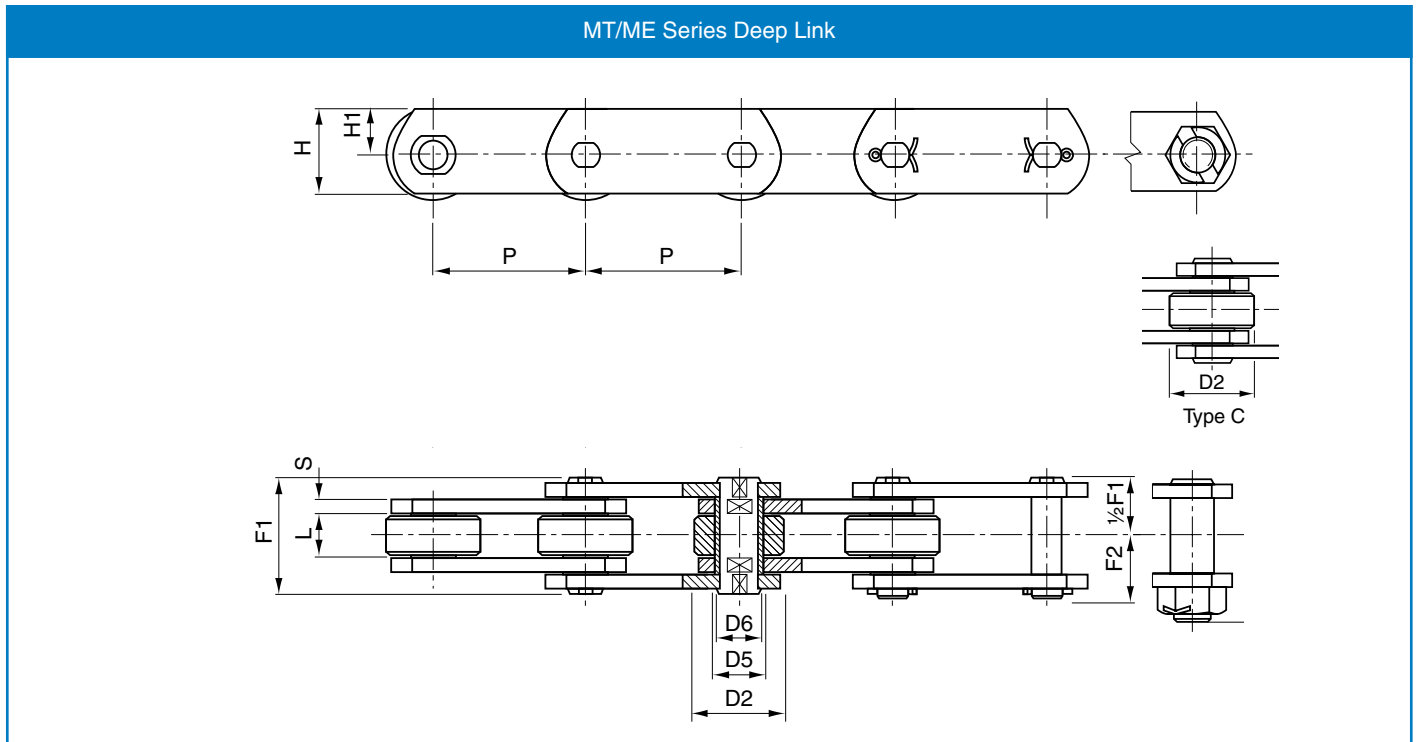

Deep Link

Chain Number	Pitch P	L	S	H	H1	F1	F2	D2	D5	D6	Breaking Load kN	Weight (Type C) kg/m
ME 20	40	16	2.5	25	16.0	33.0	19.0	25	9	6	20	3.0
"	50	"	"	"	"	"	"	"	"	"	"	2.6
"	63	"	"	"	"	"	"	"	"	"	"	2.3
"	80	"	"	"	"	"	"	"	"	"	"	2.0
ME 28	50	18	3.0	30	20.0	36.0	20.5	30	10	7	28	4.1
"	63	"	"	"	"	"	"	"	"	"	"	3.5
"	80	"	"	"	"	"	"	"	"	"	"	3.1
"	100	"	"	"	"	"	"	"	"	"	"	2.8
ME 40	63	20	4.0	35	22.5	40.5	24.0	36	11	8	40	5.5
"	80	"	"	"	"	"	"	"	"	"	"	4.8
"	100	"	"	"	"	"	"	"	"	"	"	4.2
"	125	"	"	"	"	"	"	"	"	"	"	3.7
ME 56	63	24	4.0	45	30.0	45.0	26.0	42	15	10	56	8.3
"	80	"	"	"	"	"	"	"	"	"	"	7.0
"	100	"	"	"	"	"	"	"	"	"	"	6.1
"	125	"	"	"	"	"	"	"	"	"	"	5.4
ME 80	80	28	5.0	50	32.5	54.5	30.5	50	18	12	80	11.0
"	100	"	"	"	"	"	"	"	"	"	"	9.5
"	125	"	"	"	"	"	"	"	"	"	"	8.5
"	160	"	"	"	"	"	"	"	"	"	"	7.2
"	200	"	"	"	"	"	"	"	"	"	"	6.0

All dimensions in millimetres unless otherwise stated. Every effort has been taken to ensure that the data listed in this catalogue is correct. Challenge accepts no liability for any inaccuracies or damage caused.

Conveyor Chain

MT/ME Series

Metric Conveyor Chain (DIN 8167)

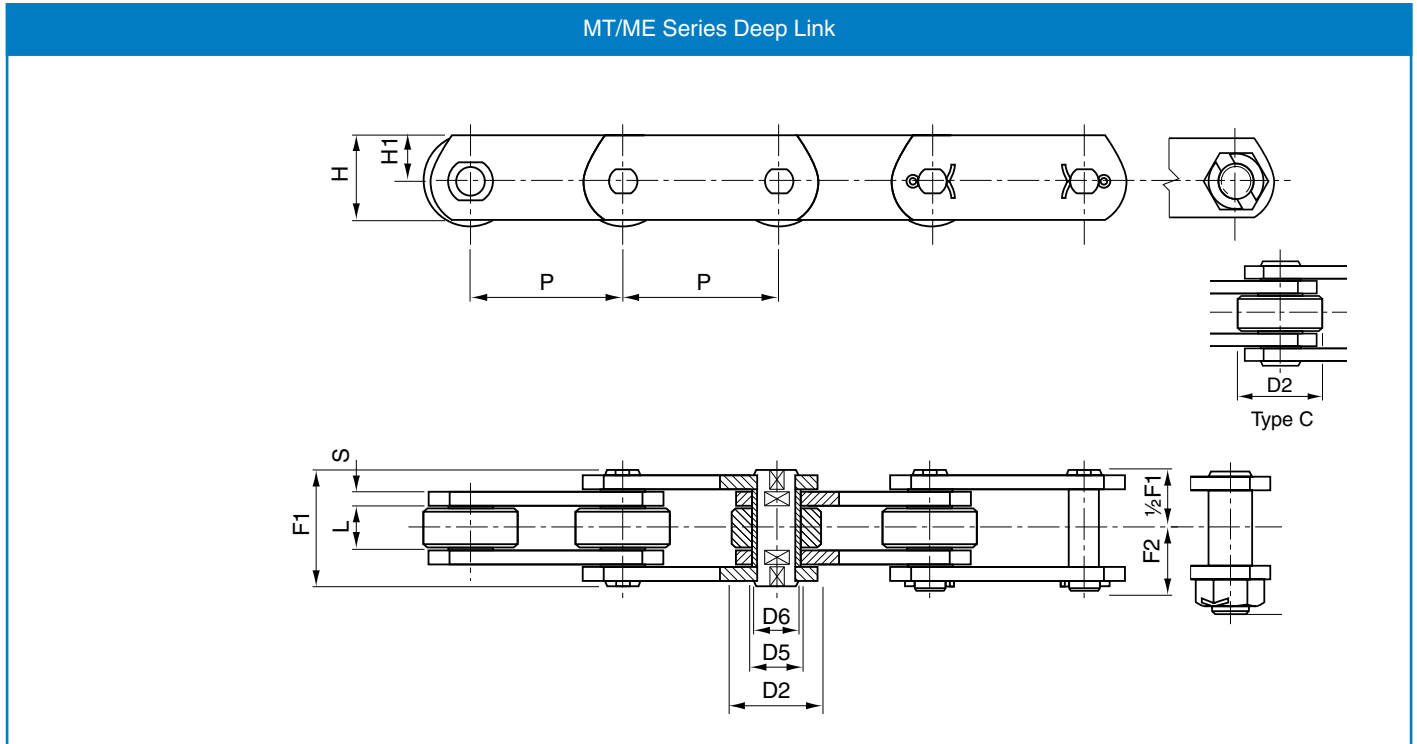

Deep Link

Chain Number	Pitch P	L	S	H	H1	F1	F2	D2	D5	D6	Breaking Load kN	Weight kg/m
ME 112	80	32	6	60	40	63	36.0	60	21	15	112	17.0
"	100	"	"	"	"	"	"	"	"	"	"	14.5
"	125	"	"	"	"	"	"	"	"	"	"	13.0
"	160	"	"	"	"	"	"	"	"	"	"	11.0
"	200	"	"	"	"	"	"	"	"	"	"	10.0
ME 160	100	37	7	70	45	72	41.5	70	25	18	160	21.5
"	125	"	"	"	"	"	"	"	"	"	"	19.0
"	160	"	"	"	"	"	"	"	"	"	"	17.0
"	200	"	"	"	"	"	"	"	"	"	"	15.0
"	250	"	"	"	"	"	"	"	"	"	"	13.5
ME 224	125	43	8	90	60	84	47.0	85	30	21	224	32.5
"	160	"	"	"	"	"	"	"	"	"	"	27.5
"	200	"	"	"	"	"	"	"	"	"	"	23.0
"	250	"	"	"	"	"	"	"	"	"	"	21.0
"	315	"	"	"	"	"	"	"	"	"	"	19.0
ME 315	160	48	10	100	65	97	55.0	100	36	25	315	43.0
"	200	"	"	"	"	"	"	"	"	"	"	37.0
"	250	"	"	"	"	"	"	"	"	"	"	32.0
"	315	"	"	"	"	"	"	"	"	"	"	28.6
"	400	"	"	"	"	"	"	"	"	"	"	25.5

Conveyor Chain

MT/ME Series

Metric Conveyor Chain (DIN 8167)

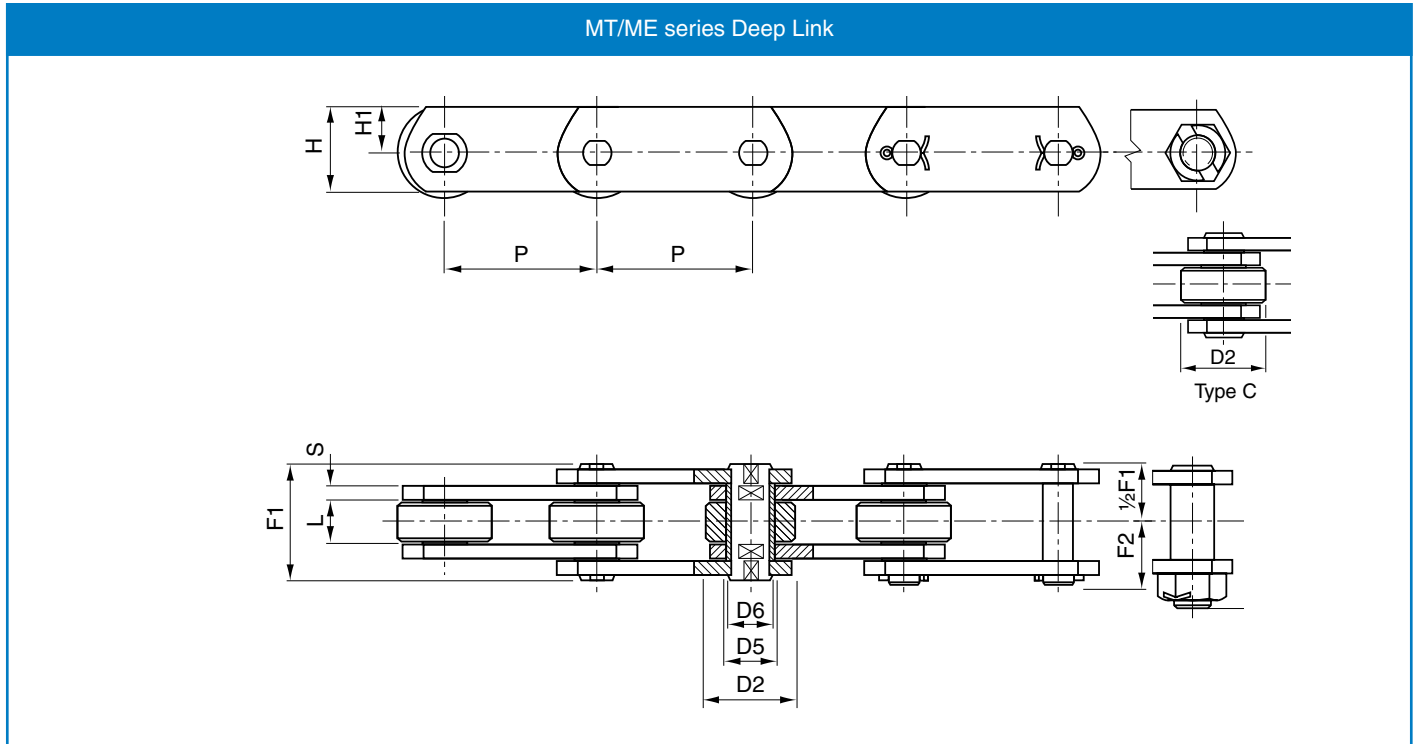

Deep Link

Chain Number	Pitch P	L	S	H	H1	F1	F2	D2	D5	D6	Breaking Load kN	Weight kg/m
ME 450	200	56	12	120	80	114	67.0	120	42	30	450	700
"	250	"	"	"	"	"	"	"	"	"	"	"
"	315	"	"	"	"	"	"	"	"	"	"	"
"	400	"	"	"	"	"	"	"	"	"	"	"
ME 630	250	66	14	140	90	137	87.5	140	50	36	630	900
"	315	"	"	"	"	"	"	"	"	"	"	"
"	400	"	"	"	"	"	"	"	"	"	"	"
"	500	"	"	"	"	"	"	"	"	"	"	"
"	600	"	"	"	"	"	"	"	"	"	"	"
ME 900	250	78	16	180	120	153	95.0	170	60	44	900	1,250
"	315	"	"	"	"	"	"	"	"	"	"	"
"	400	"	"	"	"	"	"	"	"	"	"	"
"	500	"	"	"	"	"	"	"	"	"	"	"
"	600	"	"	"	"	"	"	"	"	"	"	"

All dimensions in millimetres unless otherwise stated. Every effort has been taken to ensure that the data listed in this catalogue is correct. Challenge accepts no liability for any inaccuracies or damage caused.

Conveyor Chain

FV/C Series

Metric Conveyor Chain (DIN 8165)

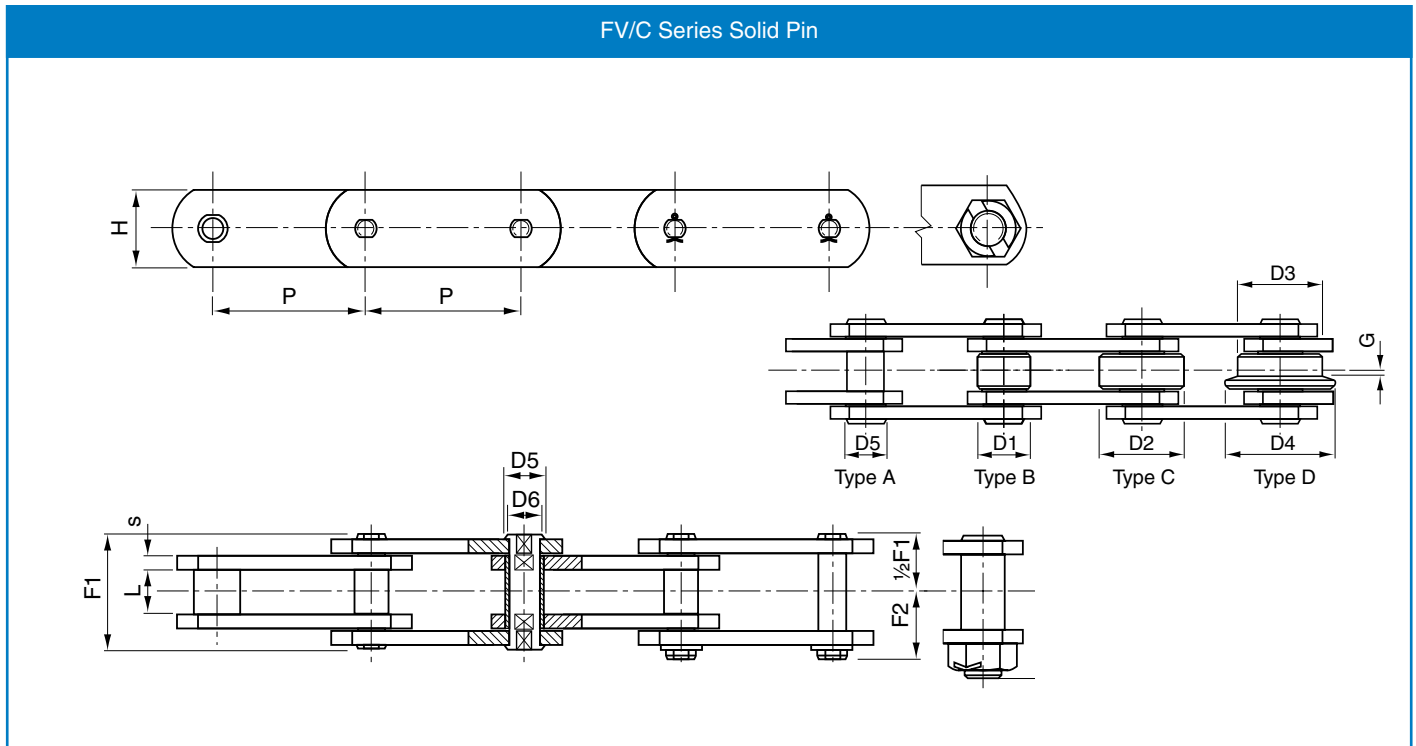

Solid Pin

DIN Number	Chain number	Pitch P	L	G	H	S	F1	F2	D1	D2	D3	D4	D5	D6	Breaking Load kN	Weight (Type C) kg/m
FV40	C42	50	18	4	25	3	36	21	20	32	40	50	15	10	42	4.0
"	"	63	"	"	"	"	"	"	"	"	"	"	"	"	"	3.3
"	"	80	"	"	"	"	"	"	"	"	"	"	"	"	"	3.0
"	"	100	"	"	"	"	"	"	"	"	"	"	"	"	"	2.6
"	"	125	"	"	"	"	"	"	"	"	"	"	"	"	"	2.3
FV63	C64	63	22	5	30	4	45	26	26	40	50	63	18	12	64	6.4
"	"	80	"	"	"	"	"	"	"	"	"	"	"	"	"	5.3
"	"	100	"	"	"	"	"	"	"	"	"	"	"	"	"	4.7
"	"	125	"	"	"	"	"	"	"	"	"	"	"	"	"	4.0
"	"	160	"	"	"	"	"	"	"	"	"	"	"	"	"	3.5
FV90	C100	63	25	6.5	35	5	53	30	30	48	63	78	20	14	100	10.0
"	"	80	"	"	"	"	"	"	"	"	"	"	"	"	"	8.6
"	"	100	"	"	"	"	"	"	"	"	"	"	"	"	"	7.3
"	"	125	"	"	"	"	"	"	"	"	"	"	"	"	"	6.5
"	"	160	"	"	"	"	"	"	"	"	"	"	"	"	"	5.8
"	"	200	"	"	"	"	"	"	"	"	"	"	"	"	"	4.8
"	"	250	"	"	"	"	"	"	"	"	"	"	"	"	"	4.6
FV112	C120	100	30	7.5	40	6	62	35	32	55	72	90	22	16	120	11.2
"	"	125	"	"	"	"	"	"	"	"	"	"	"	"	"	9.6
"	"	160	"	"	"	"	"	"	"	"	"	"	"	"	"	8.3
"	"	200	"	"	"	"	"	"	"	"	"	"	"	"	"	7.5
"	"	250	"	"	"	"	"	"	"	"	"	"	"	"	"	6.7

Every effort has been taken to ensure that the data listed in this catalogue is correct. Challenge accepts no liability for any inaccuracies or damage caused. All dimensions in millimetres unless otherwise stated.

Conveyor Chain

FV/C Series

Metric Conveyor Chain (DIN 8165)

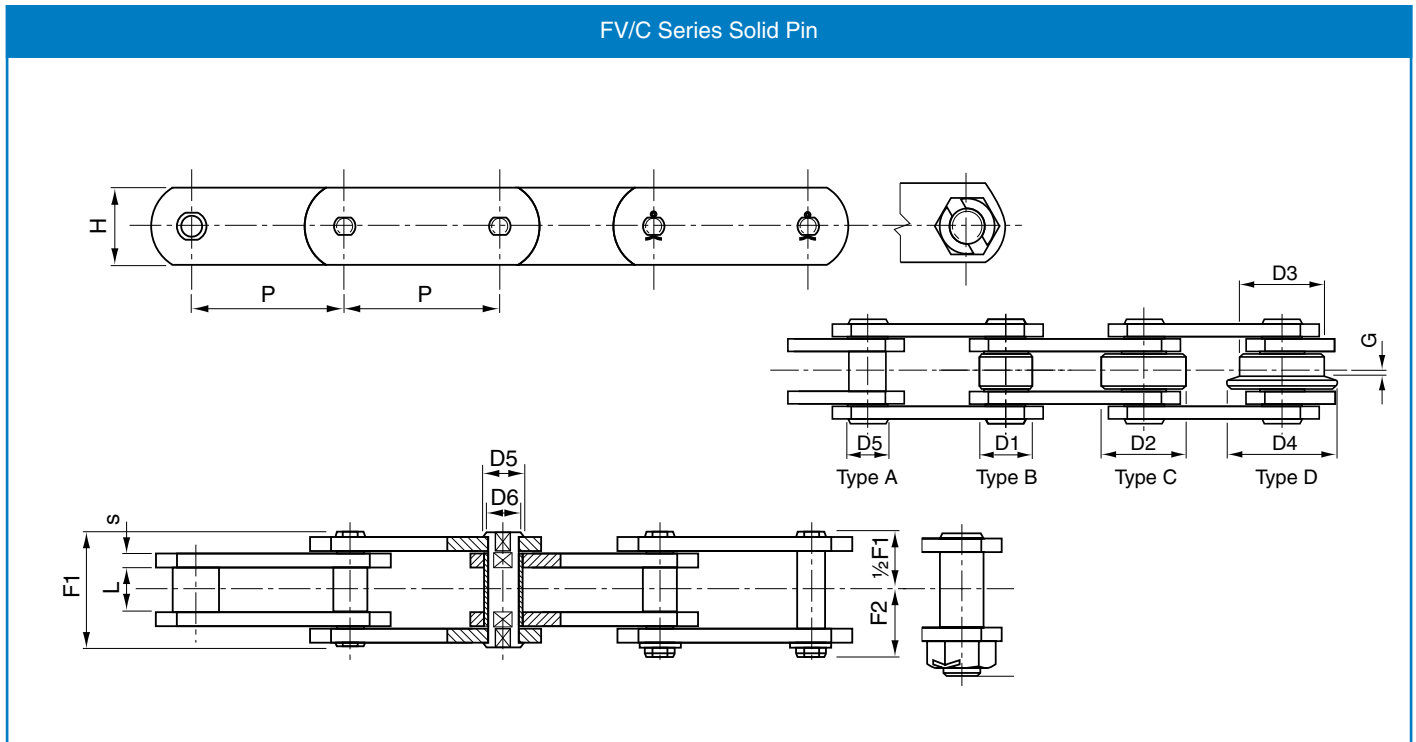

Solid Pin

DIN Number	Chain number	Pitch P	L	G	H	S	F1	F2	D1	D2	D3	D4	D5	D6	Breaking Load kN	Weight (Type C) kg/m
FV140	C145	100	35	9	45	6	67	38	36	60	80	100	26	18	145	14.3
"	"	125	"	"	"	"	"	"	"	"	"	"	"	"	"	12.3
"	"	160	"	"	"	"	"	"	"	"	"	"	"	"	"	10.5
"	"	200	"	"	"	"	"	"	"	"	"	"	"	"	"	9.0
"	"	250	"	"	"	"	"	"	"	"	"	"	"	"	"	8.3
FV180	C190	125	45	13	50	8	86	49	42	70	100	125	30	20	190	18.9
"	"	160	"	"	"	"	"	"	"	"	"	"	"	"	"	16.7
"	"	200	"	"	"	"	"	"	"	"	"	"	"	"	"	14.8
"	"	250	"	"	"	"	"	"	"	"	"	"	"	"	"	13.0
"	"	315	"	"	"	"	"	"	"	"	"	"	"	"	"	11.6
FV250	C275	160	55	15	60	8	97	55	50	80	125	155	36	26	275	23.8
"	"	200	"	"	"	"	"	"	"	"	"	"	"	"	"	20.6
"	"	250	"	"	"	"	"	"	"	"	"	"	"	"	"	17.9
"	"	315	"	"	"	"	"	"	"	"	"	"	"	"	"	15.8
"	"	400	"	"	"	"	"	"	"	"	"	"	"	"	"	13.9
FV315	C370	160	65	18	70	10	113	70	60	90	140	175	42	30	370	33.3
"	"	200	"	"	"	"	"	"	"	"	"	"	"	"	"	28.9
"	"	250	"	"	"	"	"	"	"	"	"	"	"	"	"	25.3
"	"	315	"	"	"	"	"	"	"	"	"	"	"	"	"	22.4
"	"	400	"	"	"	"	"	"	"	"	"	"	"	"	"	20.2

All dimensions in millimetres unless otherwise stated. Every effort has been taken to ensure that the data listed in this catalogue is correct. Challenge accepts no liability for any inaccuracies or damage caused.

Conveyor Chain

FV/CC Series

Metric Conveyor Chain (DIN 8165)

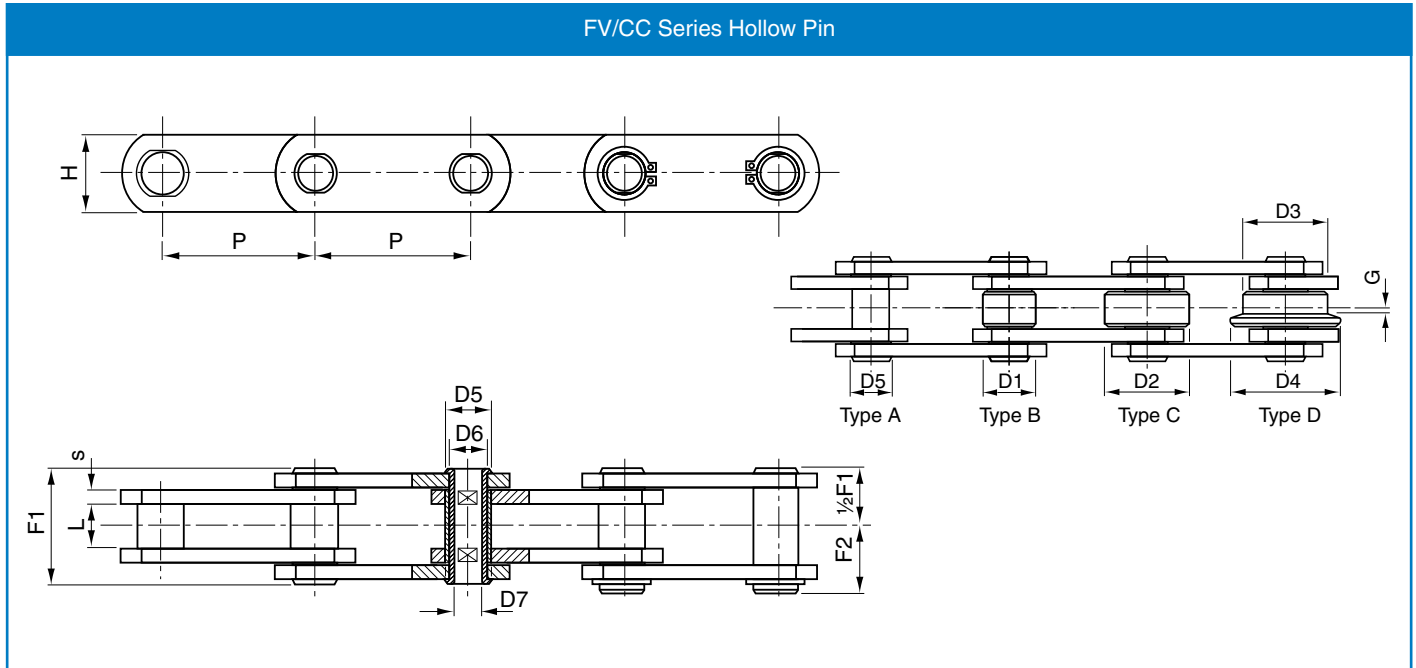

Hollow Pin

DIN Number	Chain number	Pitch P	L	G	H	S	F1	F2	D1	D2	D3	D4	D5	D6	D7	Breaking Load kN	Weight (Type C) kg/m
FV63	CC46	63	22	5	30	4	45	28	26	40	50	63	18	12	8	46	5.7
"	"	80	"	"	"	"	"	"	"	"	"	"	"	"	"	"	4.9
"	"	100	"	"	"	"	"	"	"	"	"	"	"	"	"	"	4.3
"	"	125	"	"	"	"	"	"	"	"	"	"	"	"	"	"	3.8
"	"	160	"	"	"	"	"	"	"	"	"	"	"	"	"	"	3.4
FV90	CC73	63	25	6.5	35	5	53	30	30	48	63	78	20	14	10	73	9.1
"	"	80	"	"	"	"	"	"	"	"	"	"	"	"	"	"	7.8
"	"	100	"	"	"	"	"	"	"	"	"	"	"	"	"	"	6.8
"	"	125	"	"	"	"	"	"	"	"	"	"	"	"	"	"	5.6
"	"	160	"	"	"	"	"	"	"	"	"	"	"	"	"	"	5.3
"	"	200	"	"	"	"	"	"	"	"	"	"	"	"	"	"	4.7
"	"	250	"	"	"	"	"	"	"	"	"	"	"	"	"	"	4.3
FV112	CC90	100	30	7.5	40	6	62	32	32	55	72	90	22	16	11	90	10.2
"	"	125	"	"	"	"	"	"	"	"	"	"	"	"	"	"	8.9
"	"	160	"	"	"	"	"	"	"	"	"	"	"	"	"	"	7.8
"	"	200	"	"	"	"	"	"	"	"	"	"	"	"	"	"	7.0
"	"	250	"	"	"	"	"	"	"	"	"	"	"	"	"	"	6.3
FV140	CC110	100	35	9	45	6	67	35	36	60	80	100	26	18	12	110	12.9
"	"	125	"	"	"	"	"	"	"	"	"	"	"	"	"	"	11.2
"	"	160	"	"	"	"	"	"	"	"	"	"	"	"	"	"	9.7
"	"	200	"	"	"	"	"	"	"	"	"	"	"	"	"	"	8.6
"	"	250	"	"	"	"	"	"	"	"	"	"	"	"	"	"	7.7

Every effort has been taken to ensure that the data listed in this catalogue is correct. Challenge accepts no liability for any inaccuracies or damage caused. All dimensions in millimetres unless otherwise stated.

Conveyor Chain

FV/CC Series

Metric Conveyor Chain (DIN 8165)

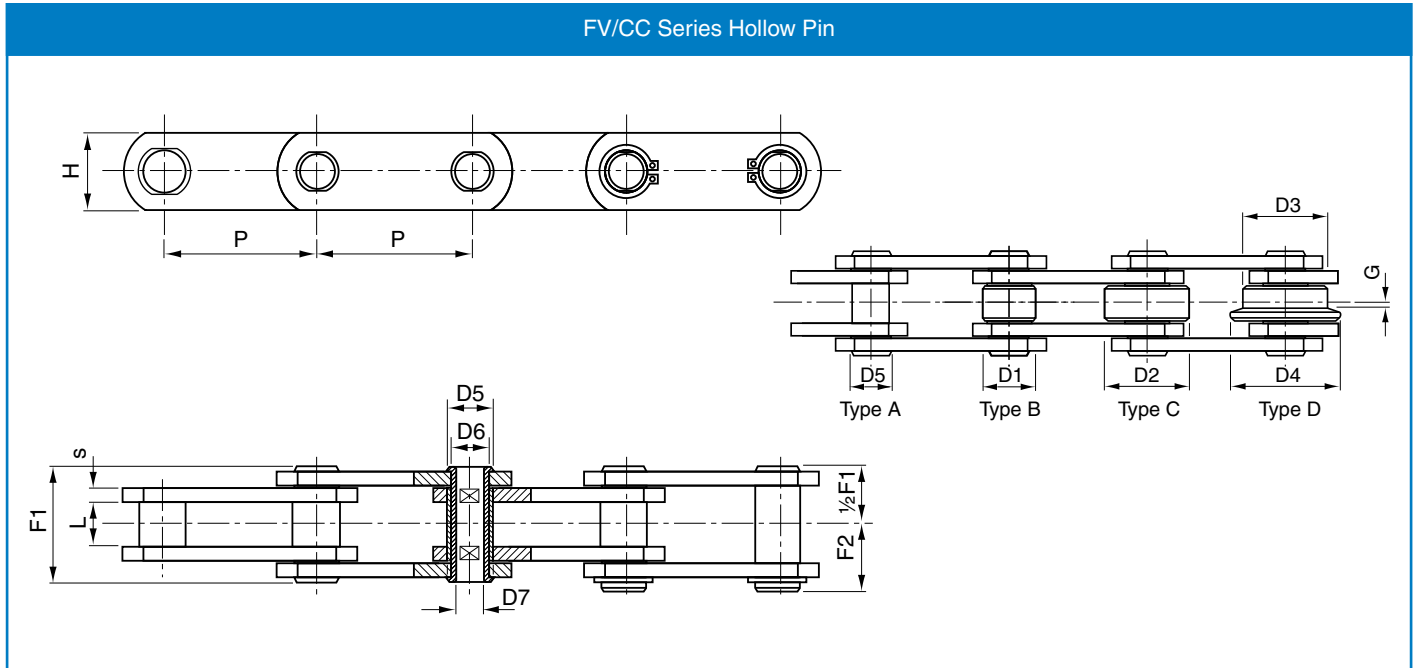

Hollow Pin

DIN Number	Chain number	Pitch P	L	G	H	S	F1	F2	D1	D2	D3	D4	D5	D6	D7	Breaking Load kN	Weight (Type C) kg/m
FV180	CC145	125	45	13	50	8	86	45	42	70	100	125	30	20	14	145	18.2
"	"	160	"	"	"	"	"	"	"	"	"	"	"	"	"	"	15.6
"	"	200	"	"	"	"	"	"	"	"	"	"	"	"	"	"	13.8
"	"	250	"	"	"	"	"	"	"	"	"	"	"	"	"	"	12.3
"	"	315	"	"	"	"	"	"	"	"	"	"	"	"	"	"	11.0
FV250	CC215	160	55	15	60	8	97	55	50	80	125	155	36	26	18	215	20.5
"	"	200	"	"	"	"	"	"	"	"	"	"	"	"	"	"	18.0
"	"	250	"	"	"	"	"	"	"	"	"	"	"	"	"	"	15.9
"	"	315	"	"	"	"	"	"	"	"	"	"	"	"	"	"	14.2
FV315	CC295	160	65	18	70	10	117	63	60	90	140	175	42	30	20	295	34.1
"	"	200	"	"	"	"	"	"	"	"	"	"	"	"	"	"	29.5
"	"	250	"	"	"	"	"	"	"	"	"	"	"	"	"	"	25.8
"	"	315	"	"	"	"	"	"	"	"	"	"	"	"	"	"	22.8
"	"	400	"	"	"	"	"	"	"	"	"	"	"	"	"	"	20.2

All dimensions in millimetres unless otherwise stated. Every effort has been taken to ensure that the data listed in this catalogue is correct. Challenge accepts no liability for any inaccuracies or damage caused.

Conveyor Chain Attachments

FV Series Attachments

Metric Conveyor Chain (DIN 8165)

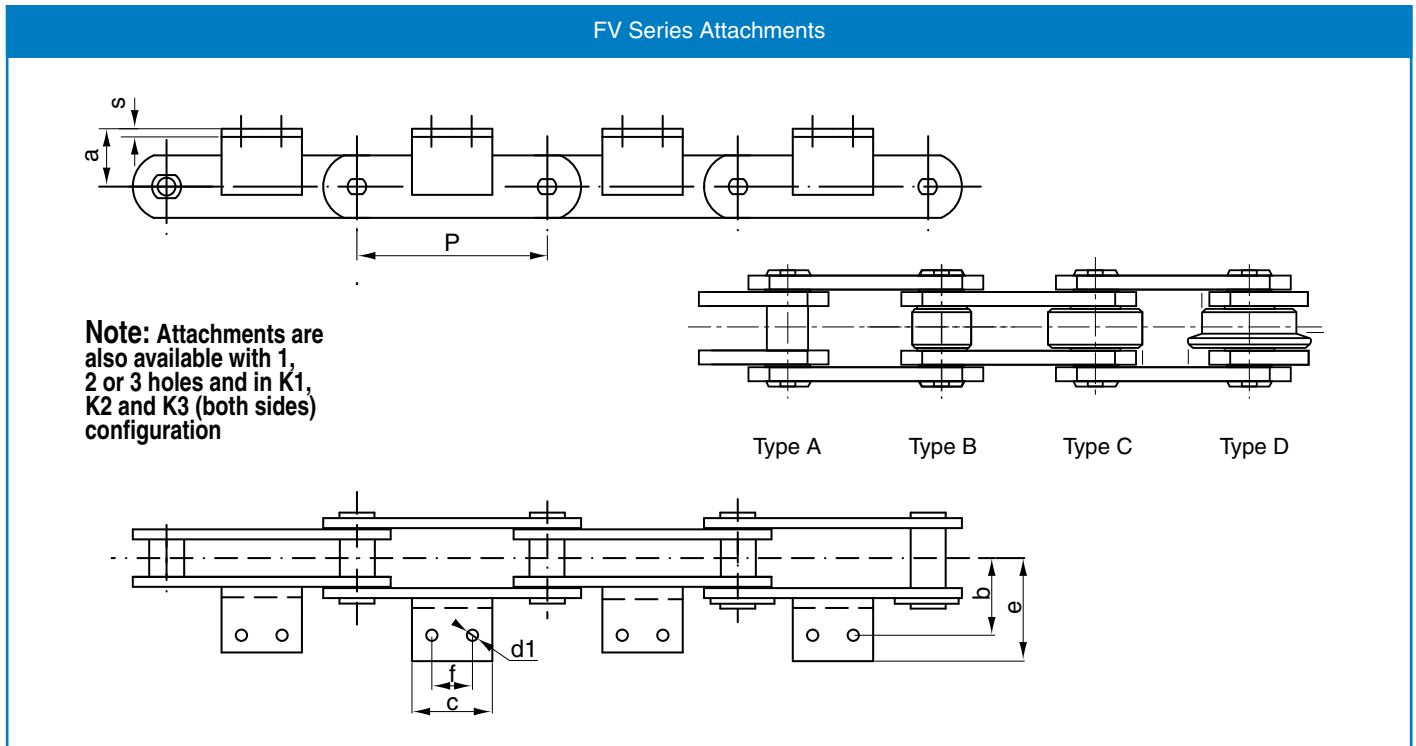

DIN Number	Chain Number	Pitch P	a	b	c	d1	e	f	Welded or Integral attachment	Chain Weight - Excluding Attachments kg/metre				Attachment Weight (A2) kg each
										Type A	Type B	Type C	Type D	
FV40	C42	50	20	25	45	6.5	64.0	*	#	2.4	2.9	4.0	5.6	0.050
"	"	63	"	"	31	"	40.5	*	#	2.0	2.4	3.3	4.5	0.036
"	"	80	"	"	45	"	"	25	# 25x3	1.9	2.2	3.0	3.9	0.050
"	"	100	"	"	50	"	"	30	# "	1.7	2.0	2.6	3.3	0.056
"	"	125	"	"	60	"	"	30	# "	1.6	1.9	2.3	3.0	0.067
FV63	C64	63	30	34	40	8.4	50.0	*	30x4	3.8	4.5	6.4	8.9	0.063
"	"	80	"	"	45	"	"	25	# "	3.2	3.8	5.3	7.2	0.095
"	"	100	"	"	50	"	"	30	"	3.0	3.5	4.7	6.2	0.110
"	"	125	"	"	60	"	"	40	"	2.7	3.0	4.0	5.3	0.140
"	"	160	"	"	70	"	"	50	"	2.4	2.7	3.5	4.4	0.170
FV90	C100	63	35	40	30	8.4	64.0	*	# 40x4	5.6	6.8	10.0	14.7	0.072
"	"	80	"	"	45	"	"	25	# "	5.1	6.0	8.6	12.3	0.110
"	"	100	"	"	50	"	"	30	# "	4.5	5.3	7.3	10.3	0.130
"	"	125	"	"	60	"	"	40	# "	4.2	4.8	6.5	8.8	0.160
"	"	160	"	"	70	"	"	50	# "	4.0	4.5	5.8	7.6	0.200
"	"	200	"	"	80	"	"	60	# "	3.5	3.8	4.8	5.8	0.240
"	"	250	"	"	85	"	"	65	# "	3.4	3.7	4.6	5.4	0.210
FV112	C120	100	40	50	50	11.0	70.0	30	40x6	6.7	7.7	11.2	18.8	0.200
"	"	125	"	"	65	"	"	40	"	6.0	6.8	9.6	15.7	0.270
"	"	160	"	"	75	"	"	50	"	5.5	6.1	8.3	13.0	0.310
"	"	200	"	"	90	"	"	65	"	5.2	5.7	7.5	11.3	0.400
"	"	250	"	"	105	"	"	80	"	4.9	5.3	6.7	9.8	0.500

* Attachment With One Hole

Integral Attachment

Conveyor Chain Attachments

FV Series Attachments

Metric Conveyor Chain (DIN 8165)

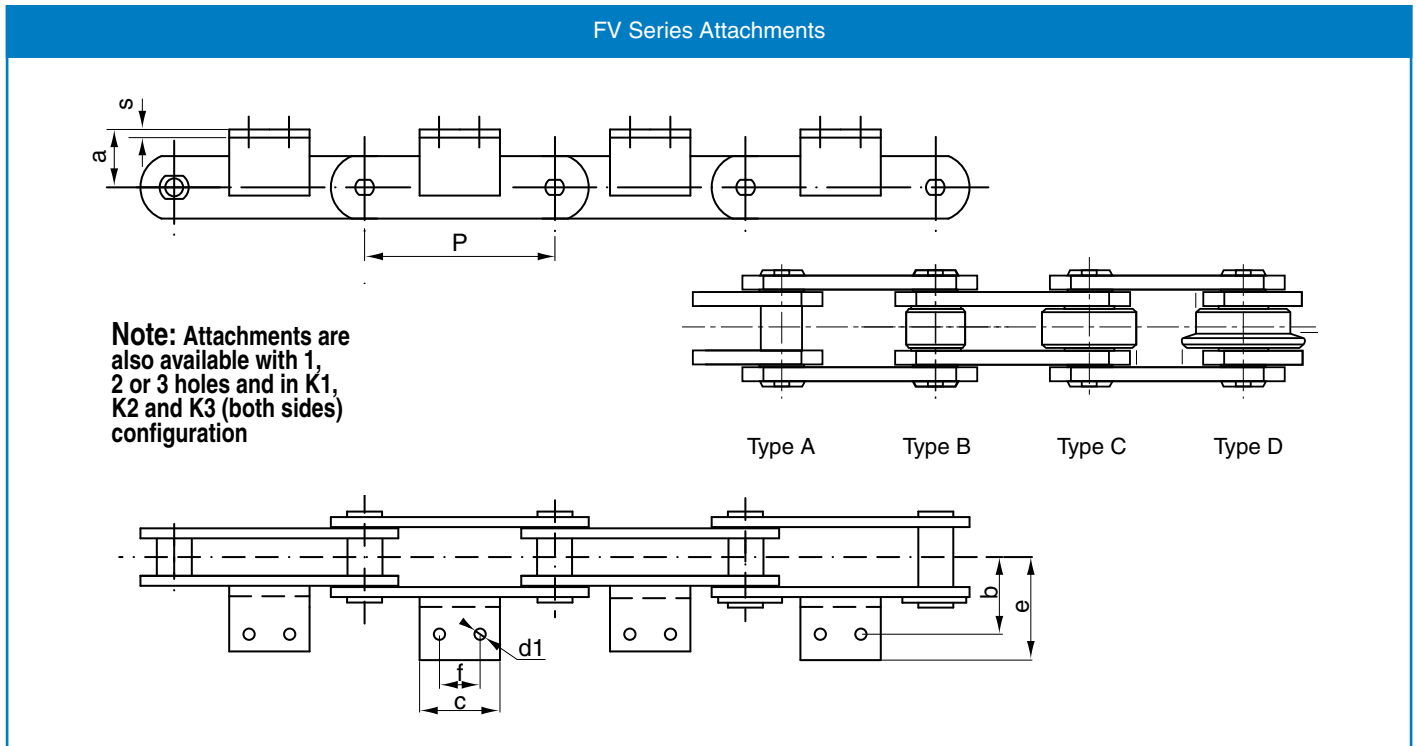

DIN Number	Chain Number	Pitch P	a	b	c	d1	e	f	Welded or Integral attachment	Chain Weight - Excluding Attachments kg/metre				Attachment Weight (A2) kg each
										Type A	Type B	Type C	Type D	
FV140	C145	100	45	50	55	11	81	30	50x6	8.2	9.5	14.3	21.4	0.23
"	"	125	"	"	65	"	"	40	"	7.4	8.5	12.3	18.0	0.30
"	"	160	"	"	75	"	"	50	"	6.7	7.5	10.5	14.9	0.36
"	"	200	"	"	90	"	"	65	"	6.0	6.7	9.0	12.8	0.45
"	"	250	"	"	105	"	"	80	"	5.8	6.3	8.3	11.0	0.54
FV180	C190	125	45	64	63	13	91	35	50x7	10.5	12.4	18.9	31.3	0.32
"	"	160	"	"	80	"	"	50	"	10.2	11.7	16.7	26.5	0.41
"	"	200	"	"	95	"	"	65	"	9.6	10.8	14.8	25.9	0.52
"	"	250	"	"	110	"	"	80	"	8.9	9.8	13.0	19.3	0.62
"	"	315	"	"	130	"	"	100	"	8.3	9.0	11.6	16.6	0.72
FV250	C275	160	55	69	80	14	106	50	60x8	13.4	16.4	23.8	45.9	0.57
"	"	200	"	"	95	"	"	65	"	12.3	14.7	20.6	38.3	0.71
"	"	250	"	"	110	"	"	80	"	11.3	13.3	17.9	32.1	0.85
"	"	315	"	"	130	"	"	100	"	10.5	12.0	15.8	27.0	1.00
"	"	400	"	"	130	"	"	100	"	9.8	10.7	13.9	23.8	1.00
FV315	C370	160	60	85	50	14	130	*	70x10	20.4	24.9	33.3	67.8	0.52
"	"	200	"	"	95	"	"	65	"	18.5	22.1	28.9	56.4	0.98
"	"	250	"	"	110	"	"	80	"	17.0	20.0	25.3	47.3	1.13
"	"	315	"	"	130	"	"	100	"	15.9	18.2	22.4	39.9	1.34
"	"	400	"	"	130	"	"	100	"	15.0	16.8	20.2	34.0	1.34

* Attachment With One Hole

Conveyor Chain

FVT/CE Series

Metric Conveyor Chain (DIN 8165)

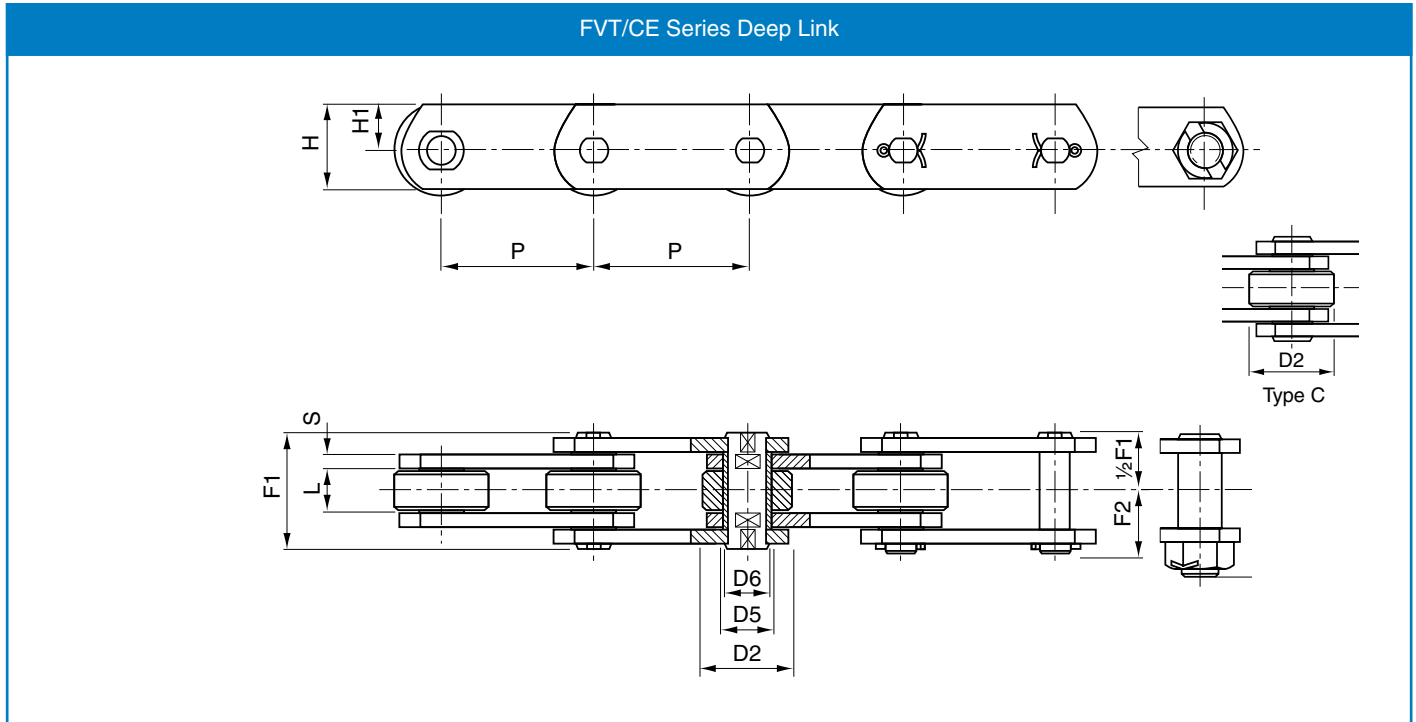

Deep Link

DIN Number	Chain number	P Pitch	L	H	H1	S	F1	F2	D2	D5	D6	Breaking Load kN	Weight kg/m
FVT40	CE42	50	18	35	22.5	3	36	21	32	15	10	42	5.0
"	"	63	"	"	"	"	"	"	"	"	"	"	4.3
"	"	80	"	"	"	"	"	"	"	"	"	"	3.8
"	"	100	"	"	"	"	"	"	"	"	"	"	3.4
"	"	125	"	"	"	"	"	"	"	"	"	"	3.0
FVT63	CE64	63	22	40	25	4	45	26	40	18	12	64	7.5
"	"	80	"	"	"	"	"	"	"	"	"	"	6.5
"	"	100	"	"	"	"	"	"	"	"	"	"	5.7
"	"	125	"	"	"	"	"	"	"	"	"	"	5.1
"	"	160	"	"	"	"	"	"	"	"	"	"	4.5
FVT90	CE100	63	25	45	27.5	5	53	30	48	20	14	100	11.7
"	"	80	"	"	"	"	"	"	"	"	"	"	10.0
"	"	100	"	"	"	"	"	"	"	"	"	"	8.7
"	"	125	"	"	"	"	"	"	"	"	"	"	7.7
"	"	160	"	"	"	"	"	"	"	"	"	"	6.8
"	"	200	"	"	"	"	"	"	"	"	"	"	5.8
"	"	250	"	"	"	"	"	"	"	"	"	"	5.4
FVT112	CE120	100	30	50	30	6	62	35	55	22	16	120	12.7
"	"	125	"	"	"	"	"	"	"	"	"	"	11.7
"	"	160	"	"	"	"	"	"	"	"	"	"	9.7
"	"	200	"	"	"	"	"	"	"	"	"	"	8.7
"	"	250	"	"	"	"	"	"	"	"	"	"	8.0

Conveyor Chain

FVT/CE Series

Metric Conveyor Chain (DIN 8165)

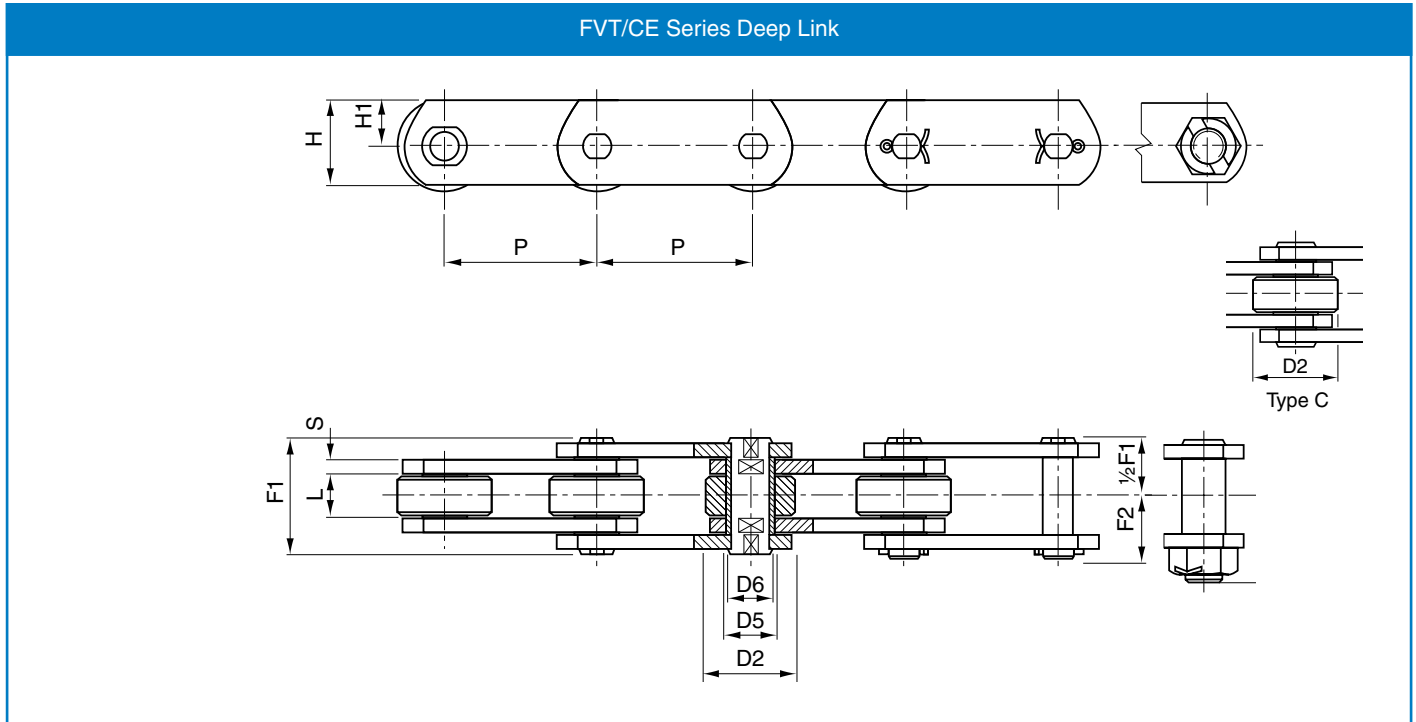

Deep Link

DIN Number	Chain Number	Pitch	L	H	H1	S	F1	F2	D2	D5	D6	Breaking Load kN	Weight kg/m
FVT140	CE145	100	35	60	37.5	6	67	38	60	26	18	145	16.8
"	"	125	"	"	"	"	"	"	"	"	"	"	14.6
"	"	160	"	"	"	"	"	"	"	"	"	"	12.6
"	"	200	"	"	"	"	"	"	"	"	"	"	11.3
"	"	250	"	"	"	"	"	"	"	"	"	"	10.1
FVT180	CE190	125	45	70	45	8	86	49	70	30	20	190	24.2
"	"	160	"	"	"	"	"	"	"	"	"	"	20.8
"	"	200	"	"	"	"	"	"	"	"	"	"	18.4
"	"	250	"	"	"	"	"	"	"	"	"	"	16.5
"	"	315	"	"	"	"	"	"	"	"	"	"	14.9
FVT250	CE275	160	55	80	50	8	97	55	80	36	26	275	28.2
"	"	200	"	"	"	"	"	"	"	"	"	"	24.5
"	"	250	"	"	"	"	"	"	"	"	"	"	21.7
"	"	315	"	"	"	"	"	"	"	"	"	"	19.3
FVT315	CE295	160	65	90	55	10	26	70	90	42	30	370	39.9
"	"	200	"	"	"	"	"	"	"	"	"	"	34.8
"	"	250	"	"	"	"	"	"	"	"	"	"	30.6
"	"	315	"	"	"	"	"	"	"	"	"	"	27.3
"	"	400	"	"	"	"	"	"	"	"	"	"	24.5

All dimensions in millimetres unless otherwise stated. Every effort has been taken to ensure that the data listed in this catalogue is correct. Challenge accepts no liability for any inaccuracies or damage caused.

Conveyor Chain

FV/CR Series

Metric Conveyor Chain (DIN 8165)

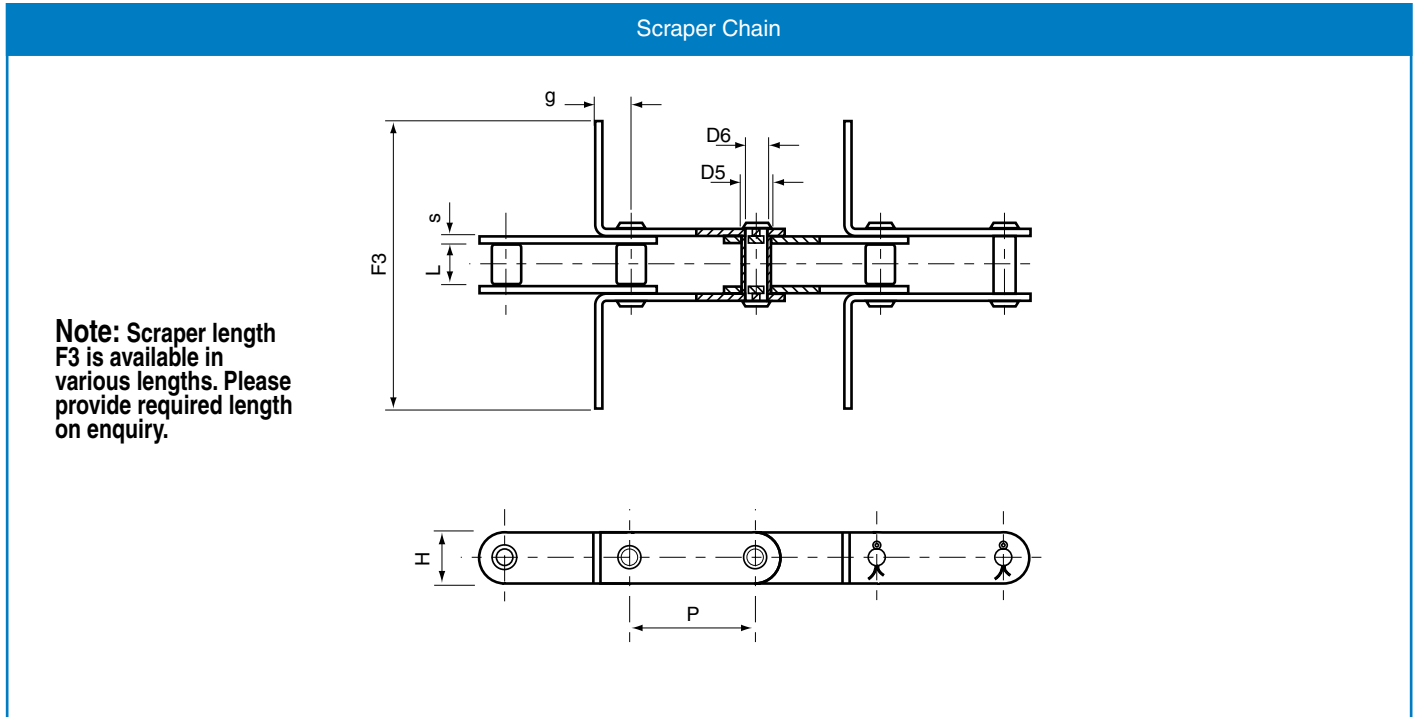

Scraper Chain

DIN Number	Chain Number	Pitch P	L	H	S	g	F3	D5	D6	Breaking Load kN	Weight kg/m
FV40	CR42	80	18	25	3	25	*	15	10	42	1.9
"	"	100	"	"	"	"	*	"	"	"	1.7
"	"	125	"	"	"	"	*	"	"	"	1.6
FV63	CR64	100	22	30	4	25	*	18	12	64	3.0
"	"	125	"	"	"	"	*	"	"	"	2.7
"	"	150	"	"	"	"	*	"	"	"	2.4
FV90	CR100	100	25	35	5	30	*	20	14	100	4.5
"	"	125	"	"	"	"	*	"	"	"	4.2
"	"	150	"	"	"	"	*	"	"	"	4.0
FV112	CR120	100	30	40	6	35	*	22	16	120	6.7
"	"	125	"	"	"	"	*	"	"	"	6.0
"	"	150	"	"	"	"	*	"	"	"	5.5
FV140	CR145	100	35	45	"	38	*	26	18	145	7.4
"	"	125	"	"	"	"	*	"	"	"	6.7
"	"	150	"	"	"	"	*	"	"	"	6.0
FV180	CR190	125	45	50	8	44	*	30	20	190	10.5
"	"	150	"	"	"	"	*	"	"	"	10.2
"	"	200	"	"	"	"	*	"	"	"	9.6
FV250	CR275	125	55	60	"	50	*	36	26	275	13.4
"	"	150	"	"	"	"	*	"	"	"	12.3
"	"	200	"	"	"	"	*	"	"	"	11.3





Conveyor Chain Attachments

Attachment Chain Designations



Attachment Chain Designations

M1-01

Attachment Orientation

- M = Vertical one side 
- MK = Vertical both sides 
- A = Horizontal one side 
- K = Horizontal both sides 

Mounting Holes

- 1 = Single Hole 
- 2 = Double 
- 3 = Triple 

Frequency

- 01 = Every side plate
- 02 = Every other side plate
- 03 = Every third side plate
- 04 = Every fourth side plate

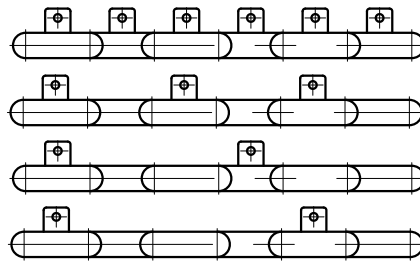

Examples

A2-02

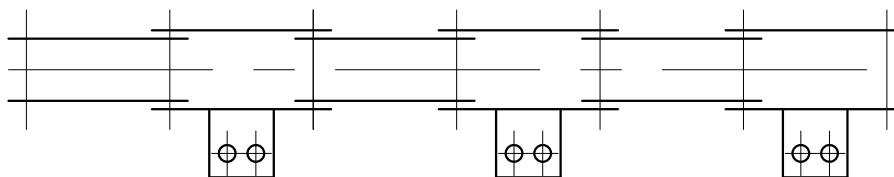

K3-01

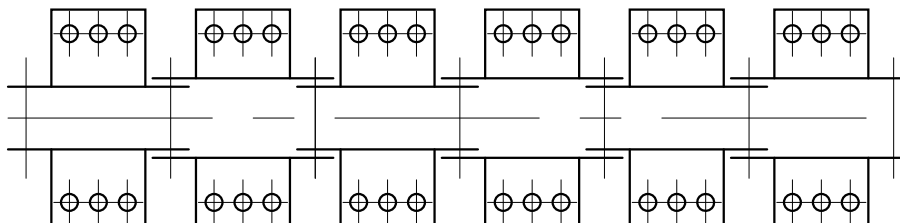

Notes
